

Precise Aircraft-to-Aircraft Positioning Using a Multiple Receiver Configuration

G. Lachapelle, H. Sun, M.E. Cannon, G. Lu

Department of Geomatics Engineering
The University of Calgary
2500 University Drive N.W.
Calgary, Alberta, T2N 1N4

ABSTRACT

A configuration of four IO-channel single frequency C/A code narrow correlator spacing receivers is used to position two aircraft with respect to each other. The platforms used are U.S. Navy P-3 Orion aircraft cruising at speeds of 300 knots. Two receivers are mounted on each aircraft, with one antenna mounted on the fuselage and the other some 20 m aft on the tail boom. On each aircraft, the double difference carrier phase ambiguities between the two receivers can be resolved in minutes using the length constraint between the two antennas. The fixed ambiguity solution accuracy is sufficient to detect length variations at the level of 1-2 cm between the two antennas due to fuselage deformation caused by temperature variations. The carrier phase ambiguities between the two aircraft navigating within a few km from each other are successfully resolved using ambiguity constraint equations provided by the quadruple receiver configuration. This yields a relative position vector accurate to the cm-level. This highly accurate solution is then used to assess the accuracy achievable with a carrier phase smoothing of the code technique operating on all four receivers. A sub-meter three-dimensional SEP accuracy is demonstrated. The effect of code multipath caused by surrounding reflecting surfaces is analysed.

INTRODUCTION

The objective of this paper is to investigate GPS techniques for the precise relative positioning of two aircraft. The aircraft type considered herein is the P-3 Orion. This aircraft, in view of its rounded fuselage, is subject to relatively high multipath, as shall be seen later. A basic assumption concerning the receiver type used for this task is that it can

track code and carrier phase on all-in-view satellites. In order to obtain strong signals and optimize tracking stability in an environment potentially subject to electromagnetic interference, single frequency C/A code tracking receivers were selected.

For the type of mission envisaged, the 5-meter tail boom is subjected to buffeting effects which can reach a few meters and it is convenient to mount the GPS antenna on it to detect this motion. In order to improve both reliability and redundancy, a second GPS antenna is mounted at a more stable location, namely on the main fuselage, some 20 m fore of the tail boom antenna, as shown in Figure 1. This results in a quadruple receiver configuration which can be used advantageously for carrier phase ambiguity resolution on the fly (OTF) between the two aircraft.

The receiver type selected for the experiments is the narrow correlator spacing NovAtel GPSCard™ which can track C/A code and carrier phase on up to 10 satellites simultaneously. The advantages of this receiver are a **10-cm** code noise and relatively low code multipath [Fenton et al 1991, Van Dierendonck et al 1992, Cannon & Lachapelle, 1992]. A Sensor Systems, Inc., antenna type, which has an aerodynamic profile suitable for aircraft use, was selected. Availability of code and carrier phase measurements allows the investigation of two techniques for relative positioning, namely carrier phase smoothing of the code, and ambiguity resolution OTF. While the carrier phase smoothing of the code method is well known [e.g., Lachapelle et al 1992a, Cannon & Lachapelle 1992], the ambiguity resolution OTF method with the constraints imposed by the quadruple antenna system is new and requires further explanation.

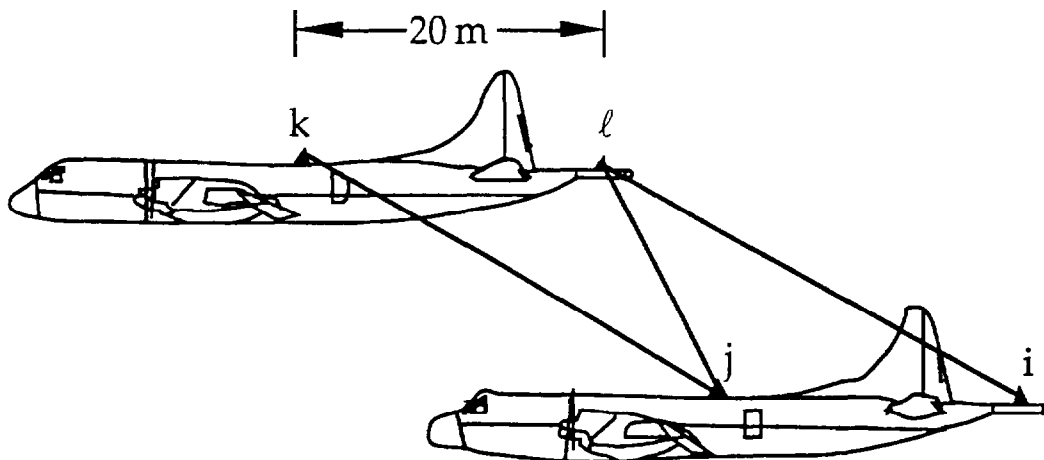

Figure 1: Aircraft-to-Aircraft GPS Positioning With Four Receivers

AMBIGUITY RESOLUTION ON THE FLY WITH A QUADRUPLE ANTENNA SYSTEM

Ambiguity resolution OTF with L1 carrier phase measurements is difficult due to the unfavorable ratio between carrier phase noise, multipath and residual orbital and atmospheric effects on the one hand, and the short (19 cm) wavelength of the carrier. Even for distances of only a few km between the two receivers, success is very much dependent on the level of carrier phase multipath as previously demonstrated [Lachapelle et al 1992b, 1993a]. The use of two pairs of receivers, as shown in Figure 1, can however improve ambiguity resolution as recently shown by Lachapelle et al [1993b] using land kinematic data. This is because the ambiguities determined by each pair of receivers must satisfy various sets of constraints.

Referring to Figure 1, the three-dimensional vector lengths $k-l$ and $i-j$ are relatively short (20 m in this case) and are known *a priori* with an accuracy of a few cm. Using the length constraints, the double difference carrier phase ambiguities $\Delta\nabla N_{k-l}$'s and $\Delta\nabla N_{i-j}$'s can be resolved reliably and rapidly, as in the case of a multi-antenna attitude system [e.g., Cannon et al 1992, Lu et al 1993, 1994]. The actual observation time required is a function of satellite geometry, vehicle dynamics and carrier phase multipath and can vary between one and several hundred epochs in extreme cases. These resolved ambiguities can then be used as another set of constraints in solving the double difference ambiguities between the two moving platforms, e.g.,

$\Delta\nabla N_{i-k}$, $\Delta\nabla N_{j-k}$, $\Delta\nabla N_{i-l}$, and $\Delta\nabla N_{j-l}$. Referring to Figure 1, the constraints can be expressed as:

$$\begin{aligned}\Delta\nabla N_{i-j} &= \Delta\nabla N_{i-k} - \Delta\nabla N_{j-k} \\ \Delta\nabla N_{i-j} &= \Delta\nabla N_{i-l} - \Delta\nabla N_{j-l} \\ \Delta\nabla N_{k-l} &= \Delta\nabla N_{k-i} - \Delta\nabla N_{l-i}\end{aligned}$$

These three sets of double difference ambiguity relations yield $(n-1) \times 3$ double difference ambiguity equations, where n is the number of satellites observed. Although the above constraint equations are not geometry independent, they still contribute to averaging out carrier phase noise and multipath. The potential ambiguities for each monitor-remote pair shown in Figure 1 are first calculated using a standard OTF procedure. Only the potential ambiguities which satisfy the above equations are retained. The distance between two antennas on the same aircraft should be sufficiently large to decorrelate carrier phase multipath. Since other considerations prevail in the installation of the antennas, this cannot always be achieved. In the present case, multipath decorrelation is likely to be reasonably achieved due to the different surrounding reflective surfaces affecting both antennas.

The four-antenna method can speed up convergence time significantly. The land kinematic test reported by Lachapelle et al [1993b] resulted in a reduction of 50% of the observation time required for convergence. In the present case, the reduction was 65% given a distance of approximately 1 km between the two aircraft.

F³LIGHTTEST

The flight test used to analyze the configuration shown in Figure 1 was conducted on July 8, 1993, on the east coast of the United States, by the Naval Air Warfare Center, Warminster. The number of available satellites varied between six and eight and the PDOP was ≤ 3 . The flight lasted five hours and the horizontal trajectories of the aircraft are shown in Figure 2. The corresponding height profiles are shown in Figure 3. The aircraft velocity, shown in Figure 4, ranged between 100 and 190 m/s with an average of 150 m/s (300 knots). Code and carrier measurements were recorded 5 times per second. During large portions of the flights, the two aircraft were within one kilometer from each other. The flight segment between 403500s and 409000s was retained to test ambiguity resolution OTF with the quadruple receiver configuration. During the 5-hour flight test, between 6 and 24 cycle slips were detected at each receiver. Many of these occurred on low elevation satellites during banking. No loss of phase lock occurred on all satellites simultaneously. The receivers mounted on the tail boom did not incur more frequent cycle slips due to the buffeting effect. Given the above, the receiver tracking performance were found to be fully satisfactory.

DATA PROCESSING AND ANALYSIS

The code and carrier phase measurements were post-processed using three software programs developed by the authors. The three-dimensional vector between two antennas on the same aircraft was resolved using MULTINAVTM [Lu et al 1993]. The carrier phase smoothing of the code solutions between the two aircraft were obtained with C³NAVTM [Cannon & Lachapelle 1992]. The carrier phase ambiguity OTF solutions between the two aircraft were obtained with FLYKINTM [Lachapelle et al 1992b] or a modification thereof. All satellites above an elevation of 10° were used in the processing.

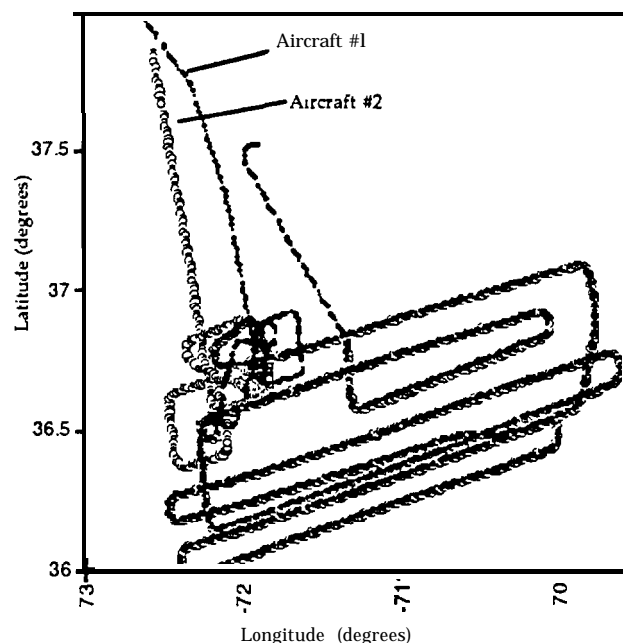

Figure 2: Trajectories of Aircraft

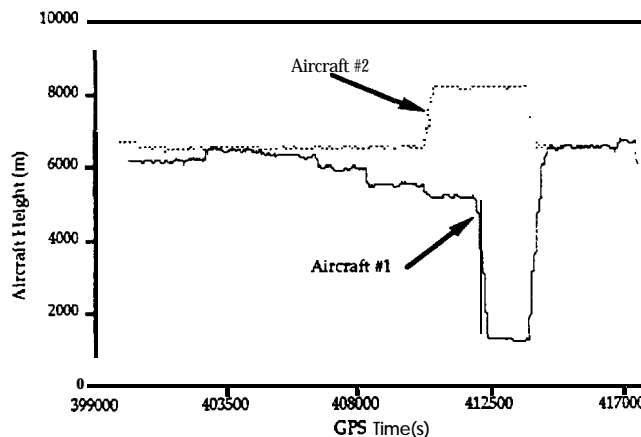

Figure 3: Height Profiles of Aircraft

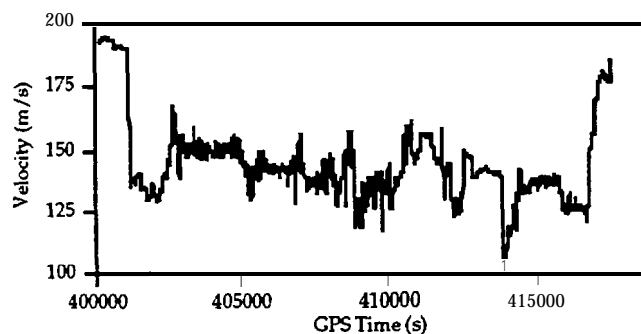

Figure 4: Velocity of Aircraft

3D Vector Solutions: Two Antennas on one Aircraft

The integer ambiguities of the three-dimensional vector between two antennas on the same aircraft were resolved numerous times using up to a few minutes of data. As mentioned earlier, the known distance was initially used as a loose (\pm few cm) constraint to fix the ambiguities. The effectiveness of the procedure is illustrated in Figure 5 which shows the differences between the computed (with resolved integer ambiguities) and known distance between the two antennas on Aircraft #1 as a function of time. After an initial period, the differences are generally contained within an envelope of 1 cm, except for an interval of about 20 minutes around 413000 s during which the differences exceed 2 cm. During this interval, however, the aircraft went down from about 5,000 m to 1,000 m, as can be seen in Figure 3. The corresponding temperature increase, assuming a normal environmental lapse rate of 65°C per 1,000 m, is therefore 26°C. This corresponds to an expansion of the distance between the two antennas of about 1.5 cm, as measured by GPS. Likewise, the distance variations at the beginning of the mission are possibly due to initial instabilities in the aircraft aluminum frame. This illustrates the capability of GPS for in-flight fuselage and wing flexing analysis.

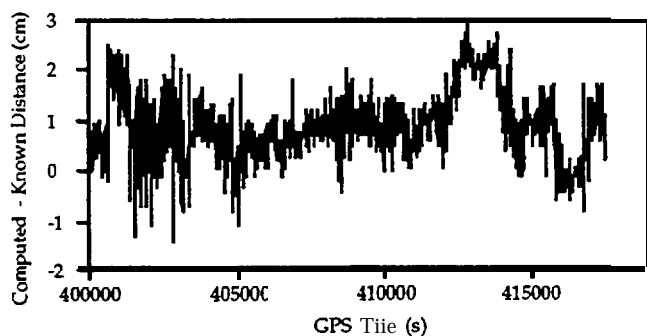

Figure 5: Computed Minus Known Distance Between the two Antennas - Aircraft #1

Carrier phase multipath between the two antennas can be illustrated by showing the double difference carrier phase residuals obtained from the least-squares adjustment of the measurements with the integer ambiguities resolved. Since six to eight satellites were available, redundant observations were available and the residuals are meaningful. Representative residuals are shown in Figure 6. The rms residuals are 0.55 and 0.46 cm. This corresponds

to average multipath conditions, as compared to the land or shipborne case.

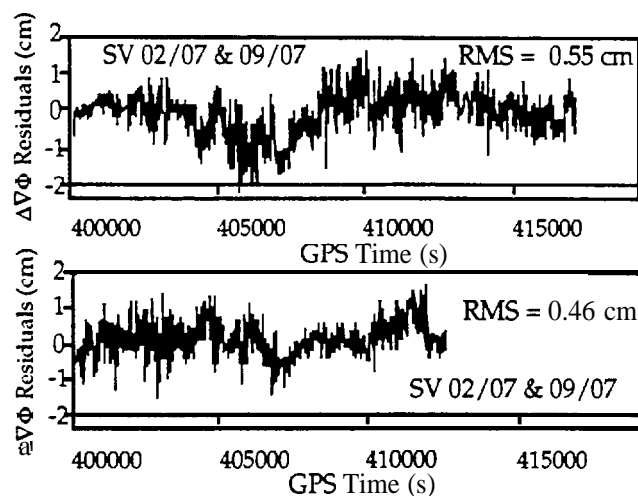

Figure 6: Double Difference Carrier Phase Residuals - Solution Between the two Antennas (Aircraft #1)

Ambiguity Resolution OTF between Aircraft

During the period 403500s to 409000s, the two aircraft were within one km and the constraints provided by the quadruple receiver configuration were used to eliminate pairs of ambiguities which did not satisfy the equations. Some 38 trials, each shifted in time by 90 seconds, were conducted. A unique solution was obtained after four to six minutes of measurements. During that period, it is assumed that no irrecoverable cycle slips occur. Some 50% of the solutions yielded the same ambiguities while the other solutions gave different solutions. This is a fairly reliable indication that these ambiguities are the correct ones. Another indication is the trend in the double difference carrier phase residuals. If incorrect ambiguities are retained, these will drift over time. Sample residuals for the antenna pair located on the fuselage (fore) of the two aircraft are shown in Figure 7 for the entire period of 90 minutes. No long term trends are occurring. The short term biases are due to a combination of multipath and residual atmospheric effects. The RMS values, which are of the order of 0.80 cm, are larger than the corresponding values shown in Figure 6 for the two antenna on one aircraft case. The difference between the two sets of RMS values is due to residual atmospheric effects **between** the two aircraft.

When the distance between the two aircraft is larger than a few km, the integer ambiguities can no longer

be resolved due to the reasons described earlier. Integer ambiguity resolution with L1 only carrier phase observations is therefore limited to relatively short distances between the aircraft. The technique is however useful for various applications, a description of which is beyond the scope of this paper. One application which is however relevant to this paper is that ambiguity resolution provides reference trajectories for the aircraft which are accurate at the cm-level in the relative sense. These reference trajectories can then be used to assess the level of accuracy achievable with the more robust but less accurate carrier phase smoothing of the code method.

Carrier Phase Smoothing Solutions between Aircraft

The carrier phase smoothing of the code technique used in C³NAV™ consists of parallel filters which are reset at operator selected intervals to maximize accuracy performance while minimizing code multipath effects [Lachapelle et al 1992a; Cannon & Lachapelle 1992]. The accuracy of the method, when using GPSCard™ sensors, varies between a few decimeters to over one meter, in terms of rms differences in each of the three coordinates, depending on multipath conditions.

In the present case, carrier phase smoothing of the code solutions were calculated using two antennas on different aircraft. The coordinate differences obtained were compared with those obtained with the ambiguity resolution OTF solutions. Results for one pair of receivers are shown in Figure 8. The RMS differences in latitude, longitude and height are 0.38 m, 0.73 m, and 1.22 m, respectively. This corresponds to a Spherical Error Probable of 1.17 m. Since this corresponds to one pair of receivers, the average of the two pairs of receivers will yield a better accuracy, namely $1.17\text{m}/\sqrt{2}$ or 0.83 m SEP. That the level of accuracy is dependent on multipath and, therefore, on the aircraft type and the location of the antenna is evidenced by an accuracy of 0.40m SEP obtained by Tiemeyer et al [1994] using a single pair of GPSCard™ receivers (ground /aircraft). The aircraft type was a Domier DO128 which has a more angular fuselage less prone to signal reflection.

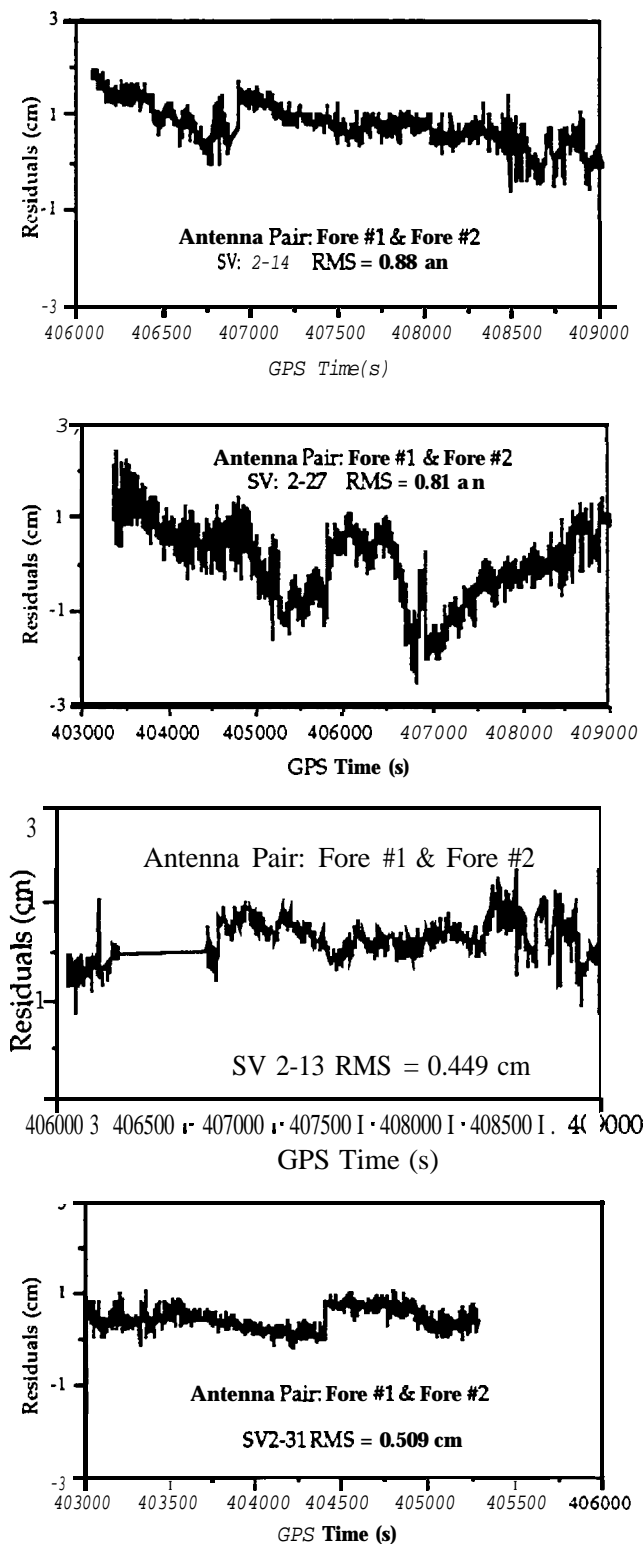

Figure 7: Double Difference Carrier Phase Residuals - Solution Between the two Aircraft (#1 and #2)

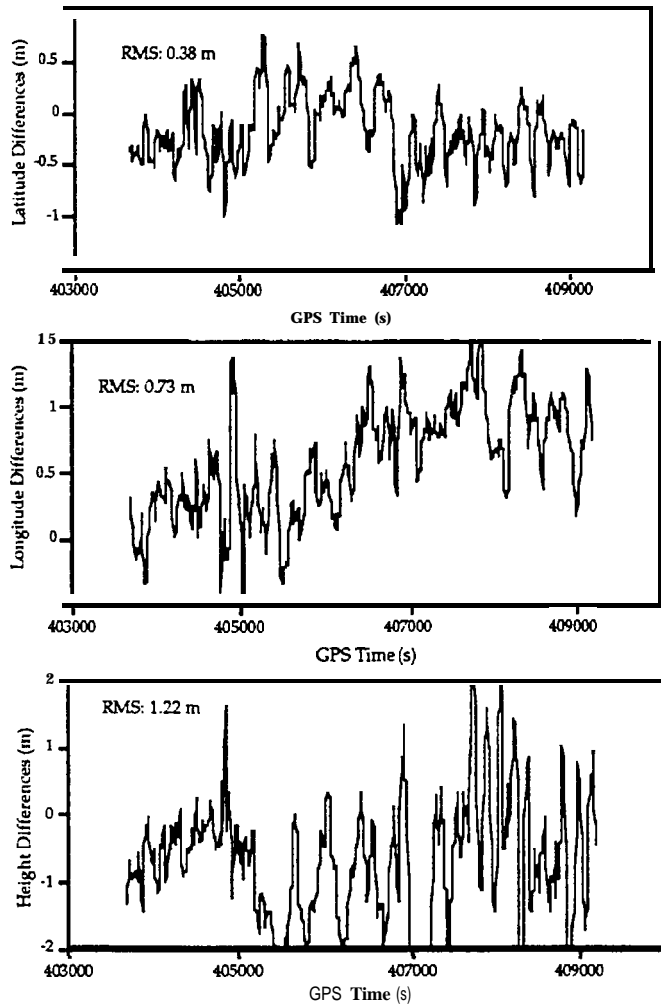

Figure 8: Differences between Resolved Ambiguity and Carrier Phase Smoothing of the Code (1 Pair of Receivers) Solutions

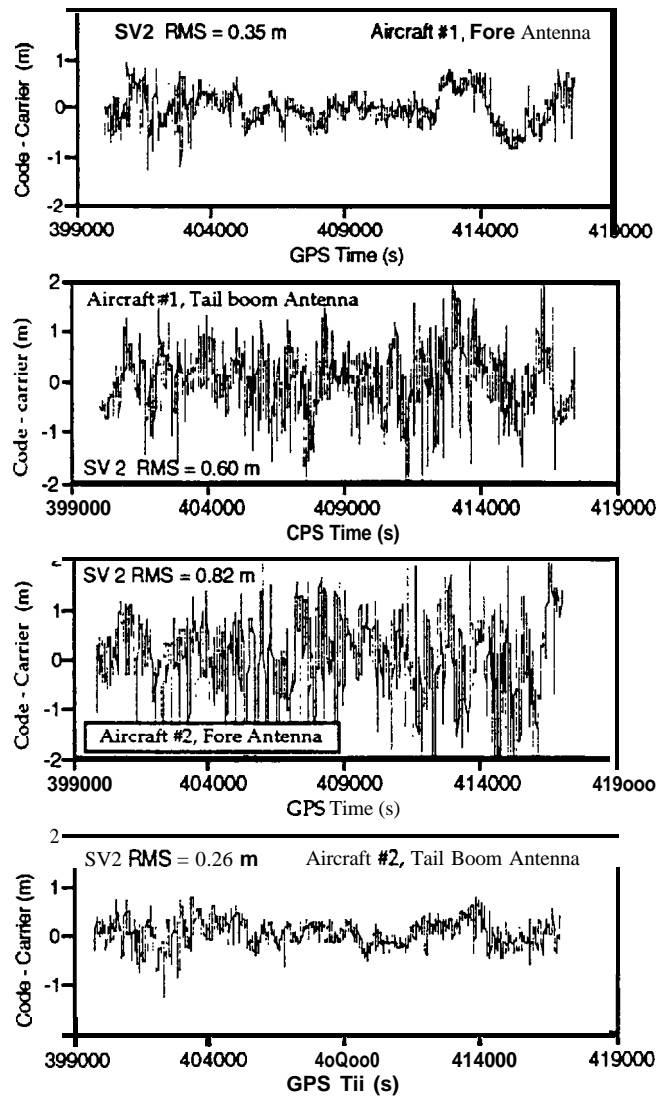

Figure 9: Code Multipath (Code - Carrier Phase) on Aircraft

The level of code multipath which was occurring on the aircraft during the flight test is illustrated in Figure 9. The differences between code and carrier phase on SV2 at each one of the four antennas are shown. Since the combined effect of carrier phase noise and multipath is of the order of a few centimeters, most of the residual effects shown are caused by the combined effect of code noise and multipath. The RMS effect varies between 0.26 and 0.82 cm. The latter value is relatively high and is due to the highly reflective surfaces of the P-3 Orion aircraft.

CONCLUSIONS

The flight test results presented here show that the use of a configuration of four single frequency narrow correlator spacing receivers can deliver a relative accuracy superior to 1 m SEP for aircraft to aircraft positioning using a robust carrier smoothing of the code approach. The results shown here are for a distance of one kilometer between the aircraft. As this distance increases, the accuracy will degrade slightly, and the 83 cm SEP obtained here is expected to degrade to 1 m SEP for distances of 30 km or greater, depending on differential atmospheric conditions.

The ambiguity resolution OTF method used is effective to obtain aircraft reference trajectories which are relatively accurate to the cm-level. In addition to being useful for some applications, these reference trajectories can be used to assess the accuracy of less accurate but more robust methods.

Acknowledgements

This research was sponsored by the Naval Air Warfare Center, Department of the Navy, Warminster, PA.

REFERENCES

- CANNON, M.E., and G. LACHAPELLE [1992] Analysis of a High Performance C/A Code GPS Receiver in Kinematic Mode. *Navigation*, The Institute of Navigation, Alexandria, VA, 39, 3, 285-299.
- CANNON, M.E., J.B. SCHLEPPE, J.F. MCLELLAN and T.E. OLLEVIER [1992], Real-Time Heading Determination Using an Integrated GPS-Dead Reckoning System, *Proceedings of ION GPS-92*, Institute of Navigation, 767-773.
- FENTON, P., FALKENBERG, W., FORD, T., NG, K., and VAN DIERENDONCK, A. J., *NovAtel's GPS Receiver, the High Performance OEM Sensor of the Future*. *Proceedings of GPS'91*, The Institute of Navigation, pp. 49-58.
- LACHAPELLE, G., M.E. CANNON, and G. LU [1992a] High Precision GPS Navigation With Emphasis on Carrier Phase Ambiguity Resolution. *Marine Geodesy*, 15,4,253-269.
- LACHAPELLE, G., M.E. CANNON, and G. LU [1992b] Ambiguity Resolution On The Fly - A Comparison of P Code and High Performance C/A Code Receiver Technologies. *Proceedings of ION GPS-92*, The Institute of Navigation, Alexandria, VA, 1025-1032.
- LACHAPELLE, G., C. LIU, G. LU, B. TOWNSEND, M.E. CANNON, and R. HARE [1993a] Precise Marine DGPS Positioning Using P Code and High Performance C/A Code Technologies. *Proceedings of National Technical Meeting*, The Institute of Navigation, Alexandria, VA, 241-250.
- LACHAPELLE, G., C. LIU, and G. LU [1993b] Quadruple Single Frequency Receiver System for Ambiguity Resolution on the Fly. *Proceedings of ION GPS93*, Salt Lake City, 22-24 September (in press).
- LU, G., M.E. CANNON, G. LACHAPELLE, and P. KIELLAND [1993] Attitude Determination in a Survey Launch Using Multi-Antenna GPS Technologies. *Proceedings of National Technical Meeting*, The Institute of Navigation, Alexandria, VA, 251-260.
- LU, G., G. LACHAPELLE, M.E. CANNON, and B. VOGEL [1994] Performance Analysis of a Shipborne Gyrocompass with a Multi-Antenna GPS System. *Proceedings of IEEE PLANS'94*, Las Vegas (11-15 April), in press.
- TIEMEYER, B., M.E. CANNON, G. LU, and G. SCHÄNZER [1994] Ambiguity Resolution of GPS L1 Carrier Wave Measurements for High Precision Aircraft Navigation. Presented at National Technical Meeting, The Institute of Navigation, San Diego, CA, 24-26 January.
- VAN DIERENDONCK, A.J., P. FENTON, and T. FORD [1992] Theory and Performance of Narrow Correlator Spacing in a GPS Receiver. *Navigation*, Institute of Navigation, Alexandria, VA, 39, 3, 265-283.