

OEM4 Family

USER MANUAL - VOLUME 2
Command and Log Reference

OEM4 Family of Receivers - Command and Log Reference Manual

Publication Number: OM-20000047
Revision Level: 18
Revision Date: 2005/10/27

This manual reflects firmware version 2.310.

Proprietary Notice

Information in this document is subject to change without notice and does not represent a commitment on the part of NovAtel Inc. The software described in this document is furnished under a licence agreement or non-disclosure agreement. The software may be used or copied only in accordance with the terms of the agreement. It is against the law to copy the software on any medium except as specifically allowed in the license or non-disclosure agreement.

No part of this manual may be reproduced or transmitted in any form or by any means, electronic or mechanical, including photocopying and recording, for any purpose without the express written permission of a duly authorized representative of NovAtel Inc.

The information contained within this manual is believed to be true and correct at the time of publication.

NovAtel, GPSolution, MiLLennium, ProPak, RT-20 and RT-2 are registered trademarks of NovAtel Inc.

PAC, GPSCard, and GPSAntenna are trademarks of NovAtel Inc.

All other brand names are trademarks of their respective holders.

© Copyright 2000-2005 NovAtel Inc. All rights reserved.

Unpublished rights reserved under International copyright laws.

Printed in Canada on recycled paper. Recyclable.



Table of Contents

Proprietary Notice	2
Foreword	11
Scope	11
User Manual Updates	11
Prerequisites	11
Conventions	11
What's New in Firmware Version 2.310 Since Version 2.300.....	12
1 Messages	13
1.1 Message Types.....	13
1.1.1 ASCII	14
1.1.2 Abbreviated ASCII	16
1.1.3 Binary	16
1.2 Responses	20
1.3 GPS Time Status	21
1.4 Message Time Stamps	23
1.5 Decoding of the GPS Week Number	23
1.6 32-Bit CRC.....	24
2 Commands	26
2.1 Command Formats	26
2.2 Command Settings	26
2.3 Commands by Function	27
2.4 MiLLennium GPSCard Compatibility	39
2.5 Factory Defaults.....	40
2.6 Command Reference.....	42
2.6.1 ADJUST1PPS Adjust the receiver clock.....	42
2.6.2 ANTENNAPOWER Control power to the antenna.....	46
2.6.3 ASSIGN Assign a channel to a PRN	47
2.6.4 ASSIGNALL Assign all channels to a PRN.....	49
2.6.5 ASSIGNLBAND Set L-band satellite communication parameters	51
2.6.6 AUTH Add authorization code for new model.....	53
2.6.7 CLOCKADJUST Enable clock adjustments.....	55
2.6.8 CLOCKCALIBRATE Adjust clock steering parameters	56
2.6.9 CLOCKOFFSET Adjust for delay in 1PPS output.....	58
2.6.10 COM COM port configuration control.....	59
2.6.11 COMCONTROL Control the RS232 hardware control lines	61
2.6.12 CSMOOTH Set carrier smoothing	63
2.6.13 DATUM Choose a datum name type	64
2.6.14 DGPSEPHEMDELAY DGPS ephemeris delay DGPS.....	68
2.6.15 DGPSRXID.....	69
2.6.16 DGPSTIMEOUT Set maximum age of differential data DGPS	70
2.6.17 DGPSTXID DGPS transmit ID DGPS	71
2.6.18 DYNAMICS Tune receiver parameters.....	72
2.6.19 ECUTOFF Set satellite elevation cut-off	73
2.6.20 EXTERNALCLOCK Set external clock parameters	74
2.6.21 FIX Constrain to fixed height or position	77

2.6.22	FIXPOSDATUM	Set position through a specified datum	80
2.6.23	FREQUENCYOUT	Set output pulse train available on VARF	81
2.6.24	FRESET	Clear selected data from NVM and reset	83
2.6.25	GGAQUALITY	Customize the GP GGA GPS quality indicator	84
2.6.26	HPSEED	Specify the OmniSTAR HP seed position	85
2.6.27	HPSTATICINIT	Set OmniSTAR HP static initialization	86
2.6.28	INTERFACEMODE	Set receive or transmit modes for ports DGPS ...	87
2.6.29	LOCKOUT	Prevent the receiver from using a satellite	89
2.6.30	LOG	Request logs from the receiver	90
2.6.31	MAGVAR	Set a magnetic variation correction	93
2.6.32	MARKCONTROL	Control processing of mark inputs	95
2.6.33	MODEL	Switch to a previously authorized model	97
2.6.34	MOVINGBASESTATION	Set ability to use a moving base station	98
2.6.35	NVMRESTORE	Restore NVM data after an NVM failure	99
2.6.36	PASSTOPASSMODE	Enable/disable solution smoothing modes	100
2.6.37	POSAVE	Implement base station position averaging	101
2.6.38	POSTIMEOUT	Sets the position time out	102
2.6.39	PPSCONTROL	Control the PPS output.....	103
2.6.40	PSRDIFFSOURCE	Set the pseudorange correction source DGPS..	104
2.6.41	RESET	Perform a hardware reset.....	106
2.6.42	RTKBASLINE	Initialize RTK with a static baseline RTK	107
2.6.43	RTKCOMMAND	Reset or set the RTK filter to its defaults RTK.....	109
2.6.44	RTKDYNAMICS	Set the RTK dynamics mode RTK.....	110
2.6.45	RTKELEV MASK	Set the RTK mask angle RTK.....	111
2.6.46	RTKSOLUTION	Set RTK carrier phase ambiguity type RTK	112
2.6.47	RTKSOURCE	Set the RTK correction source RTK.....	113
2.6.48	RTKSVENTRIES	Set number of satellites in corrections RTK.....	114
2.6.49	SAVECONFIG	Save current configuration in NVM	115
2.6.50	SBASCONTROL	Set SBAS test mode and PRN SBAS.....	116
2.6.51	SEND	Send an ASCII message to a COM port	118
2.6.52	SENDHEX	Send non-printable characters in hex pairs	120
2.6.53	SETAPPROXPOS	Set an approximate position	121
2.6.54	SETAPPROXTIME	Set an approximate GPS time	122
2.6.55	SETNAV	Set start and destination waypoints	123
2.6.56	SETRTCM16	Enter ASCII text for RTCM data stream DGPS/RTK...	125
2.6.57	STATUSCONFIG	Configure RXSTATUS EVENT mask fields	126
2.6.58	UNASSIGN	Unassign a previously assigned channel	127
2.6.59	UNASSIGNALL	Unassign all previously assigned channels.....	127
2.6.60	UNDULATION	Choose undulation	128
2.6.61	UNLOCKOUT	Reinstate a satellite in the solution	130
2.6.62	UNLOCKOUTALL	Reinstate all previously locked out satellites	130
2.6.63	UNLOG	Remove a log from logging control.....	131
2.6.64	UNLOGALL	Remove all logs from logging control	132
2.6.65	USERDATUM	Set user-customized datum	133
2.6.66	USEREXP DATUM	Set custom expanded datum.....	134
2.6.67	UTMZONE	Set UTM parameters	135
2.6.68	WAASCORRECTION	SBAS.....	137

2.6.69 WAASECUTOFF	Set SBAS satellite elevation cut-off.....	138
3 Data Logs		139
3.1	Log Types	139
3.2	Logs By Function	139
3.3	MiLLennium GPSCard Compatibility	156
3.4	Log Reference	156
3.4.1	ALMANAC Decoded Almanac	157
3.4.2	AVEPOS Position Averaging	159
3.4.3	BESTPOS Best Position.....	161
3.4.4	BESTUTM Best Available UTM Data.....	164
3.4.5	BESTVEL Best Available Velocity Data.....	166
3.4.6	BESTXYZ Best Available Cartesian Position and Velocity	168
3.4.7	BSLNXYZ RTK XYZ Baseline RTK.....	171
3.4.8	CLOCKMODEL Current Clock Model Status.....	173
3.4.9	CLOCKSTEERING Clock Steering Status.....	175
3.4.10	CMR Standard Logs RTK	177
3.4.11	CMRDATADESC Base Station Description RTK.....	178
3.4.12	CMRDATAOBS Base Station Satellite Observations RTK	180
3.4.13	CMRDATAREF Base Station Position RTK.....	182
3.4.14	CMRPLUS CMR+ Output Message RTK.....	184
3.4.15	COMCONFIG Current COM Port Configuration	185
3.4.16	GPALM Almanac Data NMEA.....	186
3.4.17	GPGGA GPS Fix Data and Undulation NMEA.....	188
3.4.18	GPGGALONG Fix Data, Extra Precision and Undulation NMEA.....	190
3.4.19	GPGGARTK Global Position System Fix Data NMEA	192
3.4.20	GPGLL Geographic Position NMEA.....	194
3.4.21	GPGRS GPS Range Residuals for Each Satellite NMEA.....	195
3.4.22	GPGSA GPS DOP and Active Satellites NMEA	196
3.4.23	GPGST Pseudorange Measurement Noise Statistics NMEA	197
3.4.24	GPGSV GPS Satellites in View NMEA	198
3.4.25	GPRMB Navigation Information NMEA.....	199
3.4.26	GPRMC GPS Specific Information NMEA	200
3.4.27	GPSEPHM Decoded GPS Ephemerides	201
3.4.28	GPVTG Track Made Good And Ground Speed NMEA.....	204
3.4.29	GPZDA UTC Time and Date NMEA.....	205
3.4.30	IONUTC Ionospheric and UTC Data.....	206
3.4.31	LBANDINFO L-Band Configuration Information	207
3.4.32	LBANDSTAT L-Band Status Information	209
3.4.33	LOGLIST List of System Logs	212
3.4.34	MARKPOS, MARK2POS Position at Time of Mark Input Event	214
3.4.35	MARKTIME, MARK2TIME Time of Mark Input Event.....	216
3.4.36	MATCHEDPOS Matched RTK Position RTK.....	217
3.4.37	MATCHEDXYZ Matched RTK Cartesian Position RTK	219
3.4.38	NAVIGATE User Navigation Data.....	221
3.4.39	NMEA Standard Logs.....	223
3.4.40	OMNIHPPOS OmniSTAR HP Position	224
3.4.41	PASSCOM, PASSXCOM, PASSAUX, PASSUSB Redirect Data.....	226
3.4.42	PORTSTATS Port Statistics	228
3.4.43	PSRDOP Pseudorange DOP.....	230

3.4.44 PSRPOS Pseudorange Position	231
3.4.45 PSRVEL Pseudorange Velocity	232
3.4.46 PSRXYZ Pseudorange Cartesian Position and Velocity	234
3.4.47 RANGE Satellite Range Information	236
3.4.48 RANGECMP Compressed Version of the RANGE Log	240
3.4.49 RANGEGPSL1 L1 Version of the RANGE Log	242
3.4.50 RAWALM Raw Almanac Data	243
3.4.51 RAWEPHEM Raw Ephemeris	244
3.4.52 RAWGPSSUBFRAME Raw Subframe Data	245
3.4.53 RAWGPSWORD Raw Navigation Word	246
3.4.54 RAWLBANDFRAME Raw L-Band Frame Data	247
3.4.55 RAWLBANDPACKET Raw L-Band Data Packet	248
3.4.56 RAWWAASFRAME Raw SBAS Frame Data SBAS	249
3.4.57 REFSTATION Base Station Position and Health RTK	250
3.4.58 RTCA Standard Logs DGPS	252
3.4.59 RTCADATA1 Differential GPS Corrections DGPS	253
3.4.60 RTCADATAEPHEM Ephemeris and Time Information DGPS & RTK	254
3.4.61 RTCADATAOBS Base Station Observations RTK	255
3.4.62 RTCADATAREF Base Station Parameters RTK	257
3.4.63 RTCM Standard Logs DGPS	258
3.4.64 RTCMDATA1 Differential GPS Corrections DGPS	260
3.4.65 RTCMDATA3 Base Station Parameters RTK	261
3.4.66 RTCMDATA9 Partial Differential GPS Corrections DGPS	262
3.4.67 RTCMDATA15 Ionospheric Corrections DGPS	263
3.4.68 RTCMDATA16 Special Message DGPS & RTK	264
3.4.69 RTCMDATA1819 Raw Measurements RTK	265
3.4.70 RTCMDATA2021 Measurement Corrections RTK	269
3.4.71 RTCMDATA22 Extended Base Station RTK	273
3.4.72 RTCMDATA59 Type 59N-0 NovAtel RT20 Differential RTK	274
3.4.73 RTCMV3 RTCMV3 Standard Logs RTK	276
3.4.74 RTCMDATA1001 L1-Only GPS RTK Observables RTK	277
3.4.75 RTCMDATA1002 Extended L1-Only GPS RTK Observables RTK ...	280
3.4.76 RTCMDATA1003 L1/L2 GPS RTK Observables RTK	282
3.4.77 RTCMDATA1004 Expanded L1/L2 GPS RTK Observables RTK	284
3.4.78 RTCMDATA1005 Base Station Antenna Reference Point (ARP) RTK	286
3.4.79 RTCMDATA1006 Base Station ARP with Antenna Height RTK	287
3.4.80 RTKDATA RTK Solution Parameters RTK	288
3.4.81 RTKPOS RTK Low Latency Position Data RTK	291
3.4.82 RTKVEL RTK Velocity RTK	293
3.4.83 RTKXYZ RTK Cartesian Position and Velocity RTK	295
3.4.84 RXCONFIG Receiver Configuration	297
3.4.85 RXHWLEVELS Receiver Hardware Levels	299
3.4.86 RXSTATUS Receiver Status	300
3.4.87 RXSTATUSEVENT Status Event Indicator	305
3.4.88 SATVIS Satellite Visibility	307
3.4.89 SATXYZ SV Position in ECEF Cartesian Coordinates	308
3.4.90 TIME Time Data	309
3.4.91 TIMESYNC Synchronize Time Between GPS Receivers	310
3.4.92 TRACKSTAT Tracking Status	311

3.4.93 VALIDMODELS Valid Model Information	313
3.4.94 VERSION Version Information.....	314
3.4.95 WAAS0 Remove PRN from Solution SBAS.....	317
3.4.96 WAAS1 PRN Mask Assignments SBAS	318
3.4.97 WAAS2 Fast Correction Slots 0-12 SBAS	319
3.4.98 WAAS3 Fast Corrections Slots 13-25 SBAS.....	321
3.4.99 WAAS4 Fast Correction Slots 26-38 SBAS	323
3.4.100 WAAS5 Fast Correction Slots 39-50 SBAS	325
3.4.101 WAAS6 Integrity Message SBAS.....	327
3.4.102 WAAS7 Fast Correction Degradation SBAS.....	329
3.4.103 WAAS9 GEO Navigation Message SBAS.....	331
3.4.104 WAAS10 Degradation Factor SBAS	332
3.4.105 WAAS12 SBAS Network Time and UTC SBAS.....	333
3.4.106 WAAS17 GEO Almanac Message SBAS.....	334
3.4.107 WAAS18 IGP Mask SBAS	335
3.4.108 WAAS24 Mixed Fast/Slow Corrections SBAS	336
3.4.109 WAAS25 Long-Term Slow Satellite Corrections SBAS.....	338
3.4.110 WAAS26 Ionospheric Delay Corrections SBAS.....	340
3.4.111 WAAS27 SBAS Service Message SBAS.....	341
3.4.112 WAAS32 CDGPS Fast Correction Slots 0-10 CDGPS	342
3.4.113 WAAS33 CDGPS Fast Correction Slots 11-21 CDGPS	344
3.4.114 WAAS34 CDGPS Fast Correction Slots 22-32 CDGPS	345
3.4.115 WAAS35 CDGPS Fast Correction Slots 33-43 CDGPS	346
3.4.116 WAAS45 CDGPS Slow Corrections CDGPS.....	347
3.4.117 WAASCORR SBAS Range Corrections Used SBAS.....	348
4 Responses	349

Figures

1	1PPS Alignment	42
2	Pulse Width and 1PPS Coherency	82
3	Illustration of Magnetic Variation & Correction	94
4	TTL Pulse Polarity	96
5	Using the SEND Command	119
6	Illustration of SETNAV Parameters	124
7	Illustration of Undulation	129
8	The WGS84 ECEF Coordinate System	170
9	Navigation Parameters	221

Tables

1	Field Types	13
2	Byte Arrangements	14
3	ASCII Message Header Structure	15
4	Binary Message Header Structure	17
5	Detailed Serial Port Identifiers	18
6	Binary Message Sequence	21
7	GPS Time Status	21
8	Commands By Function Table	27
9	OEM4 Family Commands in Alphabetical Order	31
10	OEM4 Family Commands in Order of their Message IDs	35
11	OEM4 Family Command Comparison	39
12	Channel State	47
13	Channel System	50
14	L-Band Mode	52
15	COM Serial Port Identifiers	60
16	Parity	60
17	Handshaking	60
18	Tx and DTR Availability	62
19	Reference Ellipsoid Constants	65
20	Datum Transformation Parameters	65
21	User Dynamics	72
22	Clock Type	76
23	Pre-Defined Values for Oscillators	76
24	FIX Parameters	78
25	Fix Types	78
26	FRESET Target	83
27	Seeding Mode	85
28	Serial Port Interface Modes	88
29	LOG Command Binary Format	90
30	LOG Command ASCII Format	92
31	DGPS Type	105
32	Baseline Parameters	107
33	Baseline Type	108
34	Dynamics Mode	110
35	Type of Carrier Phase Ambiguity	112
36	System Types	117
37	Mask Types	126
38	UNLOG Command ASCII Format	131
39	UNLOG Command Binary Format	131
40	UTM Zone Commands	136
41	Log Type Triggers	139
42	Logs By Function Table	140
43	OEM4 Family Logs in Alphabetical Order	146
44	OEM4 Family Logs in Order of their Message IDs	151

45	MiLlennium OEM3 Log Comparison	156
46	Position Averaging Status	160
47	Position or Velocity Type	162
48	Solution Status	163
49	Clock Model Status.....	173
50	Clock Source	176
51	Steering State.....	176
52	Position Accuracy	183
53	Position Precision of NMEA Logs.....	194
54	URA Variance.....	202
55	L-Band Subscription Type	208
56	L-Band Signal Tracking Status	210
57	OmniSTAR VBS Status Word	210
58	OmniSTAR HP Additional Status Word.....	211
59	OmniSTAR HP Status Word.....	211
60	LOGLIST ASCII Format.....	213
61	Navigation Data Type	221
62	Channel Tracking Status	237
63	Channel Tracking Example	239
64	Tracking State	239
65	Correlator Spacing.....	239
66	Range Record Format (RANGECMP only)	241
67	Base Station Status	251
68	Base Station Type	251
69	RTCM1819 Data Quality Indicator.....	267
70	RTCM1819 Smoothing Interval	268
71	RTCM1819 Multipath Indicator.....	268
72	RTCM2021 Data Quality Indicator.....	272
73	RTCM2021 Multipath Indicator.....	272
74	Carrier Smoothing Interval of Code Phase.....	278
75	Lock Time Indicator	278
76	Searcher Type	290
77	Ambiguity Type.....	290
78	RTK Information	290
79	Receiver Hardware Parameters	299
80	Receiver Error	302
81	Receiver Status	303
82	Auxiliary 1 Status.....	304
83	Auxiliary 2 Status.....	304
84	Auxiliary 3 Status.....	304
85	Status Word.....	306
86	Event Type	306
87	Range Reject Code	312
88	Component Types	315
89	VERSION Log: Field Formats	316
90	Evaluation of UDREI.....	320
91	Evaluation of CDGPS UDREI.....	343
92	Response Messages.....	349

Foreword

Whether you have bought a stand alone GPSCard or a packaged receiver you will have also received companion documents to this manual. They will help you get the hardware operational. Afterwards, this text will be your primary OEM4 family command and logging reference.

Scope

This manual describes each command and log that the OEM4 family of receivers are capable of accepting or generating. Sufficient detail is provided so that you should understand the purpose, syntax, and structure of each command or log and be able to effectively communicate with the receiver, thus enabling you to effectively use and write custom interfacing software for specific needs and applications. The manual is organized into chapters which allow easy access to appropriate information about the receiver.

There is also Satellite Based Augmentation System (SBAS) signal functionality. Please refer to the *SBAS Overview* in *Volume 1* of this manual set and the *Conventions* section below for more information.

This manual does not address any of the receiver hardware attributes or installation information. Please consult *Volume 1* of this manual set for technical information on these topics. Furthermore, should you encounter any functional, operational, or interfacing difficulties with the receiver, consult *Volume 1* of this manual set for NovAtel warranty and customer support information.

User Manual Updates

The most up-to-date version of this manual set and addendums can be downloaded from the [Documentation Updates](#) section of www.novatel.com.

Prerequisites

As this reference manual is focused on the OEM4 family commands and logging protocol, it is necessary to ensure that the receiver has been properly installed and powered up according to the instructions outlined in the companion *OEM4 Family User Manual Volume 1* before proceeding.

Conventions

This manual covers the full performance capabilities of all OEM4 family of receivers. Feature-tagging symbols have been created to help clarify which commands and logs are only available with the RT-2 or RT-20 option or if there is only partial implementation of this feature:

<i>RTK</i>	Features available only with receivers equipped with the <u>RT-20 or RT-2 option</u>
<i>DGPS</i>	Feature used when operating in differential mode
<i>NMEA</i>	National Marine Electronics Association format, see <i>Message Formats</i> in <i>Volume 1</i> of this manual set
<i>SBAS</i>	SBAS messages can be generated if you have an SBAS capable receiver model and are tracking an SBAS satellite. For more information refer to the <i>SBAS Overview</i> in <i>Volume 1</i> of this manual set.

Other simple conventions are:

H	The letter H in the Binary Byte or Binary Offset columns of the commands and logs tables represents the header length for that command or log, see <i>Section 1.1.3, Binary on Page 16</i>
0x	The number following 0x is a hexadecimal number

When default values are shown in command tables, they indicate the assumed values when optional parameters have been omitted. Default values do not imply the factory default settings, see *Chapter 2, Page 40* for a list of factory default settings.

Command descriptions use the bracket symbols, [], to represent the optionality of parameters.

In tables where values are missing they should be assumed to be reserved for future use.

Status words are output as hexadecimal numbers and must be converted to binary format (and in some cases then also to decimal). For an example of this type of conversion, please see the RANGE log, *Table 63, Channel Tracking Example on Page 239*. Conversions and their binary or decimal results are always read from right to left. For a complete list of hexadecimal, binary and decimal equivalents, please refer to the *Unit Conversion* section of the *GPS+ Reference Manual* available on our website at <http://www.novatel.com/support/docupdates.htm>.

ASCII log examples may be split over several lines for readability. In reality only a single [CR][LF] pair is transmitted at the end of an ASCII log.

The terms OEM4-G2, and OEM4-G2L will not be used in this manual unless a specific detail refers to it alone. The term receiver will infer that the text is applicable to an OEM4-G2L, or OEM4-G2, either stand-alone or in an enclosure, unless otherwise stated.

All of the relevant SBAS commands and logs start with WAAS except for RAWWAASFRAME. Generally, the PRN field of the WAASx logs is common, and indicates the SBAS satellite that the message originated from. Please refer to the RTCA document *RTCA DO-229B, Appendix A Wide Area Augmentation System Signal Specification* for detail on the SBAS logs.

What's New in Firmware Version 2.310 Since Version 2.300

1. A new PASSTOPASSMODE command for advanced users has been added that allows you to enable/disable different solution smoothing modes, see *Page 100*.
2. An example has been added for the COMCONTROL log to show how to enable/disable a break condition for an OEM4-G2 card, see *Page 62*.
3. The serial port interface modes table has been revised where 'tunnel' values TCOM1, TCOM2, TCOM3 and TAUX have been added. Please see *Table 28* starting on *Page 88*.
4. A note and example has been added for the ASSIGNLBAND command due to OmniSTAR's changed channels (frequencies) on the AMSC Satellite that broadcasts OmniSTAR corrections for North America. NovAtel receivers do not need a firmware change. Instead, issue an ASSIGNLBAND command to change the frequencies, see *Page 52*. Also, the ASSIGNLBAND factory default parameters have changed, see *Page 40*.
5. A correction has been made to the descriptions of the BSLNXYZ fields where they are for baseline and not position data, see *Page 171*. Also, BSLNXYZ was removed from the list of logs affected by the MOVINGBASESTATION command, see *Page 98*.
6. A footnote has been added to the undulation fields of position logs. It states that when using a datum other than WGS84, the undulation value also includes the vertical shift due to differences between the datum in use and WGS84.

1.1 Message Types

The receiver handles all incoming and outgoing NovAtel data in three different message formats: Abbreviated ASCII, ASCII, and Binary. This allows for a great deal of versatility in the way the OEM4 family receivers can be used. All NovAtel commands and logs can be entered, transmitted, output or received in any of the three formats. The receiver also supports RTCA, RTCMV3, RTCM, CMR and NMEA format messaging, see the chapter on *Message Formats* in *Volume 1* of this manual set.

When entering an ASCII or abbreviated ASCII command in order to request an output log, the message type is indicated by the character appended to the end of the message name. ‘A’ indicates that the message is ASCII and ‘B’ indicates that it is binary. No character means that the message is Abbreviated ASCII. When issuing binary commands the output message type is dependant on the bit format in the message’s binary header, see *Binary on Page 16*.

The following table describes the field types used in the description of messages.

Table 1: Field Types

Type	Binary Size (bytes)	Description
Char	1	The char type is an 8-bit integer in the range -128 to +127. This integer value may be the ASCII code corresponding to the specified character. In ASCII or Abbreviated ASCII this comes out as an actual character.
UChar	1	The uchar type is an 8-bit unsigned integer. Values are in the range from +0 to +255. In ASCII or Abbreviated ASCII this comes out as a number.
Short	2	The short type is 16-bit integer in the range -32768 to +32767.
UShort	2	The same as Short except that it is not signed. Values are in the range from +0 to +65535.
Long	4	The long type is 32-bit integer in the range -2147483648 to +2147483647.
ULong	4	The same as Long except that it is not signed. Values are in the range from +0 to +4294967295.
Double	8	The double type contains 64 bits: 1 for sign, 11 for the exponent, and 52 for the mantissa. Its range is $\pm 1.7E308$ with at least 15 digits of precision. This is IEEE 754.
Float	4	The float type contains 32 bits: 1 for the sign, 8 for the exponent, and 23 for the mantissa. Its range is $\pm 3.4E38$ with at least 7 digits of precision. This is IEEE 754.
Enum	4	A 4-byte enumerated type beginning at zero (an unsigned long). In binary, the enumerated value is output. In ASCII or Abbreviated ASCII, the enumeration label is spelled out.
GPSTime	4	This type has two separate formats that depend on whether you have requested a binary or an ASCII format output. For binary the output is in milliseconds and is a long type. For ASCII the output is in seconds and is a float type.
Hex	n	Hex is a packed, fixed length (n) array of bytes in binary but in ASCII or Abbreviated ASCII is converted into 2 character hexadecimal pairs.
String	n	String is a variable length array of bytes that is null-terminated in the binary case and additional bytes of padding are added to maintain 4 byte alignment. The maximum byte length for each String field is shown in their row in the log or command tables.

Table 2: Byte Arrangements

Table 2 shows the arrangement of bytes within each field type when used by IBM PC computers. All data sent to or from the OEM4 family receiver, however, is read least significant bit (LSB) first, opposite to what is shown in Table 2. Data is then stored in the receiver LSB first. For example, in char type data, the LSB is bit 0 and the most significant bit (MSB) is bit 7. See Table 63, *Channel Tracking Example on Page 239* for a more detailed example.

1.1.1 ASCII

ASCII messages are readable by both the user and a computer. The structures of all ASCII messages follow the general conventions as noted here:

1. The lead code identifier for each record is '#'.
2. Each log or command is of variable length depending on amount of data and formats.
3. All data fields are delimited by a comma ',' with two exceptions. The first exception is the last header field which is followed by a semi-colon ';' to denote the start of the data message. The other exception is the last data field, which is followed by a * to indicate end of message data.
4. Each log ends with a hexadecimal number preceded by an asterisk and followed by a line termination using the carriage return and line feed characters, for example, *1234ABCD[CR][LF]. This value is a 32-bit CRC of all bytes in the log, excluding the '#' identifier and the asterisk preceding the four checksum digits. See *32-Bit CRC on Page 24* for the algorithm used to generate the CRC.
5. An ASCII string is one field and is surrounded by double quotation marks, for example, "ASCII string". If separators are surrounded by quotation marks then the string is still one field and the separator will be ignored, for example, "xxx,xxx" is one field. Double quotation marks within a string are not allowed.
6. If the receiver detects an error parsing an input message, it will return an error response message. Please see *Chapter 4, Responses on Page 349* for a list of response messages from the receiver.

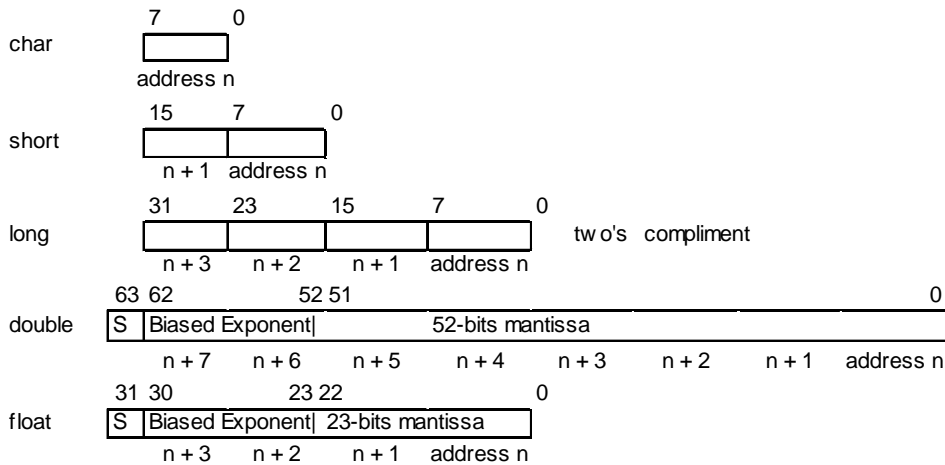
Message Structure:



The ASCII message header is formatted as follows:

Table 3: ASCII Message Header Structure

Field #	Field Name	Field Type	Description	Ignored on Input
1	Sync	Char	Sync character. The ASCII message is always preceded by a single '#' symbol.	N
2	Message	Char	This is the ASCII name of the log (see a list of all the logs in <i>Table 42, Logs By Function Table on Page 140</i>).	N
3	Port	Char	This is the name of the port from which the log was generated. The string is made up of the port name followed by an _x where x is a number from 1 to 31 denoting the virtual address of the port. If no virtual address is indicated, it is assumed to be address 0.	Y
4	Sequence #	Long	This is used for multiple related logs. It is a number that counts down from N-1 to 0 where 0 means it is the last one of the set. Most logs only come out one at a time in which case this number is 0.	N
5	% Idle Time	Float	The minimum percentage of time that the processor is idle between successive logs with the same Message ID.	Y
6	GPS Time Status	Enum	This value indicates the quality of the GPS time (see <i>Table 7, GPS Time Status on Page 21</i>)	Y
7	Week	Ulong	GPS week number.	Y
8	Seconds	GPSec	Seconds from the beginning of the GPS week accurate to the millisecond level.	Y
9	Receiver Status	Ulong	This is an eight digit hexadecimal number representing the status of various hardware and software components of the receiver between successive logs with the same Message ID (see <i>Table 81, Receiver Status on Page 303</i>).	Y
10	Reserved	Ulong	Reserved for internal use.	Y
11	Receiver s/w Version	Ulong	This is a value (0 - 65535) that represents the receiver software build number.	Y
12	;	Char	This character indicates the end of the header.	N

Example Log:

```
#RAWEPHEMA, COM1, 0, 81.5, SATTIME, 1262, 488670.000, 00000000, 97b7, 1522;
14, 1262, 489600, 8b03b89f13253b90002ba3db7949b427b21dbe7aeae6778800ffefed9748, 8b0
3b89f112ae609952f1d85e6f79c087000cba26308b6a10cad2977887d, 8b03b89f11ac0000acd77
614fff927cc00c026b4c6904cdaffa6c3e610b0*bccbb2db [CR] [LF]
```

1.1.2 Abbreviated ASCII

This message format is designed to make the entering and viewing of commands and logs by the user as simple as possible. The data is represented as simple ASCII characters separated by spaces or commas and arranged in an easy to understand fashion. There is also no 32-bit CRC for error detection because it is meant for viewing by the user.

Example Command:

```
log com1 loglist
```

Resultant Log:

```
<LOGLIST COM1 0 69.0 FINE 0 0.000 00240000 206d 0
<      4
<      COM1 RXSTATUSEVENTA ONNEW 0.000000 0.000000 NOHOLD
<      COM2 RXSTATUSEVENTA ONNEW 0.000000 0.000000 NOHOLD
<      COM3 RXSTATUSEVENTA ONNEW 0.000000 0.000000 NOHOLD
<      COM1 LOGLIST ONCE 0.000000 0.000000 NOHOLD
```

As you can see the array of 4 logs are offset from the left hand side and start with '<'.

1.1.3 Binary

Binary messages are meant strictly as a machine readable format. They are also ideal for applications where the amount of data being transmitted is fairly high. Because of the inherent compactness of binary as opposed to ASCII data, the messages are much smaller. This allows a larger amount of data to be transmitted and received by the receiver's communication ports. The structure of all Binary messages follows the general conventions as noted here:

1. Basic format of:

Header	3 Sync bytes plus 25 bytes of header information. The header length is variable as fields may be appended in the future. Always check the header length.
Data	variable
CRC	4 bytes

2. The 3 Sync bytes will always be:

Byte	Hex	Decimal
First	AA	170
Second	44	68
Third	12	18

- The CRC is a 32-bit CRC (see *32-Bit CRC on Page 24* for the CRC algorithm) performed on all data including the header.
- The header is in the format shown in *Table 4, Binary Message Header Structure on Page 17*.

Table 4: Binary Message Header Structure

Field #	Field Name	Field Type	Description	Binary Bytes	Binary Offset	Ignored on Input
1	Sync	Char	Hexadecimal 0xAA.	1	0	N
2	Sync	Char	Hexadecimal 0x44.	1	1	N
3	Sync	Char	Hexadecimal 0x12.	1	2	N
4	Header Lgth	Uchar	Length of the header.	1	3	N
5	Message ID	Ushort	This is the Message ID number of the log (see the log descriptions in <i>Table 44, OEM4 Family Logs in Order of their Message IDs on Page 151</i> for the Message ID values of individual logs).	2	4	N
6	Message Type	Char	Bits 0-4 = Reserved Bits 5-6 = Format 00 = Binary 01 = ASCII 10 = Abbreviated ASCII, NMEA 11 = Reserved Bit 7 = Response bit (see <i>Section 1.2, Page 20</i>) 0 = Original Message 1 = Response Message	1	6	N
7	Port Address	Uchar	See <i>Table 5 on Page 18</i> (decimal values greater than 16 may be used) (lower 8 bits only) ^a	1	7	N ^b
8	Message Length	Ushort	The length in bytes of the body of the message. This does not include the header nor the CRC.	2	8	N
9	Sequence	Ushort	This is used for multiple related logs. It is a number that counts down from N-1 to 0 where N is the number of related logs and 0 means it is the last one of the set. Most logs only come out one at a time in which case this number is 0.	2	10	N
10	Idle Time	Uchar	The time that the processor is idle in the last second between successive logs with the same Message ID. Take the time (0 - 200) and divide by two to give the percentage of time (0 - 100%).	1	12	Y
11	Time Status	Enum	Indicates the quality of the GPS time (see <i>Table 7, GPS Time Status on Page 21</i>).	1 ^c	13	N ^d
12	Week	Ushort	GPS week number.	2	14	N ^d
13	Milliseconds	GPSec	Milliseconds from the beginning of the GPS week.	4	16	N ^d
14	Receiver Status	Ulong	32 bits representing the status of various hardware and software components of the receiver between successive logs with the same Message ID (see <i>Table 81, Receiver Status on Page 303</i>)	4	20	Y
15	Reserved	Ushort	Reserved for internal use.	2	24	Y
16	Receiver S/W Version	Ushort	This is a value (0 - 65535) that represents the receiver software build number.	2	26	Y

- The 8 bit size means that you will only see 0xA0 to 0xBF when the top bits are dropped from a port value greater than 8 bits. For example ASCII port USB1 will be seen as 0x5A in the binary output.
- Recommended value is THISPORT (binary 192)
- This ENUM is not 4 bytes long but, as indicated in the table, is only 1 byte.
- These time fields are ignored if Field #11, Time Status, is invalid. In this case the current receiver time is used. The recommended values for the three time fields are 0, 0, 0.

Table 5: Detailed Serial Port Identifiers

ASCII Port Name	Hex Port Value	Decimal Port Value ^a	Description
NO_PORTS	0	0	No ports specified
COM1_ALL	1	1	All virtual ports for COM port 1
COM2_ALL	2	2	All virtual ports for COM port 2
COM3_ALL	3	3	All virtual ports for COM port 3
THISPORT_ALL	6	6	All virtual ports for the current port
ALL_PORTS	8	8	All virtual ports for all ports
XCOM1_ALL	9	9	All virtual COM1 ports
XCOM2_ALL	10	10	All virtual COM2 ports
USB1_ALL	d	13	All virtual ports for USB port 1
USB2_ALL	e	14	All virtual ports for USB port 2
USB3_ALL	f	15	All virtual ports for USB port 3
AUX_ALL	10	16	All virtual ports for the AUX port ^b
XCOM3_ALL	11	17	All virtual COM3 ports
COM1	20	32	COM port 1, virtual port 0
COM1_1	21	33	COM port 1, virtual port 1
...			
COM1_31	3f	63	COM port 1, virtual port 31
COM2	40	64	COM port 2, virtual port 0
...			
COM2_31	5f	95	COM port 2, virtual port 31
COM3	60	96	COM port 3, virtual port 0
...			
COM3_31	7f	127	COM port 3, virtual port 31
USB	80	128	USB port, virtual port 0
...			
USB_31	9f	159	USB port, virtual port 31
SPECIAL	a0	160	Unknown port, virtual port 0
...			
SPECIAL_31	bf	191	Unknown port, virtual port 31
THISPORT	c0	192	Current COM port, virtual port 0
...			
THISPORT_31	df	223	Current COM port, virtual port 31
XCOM1	1a0	416	Virtual COM1 port, virtual port 0
XCOM1_1	1a1	417	Virtual COM1 port, virtual port 1
...			
XCOM1_31	1bf	447	Virtual COM1 port, virtual port 31

Continued on Page 19

ASCII Port Name	Hex Port Value	Decimal Port Value ^a	Description
XCOM2	2a0	672	Virtual COM2 port, virtual port 0
XCOM2_1	2a1	673	Virtual COM2 port, virtual port 1
...			
XCOM2_31	2bf	703	Virtual COM2 port, virtual port 31
USB1	5a0	1440	USB port 1, virtual port 0
USB1_1	5a1	1441	USB port 1, virtual port 1
...			
USB1_31	5bf	1471	USB port 1, virtual port 31
USB2	6a0	1696	USB port 2, virtual port 0
...			
USB2_31	6bf	1727	USB port 2, virtual port 31
USB3	7a0	1952	USB port 3, virtual port 0
...			
USB3_31	7bf	1983	USB port 3, virtual port 31
AUX	8a0	2208	AUX port, virtual port 0 ^b
...			
AUX_31	8bf	2239	AUX port, virtual port 31 ^b
XCOM3	9a0	2464	Virtual COM3 port, virtual port 0
XCOM3_1	9a1	2465	Virtual COM3 port, virtual port 1
...			
XCOM3_31	9bf	2495	Virtual COM3 port, virtual port 31

- a. Decimal port values 0 through 16 are only available to the UNLOGALL command, see *Page 132*, and cannot be used in the UNLOG command, *Page 131*, or in the binary message header, see *Table 4 on Page 17*.
- b. The AUX port is only available on OEM4-G2-based (hardware Rev. 3 and higher) and DL-4 products.

☒ COM1_ALL, COM2_ALL, COM3_ALL, THISPORT_ALL, ALL_PORTS, USB1_ALL, USB2_ALL, USB3_ALL and AUX_ALL are only valid for the UNLOGALL command.

1.2 Responses

By default, if you input a message you will get back a response. If desired, the INTERFACEMODE command can be used to disable response messages (see *Page 87*). The response will be in the exact format that you entered the message (that is, binary input = binary response).

Abbreviated Response

Just the leading '<' followed by the response string, for example:

```
<OK
```

ASCII Response

Full header with the message name being identical except ending in an 'R' (for response). The body of the message consists of a 40 character string for the response string, for example:

```
#BESTPOSR,COM1,0,67.0,FINE,1028,422060.400,00000000,a31b,0;"OK" *b867caad
```

Binary Response

Similar to an ASCII response except that it follows the binary protocols:

- Binary header with message type set to response value (for example, 0x82), see *Field 6 in Table 4, Binary Message Header Structure on Page 17*.
- ENUM response ID, see *Table 92, Response Messages on Page 349*.
- String containing the ASCII response to match the ENUM response ID above (for example, 0x4F04B = OK)

Table 6, Binary Message Sequence on Page 21 is an example of the sequence for requesting and then receiving BESTPOSB. The example is in hex format. When you enter a hex command, you may need to add a '\x' or '0x' before each hex pair, depending on your code (for example, 0xAA0x440x120x1C0x010x000x02 and so on).

Table 6: Binary Message Sequence

Direction	Sequence	Data
To Receiver	LOG Command Header	AA44121C 01000240 20000000 1D1D0000 29160000 00004C00 55525A80
	LOG Parameters	20000000 2A000000 02000000 00000000 0000F03F 00000000 00000000 00000000
	Checksum	2304B3F1
From Receiver	LOG Response Header	AA44121C 01008220 06000000 FFB4EE04 605A0513 00004C00 FFFF5A80
	Log Response Data	01000000 4F4B
	Checksum	DA8688EC
From Receiver	BESTPOSB Header	AA44121C 2A000220 48000000 A5B4EE04 888F2013 00000000 A64CF205
	BESTPOSB Data	00000000 10000000 2A11CF8F E68E4940 ED818CFE 73825CC0 00F0A903 A19A9040 732B82C1 3D000000 6F7DF33F BACFC33F 9DE58940 00000000 00000000 00000000 07070000 00000000
	Checksum	0C0458B7

1.3 GPS Time Status

All reported receiver times are subject to a qualifying time status. This status gives you an indication of how well a time is known, see *Table 7*:

Table 7: GPS Time Status

GPS Time Status (Decimal)	GPS Time Status ^a (ASCII)	Description
20	UNKNOWN	Time validity is unknown.
60	APPROXIMATE	Time is set approximately.
80	COARSEADJUSTING	Time is approaching coarse precision.
100	COARSE	This time is valid to coarse precision.
120	COARSESTEERING	Time is coarse set, and is being steered.
130	FREEWHEELING	Position is lost, and the range bias cannot be calculated.
140	FINEADJUSTING	Time is adjusting to fine precision.
160	FINE	Time has fine precision.
180	FINESTEERING	Time is fine, set and is being steered.
200	SATTIME	Time from satellite. This is only used in logs containing satellite data such as ephemeris and almanac.

a. See also *Section 1.4, Message Time Stamps on Page 23*

There are several distinct states that the receiver will go through:

- UNKNOWN
- COARSE
- FREEWHEELING
- FINE
- FINESTEERING

On start up, and before any satellites are being tracked, the receiver can not possibly know the current time. As such, the receiver time starts counting at GPS week 0 and second 0.0. The time status flag is set to UNKNOWN.

If time is input to the receiver using the SETAPPROXTIME command, see *Page 122*, or on receipt of an RTCAEPHEM message, see *Page 201*, the time status will be APPROXIMATE.

After the first ephemeris is decoded, the receiver time is set to a resolution of ± 10 milliseconds. This state is qualified by the COARSE or COARSESTEERING time status flag depending on the state of the CLOCKADJUST switch.

Once a position is known and range biases are being calculated, the internal clock model will begin modelling the position range biases and the receiver clock offset.

Modelling will continue until the model is a good estimation of the actual receiver clock behavior. At this time, the receiver time will again be adjusted, this time to an accuracy of ± 1 microsecond. This state is qualified by the FINE time status flag.

The final logical time status flag depends on whether CLOCKADJUST is enabled or not, see *Page 55*. If CLOCKADJUST is disabled, the time status flag will never improve on FINE. The time will only be adjusted again to within ± 1 microsecond if the range bias gets larger than ± 250 milliseconds. If ClockAdjust is enabled, the time status flag will be set to FINESTEERING and the receiver time will be continuously updated (steered) to minimize the receiver range bias.

If for some reason position is lost and the range bias cannot be calculated, the time status will be degraded to FREEWHEELING.

1.4 Message Time Stamps

All NovAtel format messages generated by the OEM4 family receivers have a GPS time stamp in their header. GPS time is referenced to UTC with zero point defined as midnight on the night of January 5 1980. The time stamp consists of the number of weeks since that zero point and the number of seconds since the last week number change (0 to 604,799). GPS time differs from UTC time since leap seconds are occasionally inserted into UTC but GPS time is continuous. In addition a small error (less than 1 microsecond) can exist in synchronization between UTC and GPS time. The TIME log reports both GPS and UTC time and the offset between the two.

The data in synchronous logs (for example, RANGE, BESTPOS, TIME) are based on a periodic measurement of satellite pseudoranges. The time stamp on these logs is the receiver estimate of GPS time at the time of the measurement. When setting time in external equipment, a small synchronous log with a high baud rate will be accurate to a fraction of a second. A synchronous log with trigger ONTIME 1 can be used in conjunction with the 1PPS signal to provide relative accuracy better than 250 ns.

Other log types (asynchronous and polled) are triggered by an external event and the time in the header may not be synchronized to the current GPS time. Logs that contain satellite broadcast data (for example, ALMANAC, GPSEPHM) have the transmit time of their last subframe in the header. In the header of differential time matched logs (for example, MATCHEDPOS) is the time of the matched reference and local observation that they are based on. Logs triggered by a mark event (for example, MARKEDPOS, MARKTIME) have the estimated GPS time of the mark event in their header. In the header of polled logs (for example, LOGLIST, PORTSTATS, VERSION) is the approximate GPS time when their data was generated. However, when asynchronous logs are triggered ONTIME, the time stamp will represent the time the log was generated, not the time given in the data.

1.5 Decoding of the GPS Week Number

The GPS week number provided in the raw satellite data is the 10 least significant bits (or 8 least significant bits in the case of the almanac data) of the full week number. When the receiver processes the satellite data, the week number is decoded in the context of the current era and, therefore, is computed as the full week number starting from week 0 or January 6, 1980. Therefore, in all log headers and decoded week number fields, the full week number is given. Only in raw data, such as the *data* field of the RAWALM log or the *subframe* field of the RAWEPHEM log, will the week number remain as the 10 (or 8) least significant bits.

1.6 32-Bit CRC

The ASCII and Binary OEM4 family message formats all contain a 32-bit CRC for data verification. This allows the user to ensure that the data received (or transmitted) is valid with a high level of certainty. This CRC can be generated using the following C algorithm:

```
#define CRC32_POLYNOMIAL 0xEDB88320L
/* -----
Calculate a CRC value to be used by CRC calculation functions.
----- */
unsigned long CRC32Value(int i)
{
    int j;
    unsigned long ulCRC;
    ulCRC = i;
    for ( j = 8 ; j > 0; j-- )
    {
        if ( ulCRC & 1 )
            ulCRC = ( ulCRC >> 1 ) ^ CRC32_POLYNOMIAL;
        else
            ulCRC >>= 1;
    }
    return ulCRC;
}
/* -----
Calculates the CRC-32 of a block of data all at once
----- */
unsigned long CalculateBlockCRC32(
    unsigned long ulCount, /* Number of bytes in the data block */
    unsigned char *ucBuffer ) /* Data block */
{
    unsigned long ulTemp1;
    unsigned long ulTemp2;
    unsigned long ulCRC = 0;
    while ( ulCount-- != 0 )
    {
        ulTemp1 = ( ulCRC >> 8 ) & 0x00FFFFFFL;
        ulTemp2 = CRC32Value( ((int) ulCRC ^ *ucBuffer++) & 0xff );
        ulCRC = ulTemp1 ^ ulTemp2;
    }
    return( ulCRC );
}
```

- ☒ The NMEA checksum is an XOR of all the bytes (including delimiters such as ',' but excluding the * and \$) in the message output. It is therefore an 8-bit and not a 32-bit checksum for NMEA logs.

At the time of writing, a log may not yet be available. Every effort is made to ensure that examples are correct, however, a checksum may be created for promptness in publication. In this case it will appear as '9999'.

Example:

BESTPOSA and BESTPOSB from an OEM4 family receiver.

ASCII:

```
#BESTPOSA,COM2,0,77.5,FINESTEERING,1285,160578.000,00000020,5941,1164;
SOL_COMPUTED,SINGLE,51.11640941570,-114.03830951024,1062.6963,-16.2712,
WGS84,1.6890,1.2564,2.7826,"",0.000,0.000,10,10,0,0,0,0,0*2212A3C3
```

BINARY:

```
0xAA, 0x44, 0x12, 0x1C, 0x2A, 0x00, 0x02, 0x42, 0x48, 0x00, 0x00, 0x00, 0x96, 0xB4,
0x05, 0x05, 0x90, 0x32, 0x8E, 0x09, 0x20, 0x00, 0x00, 0x00, 0x41, 0x59, 0x8C, 0x04,
0x00, 0x00, 0x00, 0x00, 0x10, 0x00, 0x00, 0x00, 0x03, 0x9A, 0x8A, 0x8A, 0xE6, 0x8E,
0x49, 0x40, 0xEB, 0xD8, 0xE7, 0xB2, 0x73, 0x82, 0x5C, 0xC0, 0x00, 0xB0, 0xDD,
0xA2, 0x37, 0x9B, 0x90, 0x40, 0x80, 0x2B, 0x82, 0xC1, 0x3D, 0x00, 0x00, 0x00, 0x9D,
0xDA, 0x3F, 0xF7, 0x58, 0xA1, 0x3F, 0x3F, 0xF4, 0x32, 0x89, 0x40, 0x00, 0x00, 0x00,
0x00, 0x00, 0x00, 0x00, 0x00, 0x00, 0x00, 0x00, 0x0A, 0x0A, 0x00, 0x00, 0x00,
0x00, 0x00, 0x00, 0x880xF50x420x8D
```

Below is a demonstration of how to generate the CRC from both ASCII and BINARY messages using the function described above.

☒ When you pass the data into the code below, exclude the checksum shown in *bold italics* above.

ASCII:

```
#include <iostream.h>
#include <string.h>
void main()
{
char *i = "BESTPOSA,COM2,0,77.5,FINESTEERING,1285,160578.000,00000020,5941,1164;
SOL_COMPUTED,SINGLE,51.11640941570,-114.03830951024,1062.6963,-16.2712,
WGS84,1.6890,1.2564,2.7826,"",0.000,0.000,10,10,0,0,0,0,0";
unsigned long iLen = strlen(i);
unsigned long CRC = CalculateBlockCRC32(iLen, (unsigned char*));
cout << hex << CRC << endl;
}
```

BINARY:

```
#include <iostream.h>
#include <string.h>
int main()
{
unsigned char buffer[] = {0xAA, 0x44, 0x12, 0x1C, 0x2A, 0x00, 0x02, 0x42, 0x48, 0x00, 0x00, 0x00, 0x96, 0xB4, 0x05, 0x05,
0x90, 0x32, 0x8E, 0x09, 0x20, 0x00, 0x00, 0x00, 0x41, 0x59, 0x8C, 0x04, 0x00, 0x00, 0x00, 0x00, 0x10, 0x00, 0x00, 0x00,
0x03, 0x9A, 0x8A, 0x8A, 0xE6, 0x8E, 0x49, 0x40, 0xEB, 0xD8, 0xE7, 0xB2, 0x73, 0x82, 0x5C, 0xC0, 0x00, 0xB0, 0xDD,
0xA2, 0x37, 0x9B, 0x90, 0x40, 0x80, 0x2B, 0x82, 0xC1, 0x3D, 0x00, 0x00, 0x00, 0x00, 0x9D, 0xDA, 0x3F, 0xF7, 0x58, 0xA1,
0x3F, 0x3F, 0xF4, 0x32, 0x89, 0x40, 0x00, 0x00, 0x00, 0x00, 0x00, 0x00, 0x00, 0x00, 0x00, 0x00, 0x00, 0x00, 0x0A, 0x0A,
0x00, 0x00, 0x00, 0x00, 0x00};
unsigned long crc = CalculateBlockCRC32(60, buffer);
cout << hex << crc << endl;

//Please note that this hex needs to be reversed due to Big Endian order where the most significant value in the sequence is
stored first (at the lowest storage address). For example, the two bytes required for the hex number 4F52 is stored as 524F.
}
```

2.1 Command Formats

The receiver accepts commands in 3 formats as described in *Chapter 1*:

- Abbreviated ASCII
- ASCII
- Binary

Abbreviated ASCII is the easiest format to use for your input. The other two formats include a CRC for error checking and are intended for use when interfacing with other electronic equipment.

Here are examples of the same command in each format:

Abbreviated ASCII Example:

```
LOG COM2 BESTPOSB ONTIME 1 [CR]
```

ASCII Example:

```
LOGA,COM2,0,66.0,UNKNOWN,0,15.917,004c0000,5255,32858;COM1,BESTPOSB,  
ONTIME,1.000000,0.000000,NOHOLD*F95592DD [CR]
```

Binary Example:

```
AA44121C 01000240 20000000 1D1D0000 29160000 00004C00 55525A80 20000000  
2A000000 02000000 00000000 0000F03F 00000000 00000000 00000000 2304B3F1
```

2.2 Command Settings

There are several ways to determine the current command settings of the receiver:

1. Request an RXCONFIG log, see *Page 297*. This will provide a listing of all commands and their parameter settings. This log provides the most complete information, but the size and format do not make it easy to read.
2. For some specific commands, logs are available to indicate all their parameter settings. The LOGLIST log, see *Page 212*, will show all active logs in the receiver beginning with the LOG command. The COMCONFIG log, see *Page 180*, will show both the COM and INTERFACEMODE commands parameter settings for all serial ports.
3. Request a log of the specific command of interest. This will show the parameters last entered for that command. The format of the log produced is exactly the same as the format of the specific command with updated header information.
4. This is very useful for most commands, but for commands that are repeated with different parameters (for example, COM, LOG, and INTERFACEMODE), this will only show the most recent set of parameters used. To see all sets of parameters try method 1 or 2 above.

Abbreviated ASCII Example:

```
log fix
<FIX COM1 0 45.0 FINE 1114 151898.288 00200000 dbfd 33123
<      NONE -10000.000000000000 -10000.000000000000 -10000.0000
```

2.3 Commands by Function

Table 8 lists the commands by function while Table 9 on Page 31 is an alphabetical listing of commands (repeated in Table 10 on Page 35 with the commands in the order of their message IDs). Please see 2.6, Command Reference on Page 42 for a more detailed description of individual commands which are listed alphabetically.

Table 8: Commands By Function Table

COMMUNICATIONS, CONTROL AND STATUS	
Commands	Descriptions
ANTENNAPOWER	Control power to low-noise amplifier (LNA) of an active antenna
COM	Set COM port configuration
COMCONTROL	Control the hardware control lines of the RS232 ports
FREQUENCYOUT	Set the output pulse train available on VARF
INTERFACEMODE	Set interface type, Receive (Rx)/Transmit (Tx), for a port
LOG	Request a log
MARKCONTROL	Control processing of the mark inputs
PPSCONTROL	Control the PPS output
SEND	Send ASCII message to a port
SENDEX	Send non-printable characters to a port
SETRTCM16	Enter ASCII message to be sent in RTCM data stream
UNLOG, UNLOGALL	Remove one or all logs from logging control

GENERAL RECEIVER CONTROL	
Commands	Descriptions
AUTH	Add authorization code for new model
DYNAMICS	Tune receiver parameters

Continued on Page 28

GENERAL RECEIVER CONTROL	
Commands	Descriptions
RESET	Perform a hardware reset
FRESET	Reset receiver to factory default
MODEL	Switch receiver to a previously AUTHed model
NVMRESTORE	Restore NVM data after a failure in NVM
SAVECONFIG	Save current configuration
STATUSCONFIG	Configure various status mask fields in RXSTATUSEVENT log

POSITION, PARAMETERS, AND SOLUTION FILTERING CONTROL	
Commands	Descriptions
CSMOOTH	Set amount of carrier smoothing
DATUM	Choose a DATUM name type
ECUTOFF	Set satellite elevation cut-off for solutions
FIX	Constrain receiver height or position
FIXPOSDATUM	Set the position through a specified datum
GGAQUALITY	Customize the GPGGA GPS quality indicator
HPSEED	Specify the seed position for OmniSTAR HP
HPSTATICINIT	Set static initialization of OmniSTAR HP
PASSTOPASSMODE	Enable/disable solution smoothing modes
POSTIMEOUT	Sets the position time out value
RTKBASLINE	Initialize RTK with a static baseline
RTKCOMMAND	Reset the RTK filter or set the filter to default settings
RTKDYNAMICS	Setup the RTK dynamics mode
RTKELEV MASK	Set the minimum elevation mask angle for satellites to include in RTK corrections
RTKSOLUTION	Set RTK carrier phase ambiguity type (Float or Fixed)
SBASCONTROL	Set SBAS test mode and PRN

Continued on Page 29

POSITION, PARAMETERS, AND SOLUTION FILTERING CONTROL	
Commands	Descriptions
UNDULATION	Set ellipsoid-geoid separation
USERDATUM	Set user-customized datum
USEREXPDATUM	Set custom expanded datum
UTMZONE	Set UTM parameters

SATELLITE TRACKING AND CHANNEL CONTROL	
Commands	Descriptions
ASSIGN	Assign individual satellite channel
ASSIGNALL	Assign all satellite channels
DYNAMICS	Tune receiver parameters
ECUTOFF	Set satellite tracking elevation cut-off
SETAPPROXPOS	Set an approximate position
SETAPPROXTIME	Set an approximate GPS time
UNASSIGN	Unassign a previously ASSIGNED channel
UNASSIGNALL	Unassign all previously ASSIGNED channels
WAASECUTOFF	Set SBAS satellite elevation cut-off

WAYPOINT NAVIGATION	
Commands	Descriptions
MAGVAR	Set magnetic variation correction
SETNAV	Set waypoints

DIFFERENTIAL BASE STATION	
Commands	Descriptions
DGPSEPHEMDELAY	DGPS ephemeris delay
DGPSTXID	DGPS transmit ID

Continued on Page 30

DIFFERENTIAL BASE STATION	
Commands	Descriptions
FIX	Constrain receiver height or position
INTERFACEMODE	Set interface type Transmit (Tx), for a port
LOG	Select required differential-output log
MOVINGBASESTATION	Set ability to use a moving base station position
POSAVE	Set up position averaging
FIXPOSDATUM	Fix position through a datum
RTKELEV MASK	Set the minimum elevation mask angle for satellites to include in RTK corrections
RTKSVENTRIES	Set the number of satellites to include in RTK corrections

DIFFERENTIAL ROVER STATION	
Commands	Descriptions
ASSIGNLBAND	Set L-Band satellite communication parameters
DGPSTIMEOUT	Set maximum age of differential data accepted
INTERFACEMODE	Set interface type, Receive (Rx), for a COM port
PSRDIFFSOURCE	Set the pseudorange correction source
RTKDYNAMICS	Set the RTK dynamics mode
RTKBASELINE	Initialize RTK with a static baseline
RTKCOMMAND	Issue RTK specific commands
RTKELEV MASK	Set elevation mask to use for RTK positioning
RTKSOLUTION	Set RTK carrier phase ambiguity type (Float or Fixed) or disable
RTKSOURCE	Set the RTK correction source
SETAPPROXPOS	Set an approximate position
SETAPPROXTIME	Set an approximate GPS time

Continued on Page 31

CLOCK INFORMATION, STATUS, AND TIME	
Commands	Descriptions
ADJUST1PPS	Adjust the receiver clock
CLOCKADJUST	Enable or disable adjustments to the internal clock and 1PPS output
CLOCKCALIBRATE	Adjust the control parameters of the clock steering loop
CLOCKOFFSET	Adjust for antenna RF cable delay in PPS output
EXTERNALCLOCK	Set the parameters for an external clock
SETAPPROXTIME	Set an approximate time

Table 9: OEM4 Family Commands in Alphabetical Order

Command	Message ID	Description	Syntax
ADJUST1PPS	429	Adjust the receiver clock	adjust1pps mode [period] [offset]
ANTENNAPOWER	98	Control power to low-noise amplifier of an active antenna	antennapower flag
ASSIGN	27	Assign individual satellite channel to a PRN	assign channel [state] prn [Doppler [window]]
ASSIGNALL	28	Assign all satellite channels to a PRN	assignall [system] [state] prn [Doppler [window]]
ASSIGNLBAND	729	Set L-Band satellite communication parameters	assignlband mode freq baud
AUTH	49	Add authorization code for new model	auth [state] part1 part2 part3 part4 part5 model [date]
CLOCKADJUST	15	Enable clock adjustments	clockadjust switch
CLOCKCALIBRATE	430	Adjust the control parameters of the clock steering loop	clockcalibrate mode [period] [width] [slope] [bandwidth]
CLOCKOFFSET	596	Adjust for antenna RF cable delay in PPS output	clockoffset offset
COMCONTROL	431	Control the hardware control lines of the RS232 ports	comcontrol port signal control
COM	4	COM port configuration control	com [port] bps [parity [databits [stopbits [handshake [echo [break]]]]]]]
CSMOOTH	269	Set carrier smoothing	csmooth L1time [L2time]
DATUM	160	Choose a DATUM name type	datum datum

Continued on Page 32

Command	Message ID	Description	Syntax
DGPSEPHEMDELAY	142	DGPS ephemeris delay	dgpsephe delay
DGPSTIMEOUT	127	Set maximum age of differential data accepted	dgpstimeout delay
DGPSTXID	144	DGPS transmit ID	dgpstxid type ID
DYNAMICS	258	Tune receiver parameters	dynamics dynamics
ECUTOFF	50	Set satellite elevation cut-off	ecutoff angle
EXTERNALCLOCK	230	Set external clock parameters	externalclock clocktype [freq] [h0 [h1 [h2]]]
FIX	44	Constrain to fixed height or position	fix type [param1 [param2 [param3]]]
FIXPOSDATUM	761	Set the position through a specified datum	position datum [lat [lon [height]]]
FREQUENCYOUT	232	Sets the output pulse train available on VARF.	frequencyout [switch] [pulsewidth] [period]
FRESET	20	Clear almanac model, or user configuration data, which is stored in NVM and followed by a receiver reset.	freset [target]
GGAQUALITY	691	Customize the GPGGA GPS quality indicator	ggaquality #entries [pos type1][qual1] [pos type2] [qual2]...
HPSEED	782	Specify the seed position for OmniSTAR HP	hpseed mode lat lon hgt lats lons hgts datum undulation
HPSTATICINIT	780	Set static initialization of OmniSTAR HP	hpstaticinit switch
INTERFACEMODE	3	Set interface type, Receive (Rx)/Transmit (Tx), for ports	interfacemode [port] rxtype txtype [responses]
LOCKOUT	137	Prevent the receiver from using a satellite by specifying its PRN	lockout prn
LOG	1	Request logs from receiver	log [port] message [trigger [period [offset [hold]]]]
MAGVAR	180	Set magnetic variation correction	magvar type [correction [stddev]]
MARKCONTROL	614	Control the processing of the mark inputs	markcontrol signal switch [polarity] [timebias [timeguard]]

Continued on Page 33

Command	Message ID	Description	Syntax
MODEL	22	Switch to a previously AUTHed model	model model
MOVINGBASE-STATION	763	Set ability to use a moving base station position	movingbasestation switch
NVMRESTORE	197	Restore NVM data after a failure in NVM	nvmrestore
PASSTOPASSMODE	601	Enable/disable solution smoothing modes	passtopassmode switch [measmth] [corsmth] [dwt] [dwtscale]
POSAVE	173	Implement position averaging for base station	posave [state] maxtime [maxhstd [maxvstd]]
POSTIMEOUT	612	Sets the position time out	postimeout sec
FIXPOSDATUM	761	Fix position through a datum	position datum [lat [lon [height]]]
PPSCONTROL	613	Control the PPS output	ppscontrol switch [polarity] [rate]
PSRDIFFSOURCE	493	Set the pseudorange correction source	psrdiffsource type ID
RESET	18	Perform a hardware reset	reset [delay]
RTKBASELINE	182	Initialize RTK with a static baseline	rtkbaseline type [par1 par2 par3 [2sigma]]
RTKCOMMAND	97	Reset the RTK filter or set the filter to default settings	rtkcommand action
RTKDYNAMICS	183	Set the RTK dynamics mode	rtkdynamics mode
RTKELEV MASK	91	Set the RTK mask angle	rtkelevmask type [angle]
RTKSOLUTION	184	Set RTK carrier phase ambiguity type (Float or Fixed) or disable	rtksolution type
RTKSOURCE	494	Set the RTK correction source	rtksource type ID
RTKSVENTRIES	92	Set the number of satellites to use in corrections	rtksventries number
SAVECONFIG	19	Save current configuration in non-volatile memory	saveconfig
SBASCONTROL	652	Set SBAS test mode and PRN	sbascontrol keyword [prn] [testmode]
SEND	177	Send an ASCII message to any of the communications ports	send port data

Continued on Page 34

Command	Message ID	Description	Syntax
SENDHEX	178	Send non-printable characters in hexadecimal pairs	sendhex port length data
SETAPPROXPOS	377	Set an approximate position	setapproxpos lat lon height
SETAPPROXTIME	102	Set an approximate GPS time	setapproxtime week sec
SETNAV	162	Set start and destination waypoints	setnav fromlat fromlon tolat tolon track offset from-point to-point
SETRTCM16	131	Enter an ASCII text message to be sent out in the RTCM data stream	setrtcm16 text
STATUSCONFIG	95	Configure various status mask fields in RXSTATUSEVENT log	statusconfig type word mask
UNASSIGN	29	Unassign a previously ASSIGNED channel	unassign channel
UNASSIGNALL	30	Unassign all previously ASSIGNED channels	unassignall [system]
UNDULATION	214	Choose undulation	undulation option [separation]
UNLOCKOUT	138	Reinstate a satellite in the solution computation	unlockout prn
UNLOCKOUTALL	139	Reinstate all previously locked out satellites	unlockoutall
UNLOG	36	Remove log from logging control	unlog [port] datatype
UNLOGALL	38	Remove all logs from logging control	unlogall [port]
USERDATUM	78	Set user-customized datum	userdatum semimajor flattening dx dy dz rx ry rz scale
USEREXPDATUM	783	Set custom expanded datum	userexpdatum semimajor flattening dx dy dz rx ry rz scale xvel yvel zvel xrvel yrvel zrvel scalev refdate
UTMZONE	749	Set UTM parameters	utmzone command parameter
WAASECUTOFF	505	Set SBAS satellite elevation cut-off	waasecutoff angle

Table 10: OEM4 Family Commands in Order of their Message IDs

Message ID	Command	Description	Syntax
1	LOG	Request logs from receiver	log [port] message [trigger [period [offset [hold]]]]
3	INTERFACEMODE	Set interface type, Receive (Rx)/Transmit (Tx), for ports	interfacemode [port] rxtype txtype [responses]
4	COM	COM port configuration control	com [port] bps [parity [databits [stopbits [handshake [echo [break]]]]]]
15	CLOCKADJUST	Enable clock adjustments	clockadjust switch
18	RESET	Perform a hardware reset	reset [delay]
19	SAVECONFIG	Save current configuration in non-volatile memory	saveconfig
20	FRESET	Clear almanac model, or user configuration data, which is stored in NVM and followed by a receiver reset.	freset [target]
22	MODEL	Switch to a previously AUTHed model	model model
27	ASSIGN	Assign individual satellite channel to a PRN	assign channel [state] prn [Doppler [window]]
28	ASSIGNALL	Assign all satellite channels to a PRN	assignall [system] [state] prn [Doppler [window]]
29	UNASSIGN	Unassign a previously ASSIGNED channel	unassign channel
30	UNASSIGNALL	Unassign all previously ASSIGNED channels	unassignall [system]
36	UNLOG	Remove log from logging control	unlog [port] datatype
38	UNLOGALL	Remove all logs from logging control	unlogall [port]
44	FIX	Constrain to fixed height or position	fix type [param1 [param2 [param3]]]
49	AUTH	Add authorization code for new model	auth [state] part1 part2 part3 part4 part5 model [date]
50	ECUTOFF	Set satellite elevation cut-off	ecutoff angle
78	USERDATUM	Set user-customized datum	userdatum semimajor flattening dx dy dz rx ry rz scale
91	RTKELEVmask	Set the RTK mask angle	rtkelevmask type [angle]

Continued on Page 36

Message ID	Command	Description	Syntax
92	RTKSVENTRIES	Set the number of satellites to use in corrections	rtksventries number
95	STATUSCONFIG	Configure various status mask fields in RXSTATUSEVENT log	statusconfig type word mask
97	RTKCOMMAND	Reset the RTK filter or set the filter to default settings	rtkcommand action
98	ANTENNAPOWER	Control power to low-noise amplifier of an active antenna	antennapower flag
102	SETAPPROXTIME	Set an approximate GPS time	setapproxtime week sec
127	DGPSTIMEOUT	Set maximum age of differential data accepted	dgpstimeout delay
131	SETRTCM16	Enter an ASCII text message to be sent out in the RTCM data stream	SETRTCM16 text
137	LOCKOUT	Prevent the receiver from using a satellite by specifying its PRN	lockout prn
138	UNLOCKOUT	Reinstate a satellite in the solution computation	unlockout prn
139	UNLOCKOUTALL	Reinstate all previously locked out satellites	unlockoutall
142	DGPSEPHEMDELAY	DGPS ephemeris delay	dgpsephemdelay delay
144	DGPSTXID	DGPS transmit ID	dgpstxid type ID
160	DATUM	Choose a DATUM name type	datum datum
162	SETNAV	Set start and destination waypoints	setnav fromlat fromlon tolat tolon track offset from-point to-point
173	POSAVE	Implement position averaging for base station	posave[state] maxtime [maxhstd [maxvstd]]
177	SEND	Send an ASCII message to any of the communications ports	send port data
178	SENDHEX	Send non-printable characters in hexadecimal pairs	sendhex port length data
180	MAGVAR	Set magnetic variation correction	magvar type [correction [stddev]]
182	RTKBASELINE	Initialize RTK with a static baseline	rtkbaseline type [par1 par2 par3 [2sigma]]
183	RTKDYNAMICS	Set the RTK dynamics mode	rtkdynamics mode

Continued on Page 37

Message ID	Command	Description	Syntax
184	RTKSOLUTION	Set RTK carrier phase ambiguity type (Float or Fixed) or disable	rtksolution type
197	NVMRESTORE	Restore NVM data after a failure in NVM	nvmrestore
214	UNDULATION	Choose undulation	undulation option [separation]
230	EXTERNALCLOCK	Set external clock parameters	externalclock clocktype [freq] [h0 [h1 [h2]]]
232	FREQUENCYOUT	Sets the output pulse train available on VARF.	frequencyout [switch] [pulsewidth] [period]
258	DYNAMICS	Tune receiver parameters	dynamics dynamics
269	CSMOOTH	Set carrier smoothing	csmooth L1time [L2time]
377	SETAPPROXPOS	Set an approximate position	setapproxpos lat lon height
429	ADJUST1PPS	Adjust the receiver clock	adjust1pps mode [period] [offset]
430	CLOCKCALIBRATE	Adjust the control parameters of the clock steering loop	clockcalibrate mode [period] [width] [slope] [bandwidth]
431	COMCONTROL	Control the hardware control lines of the RS232 ports	comcontrol port signal control
729	ASSIGNLBAND	Set L-Band satellite communication parameters	assignlband mode freq baud
493	PSRDIFFSOURCE	Set the pseudorange correction source	psrdiffsource type ID
494	RTKSOURCE	Set the RTK correction source	rtksource type ID
505	WAASECUTOFF	Set SBAS satellite elevation cut-off	waasecutoff angle
596	CLOCKOFFSET	Adjust for antenna RF cable delay	clockoffset offset
601	PASSTOPASSMODE	Enable/disable solution smoothing modes	passtopassmode switch [measmth] [corsmth] [dwt] [dwtscale]
612	POSTIMEOUT	Sets the position time out	postimeout sec
613	PPSCONTROL	Control the PPS output	ppscontrol switch [polarity] [rate]
614	MARKCONTROL	Control the processing of the mark inputs	markcontrol signal switch [polarity] [timebias [timeguard]]
652	SBASCONTROL	Set SBAS test mode and PRN	sbascontrol keyword [prn] [testmode]
691	GGAQUALITY	Customize the GPGGA GPS quality indicator	#entries [pos type1][qual1] [pos type2] [qual2]...

Continued on Page 38

Message ID	Command	Description	Syntax
749	UTMZONE	Set UTM parameters	utmzone command parameter
761	FIXPOSDATUM	Set the position through a specified datum	position datum [lat [lon [height]]]
763	MOVINGBASE-STATION	Set ability to use a moving base station position	movingbasestation switch
780	HPSTATICINIT	Set static initialization of OmniSTAR HP	hpstaticinit switch
782	HPSEED	Specify the seed position for OmniSTAR HP	hpseed mode lat lon hgt lats lons hghts datum undulation
783	USEREXPDATUM	Set custom expanded datum	userexpdatum semimajor flattening dx dy dz rx ry rz scale xvel yvel zvel xrvel yrvel zrvel scalev refdate

When the receiver is first powered up, or after an FRESET command, all commands will revert to the factory default settings. The SAVECONFIG command can be used to modify the power-on defaults. Use the RXCONFIG log to determine command and log settings.

Ensure that all windows, other than the Console window, are closed in GPSolution before using the SAVECONFIG command.

-
- FRESET STANDARD causes all previously stored user configurations saved to non-volatile memory to be erased (including Saved Config, Saved Almanac, Saved Ephemeris, and L-Band-related data, excluding subscription information).
-

2.4 MiLLennium GPSCard Compatibility

Table 11: OEM4 Family Command Comparison

MiLLennium Command	Comparable OEM4 Family Command
ACCEPT	INTERFACEMODE
ANTENNAPOWER	ANTENNAPOWER
ASSIGN	ASSIGN
CLOCKADJUST	CLOCKADJUST
COMn	COM
COMn_DTR	COMCONTROL
COMn_RTS	COMCONTROL
CONFIG	Not currently supported.
CRESET	FRESET
CSMOOTH	CSMOOTH
DATUM	DATUM
DGPSTIMEOUT	DGPSTIMEOUT and DGPSEPHEMDELAY
DIFF_PROTOCOL	Not currently supported.
DYNAMICS	DYNAMICS
ECUTOFF	ECUTOFF
EXTERNALCLOCK	EXTERNALCLOCK
FIX HEIGHT	FIX HEIGHT
FIX POSITION	FIX POSITION
FREQUENCY_OUT	FREQUENCYOUT
FRESET	FRESET
HELP or ?	Not currently supported.
IONOMODEL	Not currently supported
LOCKOUT	LOCKOUT
LOG	LOG
MAGVAR	MAGVAR
MESSAGES	INTERFACEMODE
POSAVE	POSAVE
RESET	RESET
RESETHEALTH	Not currently supported.
RESETHEALTHALL	Not currently supported.
RINEX	Not currently supported.
RTCM16T	SETRTCM16
RTCMRULE	Not currently supported.
RTKMODE	RTKBASELINE, RTKCOMMAND, RTKDYNAMICS, RTKELEV MASK, RTKSOLUTION and RTKSVENTRIES
SAVEALMA	See the FRESET command on <i>Page 83</i> .
SAVECONFIG	SAVECONFIG
SEND	SEND
SENDHEX	SENDHEX
SETDGPSID	DGPSTXID, PSRDIFFSOURCE and RTKSOURCE
SETHEALTH	Not currently supported.
SETL1OFFSET	Not currently supported.
SETNAV	SETNAV
SETTIMESYNC	ADJUST1PPS
UNASSIGN	UNASSIGN
UNASSIGNALL	UNASSIGNALL
UNDULATION	UNDULATION
UNFIX	FIX NONE
UNLOCKOUT	UNLOCKOUT
UNLOCKOUTALL	UNLOCKOUTALL
UNLOG	UNLOG
UNLOGALL	UNLOGALL
USERDATUM	USERDATUM
VERSION	See the VERSION log on <i>Page 313</i>
WAASCORRECTION	SBASCONTROL

2.5 Factory Defaults

When the receiver is first powered up, or after a FRESET command (see *Page 81*), all commands revert to their factory default settings. When you use a command without specifying its optional parameters, it may have a different command default than the factory default. The SAVECONFIG command (see *Page 115*) can be used to save these defaults. Use the RXCONFIG log (see *Page 297*) to reference many command and log settings.

The factory defaults are:

```

ANTENNAPOWER ON
ASSIGNLBAND OMNISTAR 1536782 1200
CLOCKADJUST ENABLE
CLOCKOFFSET 0
COM COM1 9600 N 8 1 N OFF ON
COM COM2 9600 N 8 1 N OFF ON
COM COM3 9600 N 8 1 N OFF ON
COMCONTROL COM1 RTS DEFAULT
COMCONTROL COM2 RTS DEFAULT
COMCONTROL COM3 RTS DEFAULT
CSMOOTH 100 100
DATUM WGS84
DGPSEPHEMDELAY 120
DGPSTIMEOUT 300
DGPSTXID AUTO "ANY"
DYNAMICS AIR
ECUTOFF 5.0
EXTERNALCLOCK DISABLE
FIX NONE
FIXPOSDATUM NONE
FREQUENCYOUT DISABLE
HPSEED RESET
HPSTATICINIT DISABLE
INTERFACEMODE COM1 NOVATEL NOVATEL ON
INTERFACEMODE COM2 NOVATEL NOVATEL ON
INTERFACEMODE COM3 NOVATEL NOVATEL ON
INTERFACEMODE USB1 NOVATEL NOVATEL ON
INTERFACEMODE USB2 NOVATEL NOVATEL ON
INTERFACEMODE USB3 NOVATEL NOVATEL ON
LOG COM1 RXSTATUSEVENTA ONNEW 0 0 HOLD
LOG COM2 RXSTATUSEVENTA ONNEW 0 0 HOLD
LOG COM3 RXSTATUSEVENTA ONNEW 0 0 HOLD
LOG USB1 RXSTATUSEVENTA ONNEW 0 0 HOLD
LOG USB2 RXSTATUSEVENTA ONNEW 0 0 HOLD
LOG USB3 RXSTATUSEVENTA ONNEW 0 0 HOLD
MAGVAR CORRECTION 0 0
MARKCONTROL MARK1 ENABLE NEGATIVE 0 0

```

```
MARKCONTROL MARK2 ENABLE NEGATIVE 0 0
MOVINGBASESTATION DISABLE
POSAVE OFF
POSTIMEOUT 600
PPSCONTROL ENABLE NEGATIVE 1.0 0
PSRDIFFSOURCE AUTO "ANY"
RTKCOMMAND USE_DEFAULTS
RTKSOLUTION AUTO
RTKBASELINE UNKNOWN 0 0 0 0
RTKDYNAMICS DYNAMIC
RTKELEVMASK AUTO 0
RTKSVENTRIES 12
RTKSOURCE AUTO "ANY"
SBASCONTROL DISABLE AUTO 0 NONE
SETNAV 90.0 0.0 90.0 0.0 0.0 0.0 from to
STATUSCONFIG PRIORITY STATUS 0
STATUSCONFIG PRIORITY AUX1 0x00000008
STATUSCONFIG PRIORITY AUX2 0
STATUSCONFIG SET STATUS 0x00000000
STATUSCONFIG SET AUX1 0
STATUSCONFIG SET AUX2 0
STATUSCONFIG CLEAR STATUS 0x00000000
STATUSCONFIG CLEAR AUX1 0
STATUSCONFIG CLEAR AUX2 0
UNDULATION TABLE 0
USERDATUM 6378137.0 298.2572235628 0.0 0.0 0.0 0.0 0.0 0.0 0.0 0.0
USEREXPDATUM 6378137.0 298.25722356280 0.0 0.0 0.0 0.0 0.0 0.0 0.0
0.0 0.0 0.0 0.0 0.0 0.0 0.0 0.0 0.0
UTMZONE AUTO 0
WAASECUTOFF -5.000000000
```

2.6 Command Reference

When you use a command without specifying its optional parameters, it may have a different command default than the factory default. See *Section 2.5* starting on *Page 40* for the factory default settings and the individual commands in the sections that follow for their command defaults.

2.6.1 ADJUST1PPS Adjust the receiver clock

This command is used to adjust the receiver clock or as part of the procedure to transfer time between receivers. The number of pulses per second (PPS) is always set to 1 Hz with this command. It is typically used when the receiver is not adjusting its own clock and is using an external reference frequency.

To disable the automatic adjustment of the clock, refer to the `CLOCKADJUST` command on *Page 55*. To configure the receiver to use an external reference oscillator, see the `EXTERNALCLOCK` command on *Page 74*.

The `ADJUST1PPS` command can be used to:

- Manually shift the phase of the clock
- Adjust the phase of the clock so that the output 1PPS signal matches an external signal
- Set the receiver clock close to that of another GPS receiver
- Set the receiver clock exactly in phase of another GPS receiver

-
- ☒ 1. The resolution of the clock synchronization is 50 ns.
 - 2. To adjust the 1PPS output when the receiver's internal clock is being used and the `CLOCKADJUST` command is enabled, use the `CLOCKOFFSET` command on *Page 58*.
 - 3. If the 1PPS rate is adjusted, the new rate does not start until the next second begins.
-

Figure 1 shows the 1PPS alignment between a Fine and a Cold Clock receiver. See also the `TIMESYNC` log on *Page 310* and the *Transfer Time Between Receivers* section in *Volume 1* of this manual set.

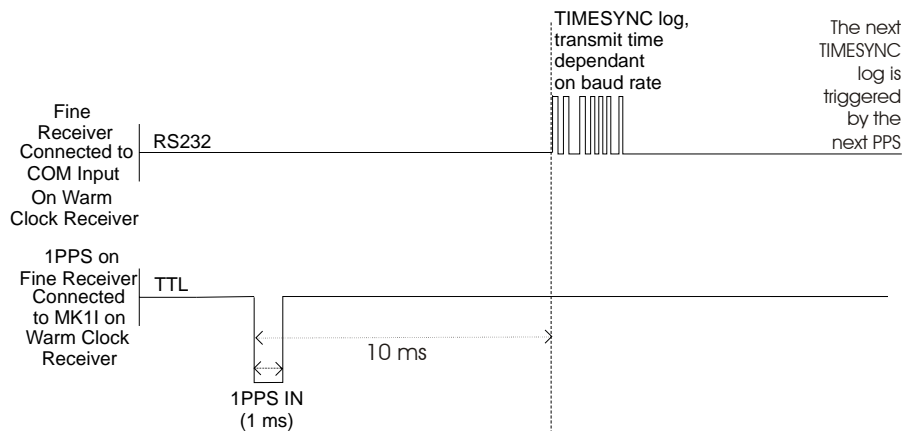

Figure 1: 1PPS Alignment

1PPS Output

The 1PPS is obtained from different receivers in different ways.

If you are using a:

Bare Card	The 1PPS output strobe is on pin# 7 of the OEM4-G2 or on pin# 4 of the OEM4-G2L.
ProPak-G2 <i>plus</i> or DL-4 <i>plus</i>	A DB9F connector on the back of the enclosure provides external access to various I/O strobes to the internal OEM4-G2 card. This includes the 1PPS output signal, which is accessible on pin# 2 of the DB9F connector.
ProPak-LB <i>plus</i>	The 1PPS output signal is accessible on pin# 1 of the COM1 SwitchCraft connector.
FlexPak-G2L	The 1PPS output signal is accessible on pin# 10 of the COM1 Deutsch connector.

Alternatively, the 1PPS signal can be set up to be output on the RTS signal of COM1, COM2, or COM3, or the DTR signal of COM2 using the COMCONTROL command, see *Page 61*. The accuracy of the 1PPS is less using this method, but may be more convenient in some circumstances.

☒ COM3 is not available on some enclosure configurations, nor the OEM4-G2L card. The DTR signal is not available on the ProPak-G2 enclosure.

To find out the time of the last 1PPS output signal use the TIMEA/B output message, see *Page 309*, which can be output serially on any available COM port, for example:

```
LOG COM1 TIMEA ONTIME 1
```

Abbreviated ASCII Syntax:

Message ID: 429

ADJUSTIPPS mode [period] [offset]

Field	Field Type	ASCII Value	Binary Value	Description	Binary Format	Binary Bytes	Binary Offset
1	header	-	-	This field contains the command name or the message header depending on whether the command is abbreviated ASCII, ASCII or binary, respectively.	-	H	0
2	mode	OFF	0	Disables ADJUSTIPPS (default).	Enum	4	H
		MANUAL	1	Immediately shifts the receivers time by the offset field in ns. The period field has no effect in this mode. This command does not affect the clock state			
		MARK ^a	2	Shifts the receiver time to align its 1PPS with the signal received in the MK11 port adjusted by the offset field in ns. The effective shift range is ± 0.5 s.			
		MARKWITHTIME ^b	3	Shifts the receiver time to align its 1PPS with the signal received in the MK11 port adjusted by the offset field in ns, and sets the receiver Time of Week (TOW) and week number, to that embedded in a received TIMESYNC log, see <i>Page 310</i> . It also sets the receiver Time Status to that embedded in the TIMESYNC log, which must have arrived between 800 and 1000 ms prior to the MK11 event (presumably the 1PPS from the master), or it will be rejected as an invalid message.			
		TIME	4	If the receiver clock is not at least COARSE adjusted, this command enables the receiver to COARSE adjust its time upon receiving a valid TIMESYNC log in any of the ports. The clock state embedded in the TIMESYNC log must be at least FINE or FINESTEERING before it will be considered. The receiver does not use the MK11 event in this mode.			

Continued on Page 45

3	period	ONCE	0	The time is synchronized only once (default). The ADJUST1PPS command must be re-issued if another synchronization is required.	Enum	4	H+4
		CONTINUOUS	1	The time is continuously monitored and the receiver clock is corrected if an offset of more than 50 ns is detected.			
4	offset	-2147483648 to +2147483647		Allows the operator to shift the slave clock in 50 ns increments. In MANUAL mode, this command will apply an immediate shift of this offset in ns to the receiver clock. In MARK and MARKWITHTIME mode, this offset will shift the receiver clock with respect to the time of arrival of the MK1I event. If this offset is zero the slave will align its 1PPS to that of the signal received in its MK1I port. For example, if this value was set to 50, then the slave would set its 1PPS 50 ns ahead of the input signal and if this value was set to -100 then the slave would set its clock to 100 ns behind the input signal. Typically this offset is	Long	4	H+8

- a. Only the MK1I input can be used to synchronize the 1PPS signal. Synchronization cannot be done using the MK2I input offered on some receivers.
- b. It is presumed that the TIMESYNC log, see *Page 310*, was issued by a Master GPS receiver within 1000 ms, but not less than 800 ms, of the last 1PPS event, see *Figure 1, 1PPS Alignment on Page 42*. Refer also to the *Transfer Time Between Receivers* section in *Volume 1* of this manual set.

ASCII Example:

ADJUST1PPS MARK CONTINUOUS 240

2.6.2 ANTENNAPOWER Control power to the antenna

This command enables or disables the supply of electrical power from the internal (see *Volume 1* of this manual set for information on supplying power to the antenna) power source of the receiver to the low-noise amplifier (LNA) of an active antenna.

There are several bits in the Receiver Status (see *Table 81, Receiver Status on Page 303*) that pertain to the antenna. These bits indicate whether the antenna is powered (internally or externally) and whether it is open circuited or short circuited.

On startup, the ANTENNAPOWER is set to ON.

Abbreviated ASCII Syntax:

Message ID: 98

ANTENNAPOWER flag

Field	Field Type	ASCII Value	Binary Value	Description	Binary Format	Binary Bytes	Binary Offset
1	header	-	-	This field contains the command name or the message header depending on whether the command is abbreviated ASCII, ASCII or binary, respectively.	-	H	0
2	flag	OFF	0	Disables internal powering of antenna.	Enum	4	H
		ON	1	Enables internal powering of antenna.			

ASCII Example:

```
ANTENNAPOWER ON
```

2.6.3 ASSIGN Assign a channel to a PRN

☒ The ASSIGN command should only be used by advanced users of GPS.

This command may be used to aid in the initial acquisition of a satellite by allowing you to override the automatic satellite/channel assignment and reacquisition processes with manual instructions. The command specifies that the indicated tracking channel search for a specified satellite at a specified Doppler frequency within a specified Doppler window.

The instruction remains in effect for the specified SV channel and PRN, even if the assigned satellite subsequently sets. If the satellite Doppler offset of the assigned SV channel exceeds that specified by the *window* parameter of the ASSIGN command, the satellite may never be acquired or re-acquired. If a PRN has been assigned to a channel and the channel is currently tracking that satellite, when the channel is set to *AUTO* tracking, the channel will immediately idle and return to automatic mode.

To cancel the effects of *ASSIGN*, you must issue one of the following:

- The *ASSIGN* command with the *state* set to *AUTO*
- The *UNASSIGN* command
- The *UNASSIGNALL* command

These will return SV channel control to the automatic search engine immediately.

-
- ☒ 1. Assigning a SV channel will set the forced assignment bit in the channel tracking status field which is reported in the RANGE and TRACKSTAT logs
2. Assigning a PRN to a SV channel does not remove the PRN from the search space of the automatic searcher; only the SV channel is removed (that is, the searcher may search and lock onto this PRN on another channel). The automatic searcher only searches for PRNs 1 to 32 for GPS channels and PRNs 120 to 138 for SBAS channels.
-

Table 12: Channel State

Binary	ASCII	Description
0	IDLE	Set the SV channel to not track any satellites
1	ACTIVE	Set the SV channel active (default)
2	AUTO	Tell the receiver to automatically assign PRN codes to channels

Abbreviated ASCII Syntax:

Message ID: 27

ASSIGN channel [state] [prn [Doppler [window]]]

Field	Field Type	ASCII Value	Binary Value	Description	Binary Format	Binary Bytes	Binary Offset
1	header	-	-	This field contains the command name or the message header depending on whether the command is abbreviated ASCII, ASCII or binary, respectively (see <i>1.1, Message Types on Page 13</i>).	-	H	0
2	channel	0 to 11		Desired SV channel number from 0 to 11 inclusive (where channel 0 is the first SV channel and channel 11 is the last).	ULong	4	H
3	state	See Table 12, Channel State on Page 47		Set the SV channel state.	Enum	4	H+4
4	prn	1 to 32, 120 to 138		Optional satellite PRN code from 1-32 for GPS channels and 120-138 for SBAS channels. If not included in the command line, the state parameter must be set to IDLE.	Long	4	H+8
5	Doppler	-100 000 to 100 000 Hz		Current Doppler offset of the satellite Note: Satellite motion, receiver antenna motion and receiver clock frequency error must be included in the calculation of Doppler frequency. (default = 0)	Long	4	H+12
6	window	0 to 10 000 Hz		Error or uncertainty in the Doppler estimate above. Note: This is a \pm value. Example: 500 for \pm 500 Hz. (default = 4 500)	ULong	4	H+16

ASCII Example 1:

```
ASSIGN 0,ACTIVE,29,0,2000
```

In example 1, the first SV channel is acquiring satellite PRN 29 in a range from -2000 Hz to 2000 Hz until the satellite signal has been detected.

ASCII Example 2:

```
ASSIGN 11,28,-250,0
```

SV channel 11 is acquiring satellite PRN 28 at an offset of -250 Hz only.

ASCII Example 3:

```
ASSIGNA 11, IDLE
```

SV channel 11 is idled and will not attempt to search for satellites.

2.6.4 ASSIGNALL Assign all channels to a PRN

☒ The ASSIGNALL command should only be used by advanced users of GPS.

This command allows you to override the automatic satellite/channel assignment and reacquisition processes for all receiver channels with manual instructions. This command works the same way as ASSIGN except that it affects all SV channels.

Abbreviated ASCII Syntax:

Message ID: 28

ASSIGNALL [system][state][prn [Doppler [window]]]

Field	Field Type	ASCII Value	Binary Value	Description	Binary Format	Binary Bytes	Binary Offset
1	header	-	-	This field contains the command name or the message header depending on whether the command is abbreviated ASCII, ASCII or binary, respectively.	-	H	0
2	system	See Table 13		System that SV channel is tracking.	Enum	4	H
3	state	See Table 12, Channel State on Page 47		Set the SV channel state.	Enum	4	H+4
4	prn	1 to 37, 120-138		Optional satellite PRN code from 1-37 for GPS channels and 120-138 for SBAS channels. If not included in the command line, the state parameter must be set to idle.	Long	4	H+8
5	Doppler	-100 000 to 100 000 Hz		Current Doppler offset of the satellite Note: Satellite motion, receiver antenna motion and receiver clock frequency error must be included in the calculation of Doppler frequency. (default = 0)	Long	4	H+12
6	window	0 to 10 000 Hz		Error or uncertainty in the Doppler estimate above. This is a \pm value (for example, 500 for \pm 500 Hz). (default =4500)	ULong	4	H+16

Table 13: Channel System

Binary	ASCII	Description
0	GPSL1	GPS L1 dedicated SV channels only.
1	GPSL1L2	GPS L1 and L2 dedicated SV channels only.
2	NONE	No dedicated SV channels.
3	ALL	All channels (default).
4	WAASL1	SBAS SV channels only.

ASCII Example 1:

```
ASSIGNALL GPSL1,ACTIVE,29,0,2000
```

In example 1, all GPS L1 dedicated SV channels are set to active and trying to acquire PRN 29 in a range from -2000 Hz to 2000 Hz until the satellite signal has been detected.

ASCII Example 2:

```
ASSIGNALL GPSL1L2,28,-250,0
```

All L1 and L2 dedicated SV channels are trying to acquire satellite PRN 28 at -250 Hz only.

ASCII Example 3:

```
ASSIGNALL GPSL1, IDLE
```

All L1 only dedicated SV channels are idled and are not attempting to search for satellites.

2.6.5 ASSIGNLBAND Set L-band satellite communication parameters

You must use this command to ensure that the receiver searches for a specified L-Band satellite at a specified frequency with a specified baud rate. The factory parameter defaults are [OMNISTAR 1536782 1200].

-
- ☒ 1. In addition to a NovAtel receiver with L-Band capability, a subscription to the OmniSTAR, or use of the free CDGPS, service is required. Contact NovAtel for details. Contact information may be found on the back of this manual set or you can refer to the *Customer Service* section in *Volume 1* of this manual set.
 - 2. The frequency assignment, field #3 below, can be made in kHz or Hz. For example:
 ASSIGNLBAND OMNISTAR 1535152500 1200
 A value entered in Hz is rounded to the nearest 500 Hz.
 - 3. The NAD83 (CSRS) datum is available to CDGPS users. The receiver automatically transforms the CDGPS computed coordinates into WGS84 (the default datum of the receiver). Alternatively, select any datum, including CSRS, for a specified coordinate system output. See also *Table 20, Datum Transformation Parameters on Page 65*.
 - 4. The ASSIGNNOMNI command is still available to OmniSTAR users but will be made obsolete in a future firmware release. Please use the ASSIGNLBAND command instead.
-

Abbreviated ASCII Syntax:

Message ID: 729

ASSIGNLBAND mode freq baud

Field	Field Type	ASCII Value	Binary Value	Description	Binary Format	Binary Bytes	Binary Offset
1	header	-	-	This field contains the command name or the message header depending on whether the command is abbreviated ASCII, ASCII or binary, respectively (see <i>1.1, Message Types on Page 13</i>).	-	H	0
2	mode	See <i>Table 14</i>		Set the mode and enter specific frequency and baud rate values.	Enum	4	H
3	freq	1525000 to 1560000 or 1525000000 to 1560000000		L-Band service beam frequency of satellite (Hz or kHz). See also <i>Beam Frequencies on Page 52</i> .	Ulong	4	H+4
4	baud	300, 600, 1200, 2400 or 4800		Data rate for communication with L-Band satellite.	Ulong	4	H+8

ASCII Example 1:

```
assignlband cdgps 1547547 4800
```

ASCII Example 2:

```
assignlband omnistar 153678200 1200
```

Table 14: L-Band Mode

Binary	ASCII	Description
0	Reserved	
1	OMNISTAR	When you select OmniSTAR, enter a dedicated frequency and baud rate
2	CDGPS	When you select CDGPS, enter a dedicated frequency and baud rate

Beam Frequencies

You can switch between OmniSTAR VBS and CDGPS by using the following commands:

Use CDGPS

```
ASSIGNLBAND CDGPS <freq> 4800
PSRDIFFSOURCE CDGPS
```

Use OmniStar VBS

```
ASSIGNLBAND OMNISTAR <freq> 1200
PSRDIFFSOURCE OMNISTAR
```

Where <freq> is determined for CDGPS or OmniStar as follows:

- CDGPS beam frequency chart:
 - East 1547646 or 1547646000
 - East-Central 1557897 or 1557897000
 - West-Central 1557571 or 1557571000
 - West 1547547 or 1547547000
- The OmniStar beam frequency chart can be found at http://www.omnistar.com/setup_osrc.html.

For example:

Eastern US (Coverage is Northern Canada to southern Mexico) 1530359 or 1530359000

-
- ☒ OmniSTAR has changed channels (frequencies) on the AMSC Satellite that broadcasts OmniSTAR corrections for North America. NovAtel receivers do not need a firmware change. To change frequencies, connect your receiver and issue an ASSIGNLBAND command. For example, the Western Beam frequency as stated on Omnistar's website is 1536.7820 MHz. Input into the receiver: `assignlband omnistar 1536782 1200`
-

2.6.6 AUTH Add authorization code for new model

This command is used to add or remove authorization codes from the receiver. Authorization codes are used to authorize models of software for a receiver. The receiver is capable of keeping track of five authorization codes at one time. The MODEL command can then be used to switch between authorized models. The VALIDMODELS log will list the current available models in the receiver. This simplifies the use of multiple software models on the same receiver.

If there is more than one valid model in the receiver, the receiver will either use the model of the last auth code entered via the AUTH command or the model that was selected by the MODEL command, whichever was done last. Both the AUTH and MODEL commands cause a reset automatically.

-
- ☒ Authorization codes are firmware version specific. If the receiver firmware is updated, it is necessary to acquire new authorization codes for the required models. If you wish to update the firmware in the receiver, please contact NovAtel Customer Service.
-

WARNING!: Removing an authorization code will cause the receiver to permanently lose this information.

Abbreviated ASCII Syntax:

Message ID: 49

AUTH [state] part1 part2 part3 part4 part5 model model [date]

Field	Field Type	ASCII Value	Binary Value	Description	Binary Format	Binary Bytes	Binary Offset
1	header	-	-	This field contains the command name or the message header depending on whether the command is abbreviated ASCII, ASCII or binary, respectively.	-	H	0
2	state	REMOVE	0	Remove the authcode from the system.	Enum	4	H
		ADD	1	Add the authcode to the system. (default)			
3	part1	4 digit hexadecimal (0-FFFF)		Authorization code section 1.	ULong	4	H+4
4	part2	4 digit hexadecimal (0-FFFF)		Authorization code section 2.	ULong	4	H+8
5	part3	4 digit hexadecimal (0-FFFF)		Authorization code section 3.	ULong	4	H+12
6	part4	4 digit hexadecimal (0-FFFF)		Authorization code section 4.	ULong	4	H+16
7	part5	4 digit hexadecimal (0-FFFF)		Authorization code section 5.	ULong	4	H+20
8	model	Alpha numeric	Null terminated	Model name of the receiver	String [max. 16]	Variable ^a	Variable
9	date	Numeric	Null terminated	Expiry date entered as yymmdd in decimal.	String [max. 7]	Variable ^a	Variable

a. In the binary log case additional bytes of padding are added to maintain 4 byte alignment

Input Examples:

```
AUTH ADD 1234 5678 9ABC DEF0 1234 OEM4L1L2 990131
```

```
AUTH 1234 5678 9ABC DEF0 1234 OEM4L1L2
```

2.6.7 CLOCKADJUST Enable clock adjustments

All oscillators have some inherent drift. By default the receiver attempts to steer the receiver’s clock to accurately match GPS time. If for some reason this is not desired, this behavior can be disabled using the CLOCKADJUST command. The TIME log can then be used to monitor clock drift.

-
- ☒ 1. The CLOCKADJUST command should only be used by advanced users of GPS.
 - 2. If the CLOCKADJUST command is ENABLED, and the receiver is configured to use an external reference frequency (set in the EXTERNALCLOCK command, see *Page 74*, for an external clock - TCXO, OCXO, RUBIDIUM, CESIUM, or USER), then the clock steering process will take over the VARF output pins and may conflict with a previously entered FREQUENCYOUT command, see *Page 81*.
 - 3. When disabled, the range measurement bias errors will continue to accumulate with clock drift.
 - 4. Pseudorange, carrier phase and Doppler measurements may jump if the CLOCKADJUST mode is altered while the receiver is tracking.
 - 5. When disabled, the time reported on all logs may be offset from GPS time. The 1PPS output may also be offset. The amount of this offset may be determined from the TIME log, see *Page 308*.
 - 6. A discussion on GPS time may be found in *Section 1.3, GPS Time Status on Page 21*.
-

Abbreviated ASCII Syntax:

Message ID: 15

CLOCKADJUST switch

Field	Field Type	ASCII Value	Binary Value	Description	Binary Format	Binary Bytes	Binary Offset
1	header	-	-	This field contains the command name or the message header depending on whether the command is abbreviated ASCII, ASCII or binary, respectively.	-	H	0
2	switch	DISABLE	0	Disallow adjustment of internal clock.	Enum	4	H
		ENABLE	1	Allow adjustment of internal clock.			

ASCII Example:

CLOCKADJUST DISABLE

2.6.8 CLOCKCALIBRATE Adjust clock steering parameters

This command is used to adjust the control parameters of the clock steering loop. The receiver must be enabled for clock steering before these values can take effect. Refer to the CLOCKADJUST command, see *Page 55*, to enable or disable this feature. The receiver by default steers its INTERNAL VCTCXO but can be commanded to control an EXTERNAL reference oscillator. Use the EXTERNALCLOCK command, see *Page 74*, to configure the receiver to use an external reference oscillator. If the receiver is configured for an external reference oscillator and configured to adjust its clock, then the clock steering loop will attempt to steer the external reference oscillator through the use of the VARF signal. Note that the clock steering control process will conflict with the manual FREQUENCYOUT command, see *Page 81*. It is expected that the VARF signal is used to provide a stable reference voltage by the use of a filtered charge pump type circuit (not supplied).

To disable the clock steering process, issue the CLOCKADJUST DISABLE command.

The current values used by the clock steering process are listed in the CLOCKSTEERING log, see *Page 175*.

-
- The values entered using the CLOCKCALIBRATE command will be saved to non-volatile memory (NVM). To restore the values to their defaults, the FRESET CLKCALIBRATION command must be used. See *Section 2.6.24 on Page 83* for more details.
-

Abbreviated ASCII Syntax:

Message ID: 430

CLOCKCALIBRATE mode [period] [width] [slope] [bandwidth]

Field	Field Type	ASCII Value	Binary Value	Description	Binary Format	Binary Bytes	Binary Offset
1	header	-	-	This field contains the command name or the message header depending on whether the command is abbreviated ASCII, ASCII or binary, respectively.	-	H	0
2	mode	SET	0	Sets the period, pulsewidth, slope, and bandwidth values into NVM for the currently selected steered oscillator (INTERNAL or EXTERNAL).	Enum	4	H
		AUTO	1	Forces the receiver to do a clock steering calibration to measure the slope (change in clock drift rate with a 1 bit change in pulse width), and required pulsewidth, to zero the clock drift rate. After the calibration, these values along with the period and bandwidth are entered into NVM and will then be used from this point forward on the selected oscillator.			
		OFF	2	Terminates a calibration process currently underway.			

Continued on Page 57

3	period	0 to 262144	Signal period in 25 ns steps. Frequency Output = 40,000,000 / Period. (default = 0)	Ulong	4	H+4
4	pulsewidth	The valid range for this parameter is 10% to 90% of the period.	Sets the initial pulse width that should provide a near zero drift rate from the selected oscillator being steered. The valid range for this parameter is 10% to 90% of the period. The default value is 2000. If this value is not known, (in the case of a new external oscillator) then it should be set to ½ the period and the mode should be set to AUTO to force a calibration.	Ulong	4	H+8
5	slope		This value should correspond to how much the clock drift will change with a 1 bit change in the pulsewidth m/s/bit. The default values for the slope used for the INTERNAL and EXTERNAL clocks is -2.0 and -0.01 respectively. If this value is not known, then its value should be set to 1.0 and the mode should be set to AUTO to force a calibration. Once the calibration process is complete and using a slope value of 1.0, the receiver should be recalibrated using the measured slope and pulsewidth values (Fields #6 and #4 of the CLOCKSTEERING log, see <i>Page 175</i>). This process should be repeated until the measured slope value remains constant (less than a 5% change).	Float	4	H+12
6	bandwidth		This is the value used to control the smoothness of the clock steering process. Smaller values will result in slower and smoother changes to the receiver clock. Larger values will result in faster responses to changes in oscillator frequency and faster startup clock pull-in. The default values are 0.03 and 0.001 Hz respectively for the INTERNAL and EXTERNAL clocks.	Float	4	H+16

ASCII Example:

CLOCKCALIBRATE AUTO

2.6.9 CLOCKOFFSET Adjust for delay in 1PPS output

This command can be used to remove a delay in the PPS output. The PPS signal is delayed from the actual measurement time due to two major factors:

- A delay in the signal path from the antenna to the receiver
- An intrinsic delay through the RF and digital sections of the receiver

The second delay is automatically accounted for by the receiver using a nominal value determined for each receiver type. However, since the delay from the antenna to the receiver cannot be determined by the receiver, an adjustment cannot automatically be made. The CLOCKOFFSET command can be used to adjust for this delay. For example, for a cable with a delay of 10 ns, the offset can be set to -10 to remove the delay from the PPS output.

Abbreviated ASCII Syntax:

Message ID: 569

CLOCKOFFSET offset

Field	Field Type	ASCII Value	Binary Value	Description	Binary Format	Binary Bytes	Binary Offset
1	header	-	-	This field contains the command name or the message header depending on whether the command is abbreviated ASCII, ASCII or binary, respectively (see <i>1.1, Message Types on Page 13</i>).	-	H	0
2	offset	-200 to +200		Specifies the offset in nanoseconds.	Long	4	H

ASCII Example:

```
CLOCKOFFSET -15
```

2.6.10 COM COM port configuration control

This command permits you to configure the receiver’s asynchronous serial port communications drivers.

The current COM port configuration can be reset to its default state at any time by sending it two hardware break signals of 250 milliseconds each, spaced by fifteen hundred milliseconds (1.5 seconds) with a pause of at least 250 milliseconds following the second break. This will:

- Stop the logging of data on the current port (see UNLOGALL on Page 132)
- Clear the transmit and receive buffers on the current port
- Return the current port to its default settings (see Page 40 for details)
- Set the interface mode to NovAtel for both input and output (see the INTERFACEMODE command on Page 87)

See also Section 2.5, *Factory Defaults on Page 40* for a description of the factory defaults, and the COMCONFIG log on Page 185.

☒ The COMCONTROL command, see Page 61, may conflict with handshaking of the selected COM port. If handshaking is enabled, then unexpected results may occur.

Abbreviated ASCII Syntax:

Message ID: 4

COM [port] bps [parity[databits[stopbits[handshake[echo[break]]]]]]

Field	Field Type	ASCII Value	Binary Value	Description	Binary Format	Binary Bytes	Binary Offset
1	header	-	-	This field contains the command name or the message header depending on whether the command is abbreviated ASCII, ASCII or binary, respectively.	-	H	0
2	port	See Table 15, <i>COM Serial Port Identifiers on Page 60</i>		Port to configure. (default = THISPORT)	Enum	4	H
3	bps/ baud	300, 600, 900, 1200, 2400, 4800, 9600, 19200, 38400, 57600, 115200, or 230400		Communication baud rate (bps). Bauds of 460800 and 921600 are also available on COM1 of OEM4-G2-based products.	ULong	4	H+4
4	parity	See Table 16 on Page 60		Parity	Enum	4	H+8
5	databits	7 or 8		Number of data bits (default = 8).	ULong	4	H+12
6	stopbits	1 or 2		Number of stop bits (default = 1).	ULong	4	H+16
7	handshake	See Table 17 on Page 60		Handshaking	Enum	4	H+20
8	echo	OFF	0	No echo (default).	Enum	4	H+24
		ON	1	Transmit any input characters as they are received.			
9	break	OFF	0	Disable break detection	Enum	4	H+28
		ON	1	Enable break detection (default)			

ASCII Example:

COM COM1,57600,N,8,1,N,OFF,ON

Table 15: COM Serial Port Identifiers

Binary	ASCII	Description
1	COM1	COM port 1
2	COM2	COM port 2
3	COM3	COM port 3
6	THISPORT	The current COM port
8	ALL	All COM ports
9	XCOM1 ^a	Virtual COM1 port
10	XCOM2 ^a	Virtual COM2 port
13	USB1 ^b	USB port 1
14	USB2 ^b	USB port 2
15	USB3 ^b	USB port 3
16	AUX ^c	AUX port

- a. The XCOM1 and XCOM2 identifiers are not available with the COM command but may be used with other commands. For example, INTERFACEMODE on *Page 87* and LOG on *Page 90*.
- b. The only other field that applies when a USB port is selected is the echo field. Placeholder must be inserted for all other fields to use the echo field in this case.
- c. The AUX port is only available on OEM4-G2-based (hardware Rev. 3 and higher) and DL-4 products.

Table 16: Parity

Binary	ASCII	Description
0	N	No parity (default)
1	E	Even parity
2	O	Odd parity

Table 17: Handshaking

Binary	ASCII	Description
0	N	No handshaking (default)
1	XON	XON/XOFF software handshaking
2	CTS	CTS/RTS hardware handshaking

2.6.11 COMCONTROL Control the RS232 hardware control lines

This command is used to control the hardware control lines of the RS232 ports. The TOGGLEPPS mode of this command is typically used to supply a timing signal to a host PC computer by using the RTS or DTR lines. The accuracy of controlling the COM control signals is better than 900 μ s. The other modes are typically used to control custom peripheral devices. Also, it is possible to communicate with all three serial ports simultaneously using this command.

☒ If handshaking is disabled, any of these modes can be used without affecting regular RS232 communications through the selected COM port. However, if handshaking is enabled, it may conflict with handshaking of the selected COM port, causing unexpected results.

Abbreviated ASCII Syntax:

Message ID: 431

COMCONTROL port signal control

Field	Field Type	ASCII Value	Binary Value	Description	Binary Format	Binary Bytes	Binary Offset
1	header	-	-	This field contains the command name or the message header depending on whether the command is abbreviated ASCII, ASCII or binary, respectively.	-	H	0
2	port	COM1	1	RS232 port to control. Valid ports are COM1, COM2, COM3 and AUX. The AUX port is only available on OEM4-G2-based (hardware Rev. 3 and higher) and DL-4 products.	Enum	4	H
		COM2	2				
		COM3	3				
		AUX	16				
3	signal	RTS	0	COM signal to control. The controllable COM signals are RTS, DTR and TX. See also <i>Table 18, Tx and DTR Availability on Page 62</i>	Enum	4	H+4
		DTR	1				
		TX	2				
4	control	DEFAULT	0	Disables this command and returns the COM signal to its default state.	Enum	4	H+8
		FORCEHIGH	1	Immediately forces the signal high.			
		FORCELOW	2	Immediately forces the signal low.			
		TOGGLE	3	Immediately toggles the current state of the signal.			
		TOGGLEPPS	4	Toggles the state of the selected signal within 900 μ s after each 1PPS event. The state change of the signal will lag the 1PPS by an average value of 450 μ s. The delay of each pulse will vary by a uniformly random amount less than 900 μ s.			
		PULSEPPSLOW	5	Pulses the line low at a 1PPS event and to high 1 ms after it. Not for TX.			
		PULSEPPSHIGH	6	Pulses the line high for 1 ms at the time of a 1PPS event.			

Table 18: Tx and DTR Availability

	Tx available on:	DTR available on:
OEM4-G2L	COM1 and COM2	N/A
OEM4-G2	COM1, COM3 and AUX	COM2
OEM4 (obsolete)	COM1 and COM3	COM2

ASCII Example 1:

```
COM COM1 9600 N 8 1 N (to disable handshaking)
COMCONTROL COM1 RTS FORCELOW
COMCONTROL COM2 DTR TOGGLEPPS
```

ASCII Example 2:

```
COMCONTROL COM1 RTS TOGGLEPPS
COMCONTROL COM2 RTS TOGGLEPPS
COMCONTROL COM3 RTS TOGGLEPPS
```

ASCII Example 3:

OEM4-G2:

To set a break condition on AUX:

```
COMCONTROL AUX TX FORCELOW
```

A break condition remains in effect until it is cleared.

To clear a break condition on AUX:

```
COMCONTROL AUX TX DEFAULT
```

or

```
COMCONTROL AUX TX FORCEHIGH
```

-
- ☒ 1. The RTS line is available on all OEM4 family COM ports.
 - 2. The PULSEPPSLOW control type cannot be issued for a TX signal.
-

2.6.12 CSMOOTH Set carrier smoothing

This command sets the amount of carrier smoothing to be performed on the code measurements. An input value of 100 corresponds to approximately 100 seconds of smoothing. Upon issuing the command, the locktime for all tracking satellites is reset to zero. From this point each code smoothing filter is restarted. The user must wait for at least the length of smoothing time for the new smoothing constant to take full effect. The optimum setting for this command is dependent on your application.

Abbreviated ASCII Syntax:

Message ID: 269

CSMOOTH L1time [L2time]

Field	Field Type	ASCII Value	Binary Value	Description	Binary Format	Binary Bytes	Binary Offset
1	header	-	-	This field contains the command name or the message header depending on whether the command is abbreviated ASCII, ASCII or binary, respectively.	-	H	0
2	L1time	2-2000		L1 carrier smoothing time constant, in seconds.	Ulong	4	H
3	[L2time]	5-2000		L2 carrier smoothing time constant, in seconds. Default = 100.	Ulong	4	H+4

Abbreviated ASCII Example:

CSMOOTH 500

-
- ☒ 1. The CSMOOTH command should only be used by advanced GPS users. The shorter the carrier smoothing the more noise there will be. If you are at all unsure please call NovAtel Customer Service Department, see the *Customer Service* section at the start of *Volume 1* of this manual set.
 - 2. It may not be suitable for every GPS application. When using CSMOOTH in differential mode, the same setting should be used at both the base and rover station, if both the base and rover stations are using the same type of receiver (both OEM3 or both OEM4 family). However if the base and rover stations use different types of receivers (OEM3 and OEM4 family), it is recommended that the CSMOOTH command default value is used at each receiver.
-

2.6.13 DATUM Choose a datum name type

This command permits you to select the geodetic datum for operation of the receiver. If not set, the factory default value is WGS84. See the USERDATUM command for user definable datums. The datum you select causes all position solutions to be based on that datum.

The NAD83 (CSRS) datum is available to CDGPS users. The receiver automatically transforms the CDGPS computed coordinates into WGS84 (the default datum of the receiver). Alternatively, select any datum, including CSRS, for a specified coordinate system output.

The transformation for the WGS84 to Local used in the OEM4 family is the Bursa-Wolf transformation or reverse Helmert transformation. In the Helmert transformation, the rotation of a point is counterclockwise around the axes. In the Bursa-Wolf transformation, the rotation of a point is clockwise. Therefore, the reverse Helmert transformation is the same as the Bursa-Wolf.

See *Table 20* on *Page 65* for a complete listing of all available predefined datums.

Abbreviated ASCII Syntax:

Message ID: 160

DATUM datum

Field	Field Type	ASCII Value	Binary Value	Description	Binary Format	Binary Bytes	Binary Offset
1	header	-	-	This field contains the command name or the message header depending on whether the command is abbreviated ASCII, ASCII or binary, respectively.	-	H	0
2	datum	See <i>Table 20, Datum Transformation Parameters</i> on <i>Page 65</i>		User defined datum with parameters specified by the USERDATUM command	Enum	4	H

ASCII Example:

DATUM CSRS

Table 19 on *Page 65* contain the internal ellipsoid parameters and transformation parameters used in the receiver. The values contained in these tables were derived from the following DMA technical reports:

1. TR 8350.2 Department of Defence World Geodetic System 1984 and Relationships with Local Geodetic Systems - Revised March 1, 1988.
2. TR 8350.2B Supplement to Department of Defence World Geodetic System 1984 Technical Report - Part II - Parameters, Formulas, and Graphics for the Practical Application of WGS84 - December 1, 1987.
3. TR 8350.2 Department of Defense World Geodetic System 1984 National Imagery and Mapping Agency Technical Report, Third Addition, Amendment 1 - January 3, 2000

Table 19: Reference Ellipsoid Constants

ELLIPSOID	ID CODE	a (meters)	1/f	f
Airy 1830	AW	6377563.396	299.3249646	0.00334085064038
Modified Airy	AM	6377340.189	299.3249646	0.00334085064038
Australian National	AN	6378160.0	298.25	0.00335289186924
Bessel 1841	BR	6377397.155	299.1528128	0.00334277318217
Clarke 1866	CC	6378206.4	294.9786982	0.00339007530409
Clarke 1880	CD	6378249.145	293.465	0.00340756137870
Everest (India 1830)	EA	6377276.345	300.8017	0.00332444929666
Everest (Brunei & E.Malaysia)	EB	6377298.556	300.8017	0.00332444929666
Everest (W.Malaysia & Singapore)	EE	6377304.063	300.8017	0.00332444929666
Geodetic Reference System 1980	RF	6378137.0	298.257222101	0.00335281068118
Helmert 1906	HE	6378200.0	298.30	0.00335232986926
Hough 1960	HO	6378270.0	297.00	0.00336700336700
International 1924	IN	6378388.0	297.00	0.00336700336700
South American 1969	SA	6378160.0	298.25	0.00335289186924
World Geodetic System 1972	WD	6378135.0	298.26	0.00335277945417
World Geodetic System 1984	WE	6378137.0	298.257223563	0.00335281066475

Table 20: Datum Transformation Parameters

Datum ID# ^a	NAME	DX	DY	DZ	DATUM DESCRIPTION	ELLIPSOID
1	ADIND	-162	-12	206	This datum has been updated, see ID# 65 ^b	Clarke 1880
2	ARC50	-143	-90	-294	ARC 1950 (SW & SE Africa)	Clarke 1880
3	ARC60	-160	-8	-300	This datum has been updated, see ID# 66 ^b	Clarke 1880
4	AGD66	-133	-48	148	Australian Geodetic Datum 1966	Australian National
5	AGD84	-134	-48	149	Australian Geodetic Datum 1984	Australian National
6	BUKIT	-384	664	-48	Bukit Rimpah (Indonesia)	Bessel 1841
7	ASTRO	-104	-129	239	Camp Area Astro (Antarctica)	International 1924
8	CHATM	175	-38	113	Chatham 1971 (New Zealand)	International 1924
9	CARTH	-263	6	431	Carthage (Tunisia)	Clarke 1880
10	CAPE	-136	-108	-292	CAPE (South Africa)	Clarke 1880
11	DJAKA	-377	681	-50	Djakarta (Indonesia)	Bessel 1841
12	EGYPT	-130	110	-13	Old Egyptian	Helmert 1906
13	ED50	-87	-98	-121	European 1950	International 1924
14	ED79	-86	-98	-119	European 1979	International 1924
15	GUNSG	-403	684	41	G. Segara (Kalimantan - Indonesia)	Bessel 1841
16	GEO49	84	-22	209	Geodetic Datum 1949 (New Zealand)	International 1924
17	GRB36	375	-111	431	Do not use. Use ID# 76 instead. ^c	Airy 1830
18	GUAM	-100	-248	259	Guam 1963 (Guam Island)	Clarke 1866
19	HAWAII	89	-279	-183	Do not use. Use ID# 77 or ID# 81 instead. ^c	Clarke 1866
20	KAUAI	45	-290	-172	Do not use. Use ID# 78 or ID# 82 instead. ^c	Clarke 1866
21	MAUI	65	-290	-190	Do not use. Use ID# 79 or ID# 83 instead. ^c	Clarke 1866
22	OAHU	56	-284	-181	Do not use. Use ID# 80 or ID# 84 instead. ^c	Clarke 1866
23	HERAT	-333	-222	114	Herat North (Afghanistan)	International 1924
24	HJORS	-73	46	-86	Hjorsey 1955 (Iceland)	International 1924

Continued on Page 66

25	HONGK	-156	-271	-189	Hong Kong 1963	International 1924
26	HUTZU	-634	-549	-201	This datum has been updated, see ID# 68 ^b	International 1924
27	INDIA	289	734	257	Do not use. Use ID# 69 or ID# 70 instead. ^c	Everest (EA)
28	IRE65	506	-122	611	Do not use. Use ID# 71 instead. ^c	Modified Airy
29	KERTA	-11	851	5	Kertau 1948 (West Malaysia and Singapore)	Everest (EE)
30	KANDA	-97	787	86	Kandawala (Sri Lanka)	Everest (EA)
31	LIBER	-90	40	88	Liberia 1964	Clarke 1880
32	LUZON	-133	-77	-51	Do not use. Use ID# 72 instead. ^c	Clarke 1866
33	MINDA	-133	-70	-72	This datum has been updated, see ID# 73 ^b	Clarke 1866
34	MERCH	31	146	47	Merchich (Morocco)	Clarke 1880
35	NAHR	-231	-196	482	This datum has been updated, see ID# 74 ^b	Clarke 1880
36	NAD83	0	0	0	N. American 1983 (Includes Areas 37-42)	GRS-80
37	CANADA	-10	158	187	N. American Canada 1927	Clarke 1866
38	ALASKA	-5	135	172	N. American Alaska 1927	Clarke 1866
39	NAD27	-8	160	176	N. American Conus 1927	Clarke 1866
40	CARIBB	-7	152	178	This datum has been updated, see ID# 75 ^b	Clarke 1866
41	MEXICO	-12	130	190	N. American Mexico	Clarke 1866
42	CAMER	0	125	194	N. American Central America	Clarke 1866
43	MINNA	-92	-93	122	Nigeria (Minna)	Clarke 1880
44	OMAN	-346	-1	224	Oman	Clarke 1880
45	PUERTO	11	72	-101	Puerto Rica and Virgin Islands	Clarke 1866
46	QORNO	164	138	-189	Qornoq (South Greenland)	International 1924
47	ROME	-255	-65	9	Rome 1940 Sardinia Island	International 1924
48	CHUA	-134	229	-29	South American Chua Astro (Paraguay)	International 1924
49	SAM56	-288	175	-376	South American (Provisional 1956)	International 1924
50	SAM69	-57	1	-41	South American 1969	S. American 1969
51	CAMPO	-148	136	90	S. American Campo Inchauspe (Argentina)	International 1924
52	SACOR	-206	172	-6	South American Corrego Alegre (Brazil)	International 1924
53	YACAR	-155	171	37	South American Yacare (Uruguay)	International 1924
54	TANAN	-189	-242	-91	Tananarive Observatory 1925 (Madagascar)	International 1924
55	TIMBA	-689	691	-46	This datum has been updated, see ID# 85 ^b	Everest (EB)
56	TOKYO	-128	481	664	This datum has been updated, see ID# 86 ^b	Bessel 1841
57	TRIST	-632	438	-609	Tristan Astro 1968 (Tristan du Cunha)	International 1924
58	VITI	51	391	-36	Viti Levu 1916 (Fiji Islands)	Clarke 1880
59	WAK60	101	52	-39	This datum has been updated, see ID# 67 ^b	Hough 1960
60	WGS72	0	0	4.5	World Geodetic System - 72	WGS72
61	WGS84	0	0	0	World Geodetic System - 84	WGS84
62	ZANDE	-265	120	-358	Zanderidj (Surinam)	International 1924
63	USER	0	0	0	User Defined Datum Defaults	User ^a
64	CSRS	-0.9833	1.9082	0.4878	Canadian Spatial Ref. System (epoch 2005.0)	GRS-80
65	ADIM	-166	-15	204	Adindan (Ethiopia, Mali, Senegal & Sudan) ^b	Clarke 1880
66	ARSM	-160	-6	-302	ARC 1960 (Kenya, Tanzania) ^b	Clarke 1880
67	ENW	102	52	-38	Wake-Eniwetok (Marshall Islands) ^b	Hough 1960
68	HTN	-637	-549	-203	Hu-Tzu-Shan (Taiwan) ^b	International 1924

Continued on Page 67

69	INDB	282	726	254	Indian (Bangladesh) ^c	Everest (EA)
70	INDI	295	736	257	Indian (India, Nepal) ^c	Everest (EA)
71	IRL	506	-122	611	Ireland 1965 ^c	Modified Airy
72	LUZA	-133	-77	-51	Luzon (Philippines excluding Mindanao Is.) ^{cd}	Clarke 1866
73	LUZB	-133	-79	-72	Mindanao Island ^b	Clarke 1866
74	NAHC	-243	-192	477	Nahrwan (Saudi Arabia) ^b	Clarke 1880
75	NASP	-3	142	183	N. American Caribbean ^b	Clarke 1866
76	OGBM	375	-111	431	Great Britain 1936 (Ordinance Survey) ^c	Airy 1830
77	OHAA	89	-279	-183	Hawaiian Hawaii ^c	Clarke 1866
78	OHAB	45	-290	-172	Hawaiian Kauai ^c	Clarke 1866
79	OHAC	65	-290	-190	Hawaiian Maui ^c	Clarke 1866
80	OHAD	58	-283	-182	Hawaiian Oahu ^c	Clarke 1866
81	OHIA	229	-222	-348	Hawaiian Hawaii ^c	International 1924
82	OHIB	185	-233	-337	Hawaiian Kauai ^c	International 1924
83	OHIC	205	-233	-355	Hawaiian Maui ^c	International 1924
84	OHID	198	-226	-347	Hawaiian Oahu ^c	International 1924
85	TIL	-679	669	-48	Timbalai (Brunei and East Malaysia) 1948 ^b	Everest (EB)
86	TOYM	-148	507	685	Tokyo (Japan, Korea and Okinawa) ^b	Bessel 1841

- a. The default user datum is WGS84. See also the USERDATUM and USEREXPDATUM commands starting on *Page 133*. The following logs report the datum used according to the GPSCard Datum ID column: BESTPOS, BESTUTM, MATCHEDPOS and PSRPOS.
- b. The updated datum have the new x, y and z translation values updated to the latest numbers. The old datum values can still be used for backwards compatibility.
- c. Use the corrected datum only (with the higher ID#) as the old datum is incorrect.
- d. The original LUZON values are the same as for LUZA but the original has an error in the code.

2.6.14 DGPSEPHMDELAY DGPS ephemeris delay DGPS

The DGPSEPHMDELAY command is used to set the ephemeris delay when operating as a base station. The ephemeris delay sets a time value by which the base station will continue to use the old ephemeris data. A delay of 120 to 300 seconds will typically ensure that the rover stations have collected updated ephemeris. After the delay period is passed, the base station will begin using new ephemeris data.

The factory default of 120 seconds matches the RTCM standard.

Abbreviated ASCII Syntax:

Message ID: 142

DGPSEPHMDELAY delay

Field	Field Type	ASCII Value	Binary Value	Description	Binary Format	Binary Bytes	Binary Offset
1	header	-	-	This field contains the command name or the message header depending on whether the command is abbreviated ASCII, ASCII or binary, respectively.	-	H	0
2	delay	0 to 600 s		Minimum time delay before new ephemeris is used.	ULong	4	H

ASCII Example (reference):

```
DGPSEPHMDELAY 120
```

-
- The RTCA Standard stipulates that a base station shall wait five minutes after receiving a new ephemeris before transmitting differential corrections to rover stations that are using the RTCA standard. This time interval ensures that the rover stations will have received the new ephemeris, and will compute differential positioning based upon the same ephemeris. Therefore, for RTCA base stations, the recommended ephemeris delay is 300 seconds.
-

2.6.15 DGPSRXID

This command is now obsolete and has been replaced by the PSRDIFFSOURCE and RTKSOURCE commands. Please see *Pages 104* and *113* respectively for more information on these commands.

2.6.16 DGPSTIMEOUT Set maximum age of differential data DGPS

This command is used to set the maximum age of pseudorange differential data that will be used when operating as a rover station. Pseudorange differential data received that is older than the specified time will be ignored. RTK differential data is fixed at 60 seconds and cannot be changed. See DGPSEPHEMDELAY on *Page 68* to set the ephemeris changeover delay for base stations.

Abbreviated ASCII Syntax:

Message ID: 127

DGPSTIMEOUT delay

Field	Field Type	ASCII Value	Binary Value	Description	Binary Format	Binary Bytes	Binary Offset
1	header	-	-	This field contains the command name or the message header depending on whether the command is abbreviated ASCII, ASCII or binary, respectively.	-	H	0
2	delay	2 to 1000 s		Maximum pseudorange differential age.	ULong	4	H

ASCII Example (rover):

```
DGPSTIMEOUT 60
```

-
- The RTCA Standard for SCAT-I stipulates that the maximum age of differential correction messages cannot be greater than 22 seconds. Therefore, for RTCA rover users, the recommended DGPS delay setting is 22.
-

2.6.17 DGPSTXID DGPS transmit ID DGPS

This command sets the station ID value for the receiver when it is transmitting corrections. This allows for the easy identification of which base station was the source of the data.

Abbreviated ASCII Syntax:

Message ID: 144

DGPSTXID type ID

Field	Field Type	ASCII Value	Binary Value	Description	Binary Format	Binary Bytes	Binary Offset
1	header	-	-	This field contains the command name or the message header depending on whether the command is abbreviated ASCII, ASCII or binary, respectively.	-	H	0
2	type	See Table 31, DGPS Type on Page 105		ID Type	Enum	4	H
3	ID	String [max. 5] or "ANY"		ID string ANY type defaults: RTCM - 0 RTCMV3 - 0 RTCA - AAAA CMR - 0 The following range values are in affect: 0 ≤ CMR ID ≤ 31 0 ≤ RTCM ID ≤ 1023 0 ≤ RTCMV3 ID ≤ 4095 RTCA: any four character string containing only alpha (a-z) or numerical characters (0-9)	String [max. 5]	Variable ^a	Variable

a. In the binary log case additional bytes of padding are added to maintain 4 byte alignment

ASCII Examples:

- DGPSTXID RTCM 2 - using an RTCM type and ID
- DGPSTXID CMR 30 - using a CMR type and ID
- DGPSTXID CMR "ANY" - using the default CMR ID
- DGPSTXID RTCA D36 - using an RTCA type and ID
- DGPSTXID RTCMV3 2050 - using an RTCMV3 type and ID

2.6.18 DYNAMICS Tune receiver parameters

This command adjusts the receiver dynamics to that of your environment. It is used to optimally tune receiver parameters.

The DYNAMICS command adjusts the Tracking State transition time-out value of the receiver, see *Table 64, Tracking State on Page 239*. When the receiver loses the position solution, see *Table 48, Solution Status on Page 163*, it attempts to steer the tracking loops for fast reacquisition (5 s time-out by default). The DYNAMICS command allows you to adjust this time-out value, effectively increasing the steering time. The three states 0, 1, and 2 set the time-out to 5, 10, or 20 seconds respectively.

-
- ☒ 1. The DYNAMICS command should only be used by advanced users of GPS. The default of AIR should **not** be changed except under very specific conditions.
 - 2. The DYNAMICS command affects satellite reacquisition. The constraint of the DYNAMICS filter with FOOT is very tight and is appropriate for a user on foot. A sudden tilted or up and down movement, for example while a tractor is moving slowly along a track, may trip the RTK filter to reset and cause the position to jump. AIR should be used in this case.
-

Abbreviated ASCII Syntax:

Message ID: 258

DYNAMICS dynamics

Field	Field Type	ASCII Value	Binary Value	Description	Binary Format	Binary Bytes	Binary Offset
1	header	-	-	This field contains the command name or the message header depending on whether the command is abbreviated ASCII, ASCII or binary, respectively.	-	H	0
2	dynamics	See <i>Table 21</i>		Receiver dynamics based on the user's.	Enum	4	H

Table 21: User Dynamics

Binary	ASCII	Description
0	AIR	Receiver is in an aircraft or a land vehicle, for example a high speed train, with velocity greater than 110 km/h (30 m/s). This is also the most suitable dynamic for a jittery vehicle at any speed. See also <i>Note #2</i> above.
1	LAND	Receiver is in a stable land vehicle with velocity less than 110 km/h (30 m/s)
2	FOOT	Receiver is being carried by a person with velocity less than 11 km/h (3 m/s)

Example:

DYNAMICS FOOT

2.6.19 ECUTOFF Set satellite elevation cut-off

This command sets the elevation cut-off angle for tracked satellites. The receiver will not start automatically searching for a satellite until it rises above the cut-off angle. Tracked satellites that fall below the cut-off angle will no longer be tracked unless they were manually assigned (see the ASSIGN command).

In either case, satellites below the ECUTOFF angle will be eliminated from the internal position and clock offset solution computations.

This command permits a negative cut-off angle; it could be used in these situations:

- The antenna is at a high altitude, and thus can look below the local horizon
- Satellites are visible below the horizon due to atmospheric refraction

Abbreviated ASCII Syntax:

Message ID: 50

ECUTOFF angle

Field	Field Type	ASCII Value	Binary Value	Description	Binary Format	Binary Bytes	Binary Offset
1	header	-	-	This field contains the command name or the message header depending on whether the command is abbreviated ASCII, ASCII or binary, respectively.	-	H	0
2	angle	±90.0 degrees		Elevation cut-off angle relative to horizon.	Float	4	H

ASCII Example:

```
ECUTOFF 10.0
```

-
- ☒ 1. Care must be taken when using ECUTOFF because the signals from lower elevation satellites are travelling through more atmosphere and are therefore degraded. Use of satellites below 5 degrees is not recommended.
 - 2. This command does not affect the RTK mode elevation cut-off angle. It only affects which satellites are tracked. See the RTKELEV MASK command on *Page III*.
 - 3. This command does not affect the tracking of SBAS satellites.
-

2.6.20 EXTERNALCLOCK Set external clock parameters

Overview

The EXTERNALCLOCK command allows the OEM4-G2L, or OEM4-G2 to operate with an optional external oscillator. You are able to optimally adjust the clock model parameters of these receivers for various types of external clocks.

-
- ☒ 1. This command will affect the interpretation of the CLOCKMODEL log.
 - 2. If the EXTERNALCLOCK command is enabled and set for an external clock (TCXO, OCXO, RUBIDIUM, CESIUM, or USER) and the CLOCKADJUST command, see *Page 55*, is ENABLED, then the clock steering process takes over the VARF output pins and may conflict with a previously entered FREQUENCYOUT command, see *Page 81*. If clocksteering is not used with the external oscillator, the clocksteering process must be disabled by using the CLOCKADJUST DISABLE command.
-

There are three steps involved in using an external oscillator:

1. Follow the procedure outlined in *Volume 1* of this manual set to connect an external oscillator to your OEM4-G2L, or OEM4-G2.
2. Using the EXTERNALCLOCK command, select a standard oscillator and its operating frequency.
3. Using the CLOCKADJUST command, disable the clocksteering process if external clocksteering is not used.

Theory

An unsteered oscillator can be approximated by a three-state clock model, with two states representing the range bias and range bias rate, and a third state assumed to be a Gauss-Markov (GM) process representing the range bias error generated from satellite clock dither. The third state is included because the Kalman filter assumes an (unmodeled) white input error. The significant correlated errors produced by satellite clock dither are obviously not white and the Markov process is an attempt to handle this kind of short-term variation.

The internal units of the new clock model's three states (offset, drift and GM state) are meters, meters per second, and meters. When scaled to time units for the output log, these become seconds, seconds per second, and seconds, respectively. Note that the old units of the third clock state (drift rate) were meters per second per second.

The user has control over 3 process noise elements of the linear portion of the clock model. These are the h_0 , h_{-1} , and h_{-2} elements of the power law spectral density model used to describe the frequency noise characteristics of oscillators:

$$S_y(f) = \frac{h_{-2}}{f^2} + \frac{h_{-1}}{f} + h_0 + h_1 f + h_2 f^2$$

where f is the sampling frequency and $S_y(f)$ is the clock’s power spectrum. Typically only h_0 , h_{-1} , and h_{-2} affect the clock’s Allan variance and the clock model’s process noise elements.

Usage

Before using an optional external oscillator, several clock model parameters must be set. There are default settings for a voltage-controlled temperature-compensated crystal oscillator (VCTCXO), ovenized crystal oscillator (OCXO), Rubidium and Cesium standard, which are given in *Table 23* on *Page 76*. Or, the user may choose to supply customized settings.

Abbreviated ASCII Syntax:

Message ID: 230

EXTERNALCLOCK clocktype [freq] [h0[h₋₁[h₋₂]]]

Field	Field Type	ASCII Value	Binary Value	Description	Binary Format	Binary Bytes	Binary Offset
1	header	-	-	This field contains the command name or the message header depending on whether the command is abbreviated ASCII, ASCII or binary, respectively.	-	H	0
2	clocktype	See <i>Table 22 on Page 76</i>		Clock type	Enum	4	H
3	freq	5MHz	0	Optional frequency. If a value is not specified, the default is 5 MHz.	Enum	4	H+4
		10MHz	1				
4	h0	1.0 e-31 to 1.0 e-18		Optional timing standards. These fields are only valid when the USER clocktype is selected.	Double	8	H+8
5	h ₋₁	1.0 e-31 to 1.0 e-18			Double	8	H+16
6	h ₋₂	1.0 e-31 to 1.0 e-18			Double	8	H+24

ASCII Example:

EXTERNALCLOCK DISABLE

or

EXTERNALCLOCK USER 10MHZ 1.0167e-23 6.87621e-25 8.1762e-26

or

EXTERNALCLOCK TCXO 5MHZ

Table 22: Clock Type

ASCII	Binary	Description
DISABLE	0	Turns the external clock input off, reverts back to the on-board VCTCXO
TCXO	1	Sets the pre-defined values for a VCTCXO
OCXO	2	Sets the pre-defined values for an OCXO
RUBIDIUM	3	Sets the pre-defined values for a rubidium oscillator
CESIUM	4	Sets the pre-defined values for a cesium oscillator
USER	5	Defines custom process noise elements

Table 23: Pre-Defined Values for Oscillators

Clock Type	h_0	h_{-1}	h_{-2}
VCTCXO	1.0 e-21	1.0 e-20	1.0 e-20
OCXO	2.51 e-26	2.51 e-23	2.51 e-22
Rubidium	1.0 e-23	1.0 e-22	1.3 e-26
Cesium	2.0 e-20	7.0 e-23	4.0 e-29

2.6.21 FIX Constrain to fixed height or position

This command fixes various parameters of the receiver such as height or position. For various applications, fixing these values can assist in improving acquisition times and accuracy of position or corrections. For example, fixing the position and height is a requirement for differential base stations as it provides a truth position to base the differential corrections from.

If you enter a FIXPOSDATUM command, see *Page 80*, the FIX command is then issued internally with the FIXPOSDATUM command values translated to WGS84. It is the FIX command that appears in the RXCONFIG log. If the FIX or the FIXPOSDATUM command are used, their newest values overwrite the internal FIX values.

-
- ☒ 1. NovAtel strongly recommends that the FIX POSITION entered be good to within a few meters. This level of accuracy can be obtained from a receiver using single point positioning once 5 or 6 satellites are being tracked.
 - 2. Any setting other than FIX POSITION will disable output of differential corrections unless the MOVINGBASESTATION command is set to ENABLE, see also *Page 98*.
-

Error checking is done on the entered fixed position. If less than 3 measurements are available, the solution status indicates PENDING. While the status is PENDING, the fixed position value is not used internally (for example, for updating the clock model, or controlling the satellite signal search). Once 3 or more measurements are available, the error checking is performed. If the error check passes, the solution status changes to SOL_COMPUTED, and the fixed position is used internally. At the first level of error, when the fixed position is off by approximately 25-50 meters, the output position log indicates INTEGRITY_WARNING in the solution status field, but the fixed position value is still used by the internal computations. If the error reaches the second level, a few kilometers, the receiver does not use the fixed position at all and indicates INVALID_FIX in the solution status. Note that a fixed position obtained from the POSAVE function is treated the same way in the error checking as one entered manually.

Abbreviated ASCII Syntax:

Message ID: 44

FIX type [param1 [param2 [param3]]]

Field	Field Type	ASCII Value	Binary Value	Description	Binary Format	Binary Bytes	Binary Offset
1	header	-	-	This field contains the command name or the message header depending on whether the command is abbreviated ASCII, ASCII or binary, respectively.	-	H	0
2	type	See Table 25 on Page 78		Fix type	Enum	4	H
3	param1	See Table 24		Parameter 1	Double	8	H + 4
4	param2			Parameter 2	Double	8	H + 12
5	param3			Parameter 3	Double	8	H + 20

ASCII Example:

```
FIX HEIGHT 4.567
```

Table 24: FIX Parameters

ASCII Type Name	Parameter 1	Parameter 2	Parameter 3
AUTO	Not used	Not used	Not used
HEIGHT	Ellipsoidal (MSL) height ^a (-1000 to 20000000 m)	Not used	Not used
NONE	Not used	Not used	Not used
POSITION	Lat (-90 to 90 deg)	Lon (-360 to 360 deg)	Mean sea level (MSL) height ^a (-1000 to 20000000 m)

- a. For a discussion on height, refer to the *GPS Overview* chapter of the *GPS+ Reference Manual* available on our website at <http://www.novatel.com/support/docupdates.htm>.

Table 25: Fix Types

ASCII Name	Binary Value	Description
NONE	0	Unfix. Clears any previous FIX commands.
AUTO	1	Configures the receiver to fix the height at the last calculated value if the number of satellites available is insufficient for a 3-D solution. This provides a 2-D solution. Height calculation will resume when the number of satellites available allows a 3-D solution.
HEIGHT	2	Configures the receiver in 2-D mode with its height constrained to a given value. The command would be used mainly in marine applications where height in relation to mean sea level may be considered to be approximately constant. The height entered using this command is always referenced to the geoid (mean sea level, see the BESTPOS log on <i>Page 161</i>) and uses units of meters. The receiver is capable of receiving and applying differential corrections from a base station while FIX HEIGHT is in effect. The FIX HEIGHT command will override any previous FIX HEIGHT or FIX POSITION command Note: This command only affects pseudorange corrections and solutions, and so has no meaning within the context of RT-2 and RT-20.

Continued on Page 79

ASCII Name	Binary Value	Description
POSITION	3	<p>Configures the receiver with its position fixed. This command is used when it is necessary to generate differential corrections.</p> <p>For both pseudorange and differential corrections, this command must be properly initialized before the receiver can operate as a GPS base station. Once initialized, the receiver will compute differential corrections for each satellite being tracked. The computed differential corrections can then be output to rover stations by utilizing any of the following receiver differential corrections data log formats: RTCM, RTCMV3, RTCA, or CMR. See the <i>OEM4 Family User Manual Volume 1</i> for information on using the receiver for differential applications.</p> <p>The values entered into the FIX POSITION command should reflect the precise position of the base station antenna phase centre. Any errors in the FIX POSITION coordinates will directly bias the corrections calculated by the base receiver.</p> <p>The receiver performs all internal computations based on WGS84 and the datum command is defaulted as such. The datum in which you choose to operate (by changing the DATUM command) will be internally converted to and from WGS84. Therefore, all differential corrections are based on WGS84, regardless of your operating datum. The FIX POSITION command will override any previous FIX HEIGHT or FIX POSITION command settings.</p>
PENDING	18	There is not enough measurements available to verify the FIX POSITION entry.
INVALID_FIX	19	The errors in the FIX POSITION entry are too large.

2.6.22 FIXPOSDATUM Set position through a specified datum

This command sets the position by referencing the position parameters through a specified datum. The position is transformed into the same datum as that in the receiver's current setting. The FIX command, see *Page 77*, is then issued internally with the FIXPOSDATUM command values. It is the FIX command that appears in the RXCONFIG log. If the FIX or the FIXPOSDATUM command are used, their newest values overwrite the internal FIX values.

Abbreviated ASCII Syntax:

Message ID: 761

FIXPOSDATUM datum [lat [lon [height]]]

Field	Field Type	ASCII Value	Binary Value	Description	Binary Format	Binary Bytes	Binary Offset
1	header	-	-	This field contains the command name or the message header depending on whether the command is abbreviated ASCII, ASCII or binary, respectively.	-	H	0
2	datum	See <i>Table 20 on Page 65</i>		Datum ID	Enum	4	H
3	lat	-90 to +90		Latitude (degrees)	Double	8	H + 4
4	lon	-360 to +360		Longitude (degrees)	Double	8	H + 12
5	height	-1000 to 20000000		Mean sea level (MSL) height (m) ^a	Double	8	H + 20

- a. For a discussion on height, refer to the *GPS Overview* chapter of the *GPS+ Reference Manual* available on our website at <http://www.novatel.com/support/docupdates.htm>.

ASCII Example:

```
FIXPOSDATUM USER 51.11633810554 -114.03839550586 1048.2343
```

2.6.23 FREQUENCYOUT Set output pulse train available on VARF

This command sets the output pulse train available on the variable frequency (VARF) pin.

The output waveform will be coherent with the 1PPS output, see the note and *Figure 2 on Page 82*.

- ☒ If the CLOCKADJUST command is ENABLED, see *Page 55*, and the receiver is configured to use an external reference frequency (set in the EXTERNALCLOCK command, see *Page 74*, for an external clock - TCXO, OCXO, RUBIDIUM, CESIUM, or USER), then the clock steering process will take over the VARF output pins and may conflict with a previously entered FREQUENCYOUT command.

Abbreviated ASCII Syntax:

Message ID: 232

FREQUENCYOUT [switch] [pulsewidth] [period]

Field	Field Type	ASCII Value	Binary Value	Description	Binary Format	Binary Bytes	Binary Offset
1	header	-	-	This field contains the command name or the message header depending on whether the command is abbreviated ASCII, ASCII or binary, respectively.	-	H	0
2	switch	DISABLE	0	Disable will cause the output to be fixed low (default)	Enum	4	H
		ENABLE	1	Enables customized frequency output			
3	pulse width	(0 to 262144)		Number of 25 ns steps for which the output will be high. Duty cycle = pulsewidth / period. Must be less than or equal to the period. (default = 0). If pulsewidth is the same as the period, the output will be a high DC signal. If pulsewidth is 1/2 the period, then the output will be a square wave.	Ulong	4	H+4
4	period	(0 to 262144)		Signal period in 25 ns steps. Frequency Output = 40,000,000 / Period. (default = 0).	Ulong	4	H+8

ASCII Example:

```
FREQUENCYOUT ENABLE 2 4
```

This example will generate a 50% duty cycle 10 MHz square wave.

- ☒ *Figure 2*, below, shows how the chosen pulse width will be frequency locked but not necessarily phase locked.

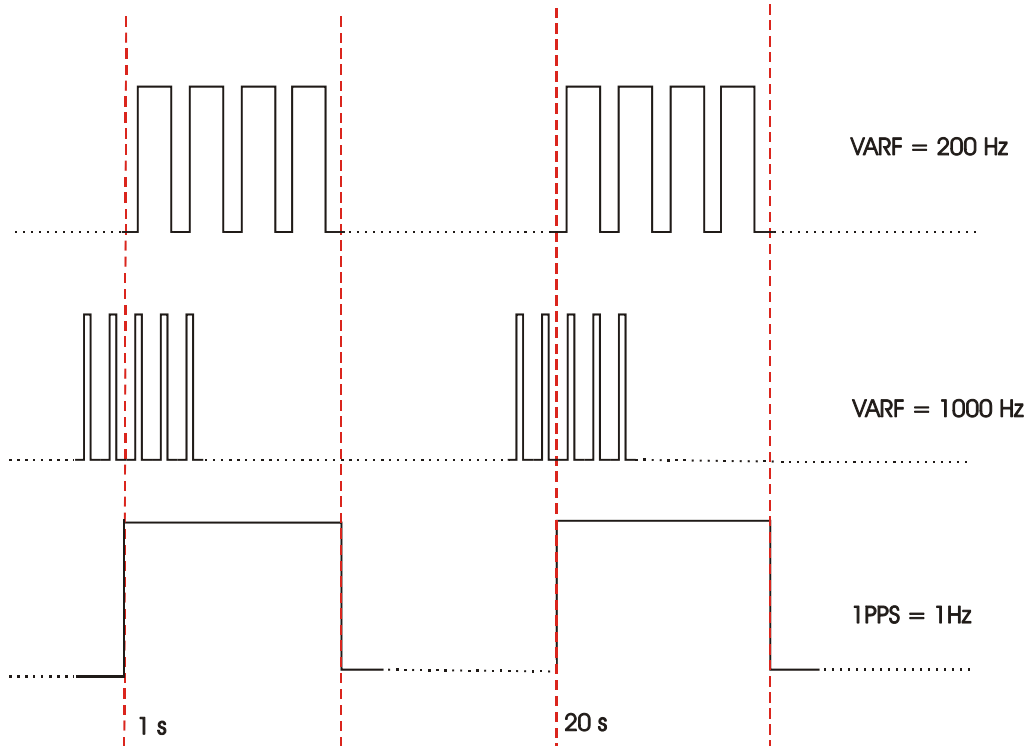

Figure 2: Pulse Width and 1PPS Coherency

2.6.24 FRESET Clear selected data from NVM and reset

This command clears data which is stored in non-volatile memory. Such data includes the almanac, ephemeris, and any user-specific configurations. The commands, ephemeris, almanac, and L-Band related data, excluding the subscription information, can be cleared by using the STANDARD target. The model can only be cleared by using the MODEL target. The receiver is forced to hardware reset.

Abbreviated ASCII Syntax:

Message ID: 20

FRESET [target]

Field	Field Type	ASCII Value	Binary Value	Description	Binary Format	Binary Bytes	Binary Offset
1	header	-	-	This field contains the command name or the message header depending on whether the command is abbreviated ASCII, ASCII or binary, respectively.	-	H	0
2	target	See Table 26		What data is to be reset by the receiver.	Enum	4	H

Input Example:

FRESET COMMAND

- ☒ FRESET STANDARD (which is also the default) causes any commands, ephemeris, GPS almanac and SBAS almanac data (COMMAND, GPSALMANAC, GPSEPHEM and SBASALMANAC in Table 26) previously saved to NVM to be erased.

Table 26: FRESET Target

Binary	ASCII	Description
0	STANDARD	Resets commands, ephemeris, and almanac (default). Also resets all L-Band related data except for the subscription information.
1	COMMAND	Resets the stored commands (saved configuration)
2	GPSALMANAC	Resets the stored almanac
3	GPSEPHEM	Resets stored ephemeris
5	MODEL	Resets the currently selected model
11	CLKCALIBRATION	Resets the parameters entered using the CLOCKCALIBRATE command
20	SBASALMANAC	Resets the stored SBAS almanac
21	LAST_POSITION	Resets the position using the last stored position

2.6.25 GGAQUALITY *Customize the GPGGA GPS quality indicator*

This command allows you to customize the NMEA GPGGA GPS quality indicator. See also the GPGGA log on *Page 188*.

Abbreviated ASCII Syntax:

Message ID: 20

GGAQUALITY #entries [pos type1][qual1] [pos type2] [qual2]...

Field	Field Type	ASCII Value	Binary Value	Description	Binary Format	Binary Bytes	Binary Offset
1	header	-	-	This field contains the command name or the message header depending on whether the command is abbreviated ASCII, ASCII or binary, respectively.	-	H	0
2	#entries	0-20		The number of position types that are being re-mapped (20 max.)	Ulong	4	H+4
3	pos type1	See <i>Table 47, Position or Velocity Type on Page 162</i>		The 1st position type that is being re-mapped	Enum	4	H+8
4	qual1	See <i>Page 188</i>		The number that will appear in the GPGGA log for the 1st position type	Ulong	4	H+12
5	pos type2	See <i>Table 47 on Page 162</i>		The 2nd position type that is being re-mapped, if applicable	Enum	4	H+16
6	qual2	See <i>Page 188</i>		The number that will appear in the GPGGA log for the 2nd solution type, if applicable	Ulong	4	H+20
...	Next solution type and quality indicator set, if applicable				Variable		

Input Example 1:

```
GGAQUALITY 1 WAAS 2
```

Makes the WAAS solution type show 2 as the quality indicator.

Input Example 2:

```
GGAQUALITY 2 WAAS 2 NARROW_FLOAT 3
```

Makes the WAAS solution type show 2, and the NARROW_FLOAT solution type show 3, as their quality indicators.

Input Example 3:

```
GGAQUALITY 0
```

Sets all the quality indicators back to the default.

2.6.26 HPSEED Specify the OmniSTAR HP seed position

This OmniSTAR HP command allows you to specify the seed position for OmniSTAR HP.

Abbreviated ASCII Syntax:

Message ID: 782

HPSEED mode [lat lon hgt latσ lonσ hgtσ [datum undulation]]

Field	Field Type	ASCII Value	Binary Value	Description	Binary Format	Binary Bytes	Binary Offset
1	header	-	-	This field contains the command name or the message header depending on whether the command is abbreviated ASCII, ASCII or binary, respectively.	-	H	0
2	mode	See Table 27 below		Seeding mode	Enum	4	H
3	lat	-90 to +90		Latitude (degrees)	Double	8	H+4
4	lon	-360 to +360		Longitude (degrees)	Double	8	H+12
5	hgt	-1000 to 20000000		Height above mean sea level (m)	Double	8	H+20
6	latσ			Latitude standard deviation (m)	Float	4	H+28
7	lonσ			Longitude standard deviation (m)	Float	4	H+32
8	hgtσ			Height standard deviation (m)	Float	4	H+36
9	datum	See Table 20, Datum Transformation Parameters on Page 65		Datum ID (default = WGS84)	Enum	4	H+40
10	undulation	see the UNDULATION command's option field values on Page 128		Undulation type (default = TABLE)	Enum	4	H+44

Table 27: Seeding Mode

Binary Value	ASCII Mode Name	Description
0	RESET	Clear current seed and restart HP ^a
1	SET	Specify a position and inject it into HP as seed
2	STORE	Store current HP position in NVM for use as a future seed ^a
3	RESTORE	Inject NVM-stored position into HP as seed ^a

a. No further parameters are needed in the syntax

ASCII Examples:

- To store the current HP position so that it can be used as the seed in the future: HPSEED STORE
- To use the stored HP position as the seed: HPSEED RESTORE
- To use a known position in the native datum of OmniSTAR HP as the seed:

```
HPSEED SET 51.11633810554 -114.03839550586 1048.2343
0.0086,0.0090,0.0191
```
- To use a known position from a datum other than the native OmniSTAR HP datum as the seed:

```
HPSEED SET 51.11633810554 -114.03839550586 1048.2343
0.0086,0.0090,0.0191 CANADA EGM96
```

2.6.27 HPSTATICINIT Set OmniSTAR HP static initialization

This command enables or disables static initialization of OmniSTAR HP. If the OmniSTAR HP process knows that the receiver is stationary, it can converge more quickly.

Abbreviated ASCII Syntax:

Message ID: 780

HPSTATICINIT switch

Field	Field Type	ASCII Value	Binary Value	Description	Binary Format	Binary Bytes	Binary Offset
1	header	-	-	This field contains the command name or the message header depending on whether the command is abbreviated ASCII, ASCII or binary, respectively.	-	H	0
2	switch	DISABLE	0	The receiver is not stationary	Enum	4	H
		ENABLE	1	The receiver is stationary			

ASCII Example:

```
HPSTATICINIT ENABLE
```

-
- If the HP filter perceives receiver motion, it may abort static initialization. See the Static Initialization Mode bit in the HP Status field of the LBANDSTAT log, details starting on *Page 209*, to confirm that static initialization is in progress.
-

2.6.28 INTERFACEMODE Set receive or transmit modes for ports DGPS

This command allows the user to specify what type of data a particular port on the receiver can transmit and receive. The receive type tells the receiver what type of data to accept on the specified port. The transmit type tells the receiver what kind of data it can generate. For example, you would set the receive type on a port to RTCA in order to accept RTCA differential corrections.

It is also possible to disable or enable the generation or transmission of command responses for a particular port. Disabling of responses is important for applications where data is required in a specific form and the introduction of extra bytes may cause problems, for example RTCA, RTCM, RTCMV3 or CMR. Disabling a port prompt is also useful when the port is connected to a modem or other device that will respond with data the receiver does not recognize.

When INTERFACEMODE *port* NONE NONE OFF is set, the specified port is disabled from interpreting any input or output data. Therefore, no commands or differential corrections are decoded by the specified port. Data can be passed through the disabled port and be output from an alternative port using the pass-through logs PASSCOM, PASSXCOM, PASSAUX and PASSUSB. See Page 226 for details on these logs and the *Operation* chapter, in *Volume 1* of this manual set, for information on pass-through logging. See also the COMCONFIG log on Page 185.

Abbreviated ASCII Syntax:

Message ID: 3

INTERFACEMODE [port] rxtype txtype [responses]

Field	Field Type	ASCII Value	Binary Value	Description	Binary Format	Binary Bytes	Binary Offset
1	header	-	-	This field contains the command name or the message header depending on whether the command is abbreviated ASCII, ASCII or binary, respectively.	-	H	0
2	port	See Table 15, <i>COM Serial Port Identifiers</i> on Page 60		Serial port identifier (default = THISPORT)	Enum	4	H
3	rxtype	See Table 28, <i>Serial Port Interface Modes</i> on Page 88		Receive interface mode	Enum	4	H+4
4	txtype			Transmit interface mode	Enum	4	H+8
5	responses	OFF	0	Turn response generation off	Enum	4	H+12
		ON	1	Turn response generation on (default)			

ASCII Example:

```
INTERFACEMODE COM1 RTCA NOVATEL ON
```

Table 28: Serial Port Interface Modes

Binary Value	ASCII Mode Name	Description
0	NONE	The port accepts/generates nothing
1	NOVATEL	The port accepts/generates NovAtel commands and logs
2	RTCM	The port accepts/generates RTCM corrections
3	RTCA	The port accepts/generates RTCA corrections
4	CMR	The port accepts/generates CMR corrections
5	Reserved	
6		
7	IMU	This port supports communication with a NovAtel supported IMU, contact Customer Service, or refer to your <i>SPAN Technology User Manual</i> for more information
8	RTCMNOCR	RTCM with no CR/LF appended ^a
9	CDGPS	The port accepts GPS*C data ^b
10	TCOM1	<p>INTERFACEMODE tunnel modes. To configure a full duplex tunnel, configure the baud rate on each port. Once a tunnel is established, the baud rate does not change. Special characters, such as a BREAK condition, do not route across the tunnel transparently and the serial port is altered, see the COM command on <i>Page 59</i>. Only serial ports may be in a tunnel configuration: COM1, COM2, COM3 or AUX may be used.</p> <p>For example, configure a tunnel at 115200 bps between COM1 and AUX:</p> <pre>COM AUX 115200 COM COM1 115200 INTERFACEMODE AUX TCOM1 NONE OFF INTERFACEMODE COM1 TAUX NONE OFF</pre> <p>The tunnel is fully configured to receive/transmit at a baud rate of 115200 bps.</p>
11	TCOM2	
12	TCOM3	
13	TAUX	
14	RTCMV3	The port accepts/generates RTCM Version 3.0 corrections
15	NOVATELBINARY	The port only accepts/generates binary messages. If an ASCII command is entered when the mode is set to binary only, the command is ignored. Only properly formatted binary messages are responded to and the response is a binary message.

- a. An output interfacemode of RTCMNOCR is identical to RTCM but with the CR/LF appended. An input interfacemode of RTCMNOCR is identical to RTCM and functions with or without the CR/LF.
- b. CDGPS has three options for output of differential corrections - NMEA, RTCM, and GPS*C. If you have a ProPak-LB receiver, you do not need to use the INTERFACEMODE command with CDGPS as the argument. The CDGPS argument is for use with obsolete external non-NovAtel CDGPS receivers. These receivers use GPS*C (NavCanada's proprietary format differential corrections from the CDGPS service).

2.6.29 LOCKOUT Prevent the receiver from using a satellite

This command prevents the receiver from using a satellite by de-weighting its range in the solution computations. Note that the LOCKOUT command does not prevent the receiver from tracking an undesirable satellite. This command must be repeated for each satellite to be locked out.

See also the UNLOCKOUT and UNLOCKOUTALL commands.

Abbreviated ASCII Syntax:

Message ID: 137

LOCKOUT prn

Field	Field Type	ASCII Value	Binary Value	Description	Binary Format	Binary Bytes	Binary Offset
1	header	-	-	This field contains the command name or the message header depending on whether the command is abbreviated ASCII, ASCII or binary, respectively.	-	H	0
2	prn	1-37		A single satellite PRN number to be locked out.	Ulong	4	H

Input Example:

LOCKOUT 8

2.6.30 LOG Request logs from the receiver

Many different types of data can be logged using several different methods of triggering the log events. Every log element can be directed to any combination of the three COM ports and three USB ports. The ONTIME trigger option requires the addition of the *period* parameter. See *Chapter 3, Data Logs on Page 139* for further information and a complete list of data log structures. *Table 29* shows the binary command format while *Table 30* shows the ASCII command format.

The optional parameter [hold] will prevent a log from being removed when the UNLOGALL command, with its defaults, is issued. To remove a log which was invoked using the [hold] parameter requires the specific use of the UNLOG command, see *Page 131*. To remove all logs that have the [hold] parameter, use the UNLOGALL command with the *held* field set to 1, see *Page 132*.

The [port] parameter is optional. If [port] is not specified, [port] is defaulted to the port that the command was received on.

-
- ☒ 1. The OEM4 family of receivers can handle 30 logs at a time. If you attempt to log more than 30 logs at a time, the receiver will respond with an Insufficient Resources error.
 - 2. Maximum flexibility for logging data is provided to the user by these logs. The user is cautioned, however, to recognize that each log requested requires additional CPU time and memory buffer space. Too many logs may result in lost data and degraded CPU performance. Receiver overload can be monitored using the idle-time field and buffer overload bits of the Receiver Status in any log header.
 - 3. Polled log types do not allow fractional offsets and can't do ontime rates faster than 1Hz.
 - 4. Use the ONNEW trigger with the MARKTIME or MARKPOS logs.
 - 5. Only the MARKPOS log, the MARKTIME log, and 'polled' log types are generated 'on the fly' at the exact time of the mark. Synchronous and asynchronous logs will output the most recently available data.
 - 6. If you do use the ONTIME trigger with asynchronous logs, the time stamp in the log does not necessarily represent the time the data was generated, but rather the time when the log is being transmitted.
-

Abbreviated ASCII Syntax:

Message ID: 1

LOG [port] message [trigger [period [offset [hold]]]]

Table 29: LOG Command Binary Format

Field	Field Name	Binary Value	Description	Field Type	Binary Bytes	Binary Offset
1	header	(See <i>Table 4, Binary Message Header Structure on Page 17</i>)	This field contains the message header.	-	H	0
2	port	See <i>Table 15, COM Serial Port Identifiers on Page 60</i>	Output port	Enum	4	H

Continued on Page 91

3	message	Any valid message ID	Message ID of log to output	UShort	2	H+4
4	message type	Bits 0-4 = Reserved Bits 5-6 = Format 00 = Binary 01 = ASCII 10 = Abbreviated ASCII, NMEA 11 = Reserved Bit 7 = Response Bit (see <i>Section 1.2 on Page 20</i>) 0 = Original Message 1 = Response Message	Message type of log	Char	1	H+6
5	Reserved			Char	1	H+7
6	trigger	0 = ONNEW	Does not output current message but outputs when the message is updated (not necessarily changed)	Enum	4	H+8
		1 = ONCHANGED	Outputs the current message and then continue to output when the message is changed			
		2 = ONTIME	Output on a time interval			
		3 = ONNEXT	Output only the next message			
		4 = ONCE	Output only the current message			
		5 = ONMARK	Output when a pulse is detected on the mark 1 input, MK11 ^a			
7	period	Any positive double value larger than the receiver's minimum raw measurement period.	Log period (for ONTIME trigger) in seconds ^b	Double	8	H+12
8	offset	Any positive double value smaller than the period.	Offset for period (ONTIME trigger) in seconds. If you wished to log data at 1 second after every minute you would set the period to 60 and the offset to 1	Double	8	H+20
9	hold	0 = NOHOLD	Allow log to be removed by the UNLOGALL command	Enum	4	H+28
		1 = HOLD	Prevent log from being removed by the default UNLOGALL command			

- a. Refer to the *Technical Specifications* appendix in *Volume 1* of this manual set for more details on the MK11 pin. ONMARK only applies to MK11. Events on MK21 (if available) do not trigger logs when ONMARK is used.
- b. See *Appendix A* in *Volume 1* for the maximum raw measurement rate to calculate the minimum period. If the value entered is lower than the minimum measurement period, the value will be ignored and the minimum period will be used.

Table 30: LOG Command ASCII Format

Field	Field Name	ASCII Value	Description	Field Type
1	header	-	This field contains the command name or the message header depending on whether the command is abbreviated ASCII or ASCII respectively.	-
2	port	See <i>Table 15, COM Serial Port Identifiers on Page 60</i>	Output port (default = THISPORT)	Enum
3	message	Any valid message name, with an optional A or B suffix.	Message name of log to output	Char []
4	trigger	ONNEW	Output when the message is updated (not necessarily changed)	Enum
		ONCHANGED	Output when the message is changed	
		ONTIME	Output on a time interval	
		ONNEXT	Output only the next message	
		ONCE	Output only the current message. (default)	
	ONMARK	Output when a pulse is detected on the mark 1 input, MK1I (see <i>Footnote a on Page 91</i>)		
5	period	Any positive double value larger than the receiver's minimum raw measurement period.	Log period (for ONTIME trigger) in seconds (default = 0) (see <i>Footnote b on Page 91</i>)	Double
6	offset	Any positive double value smaller than the period.	Offset for period (ONTIME trigger) in seconds. If you wished to log data at 1 second after every minute you would set the period to 60 and the offset to 1 (default = 0)	Double
7	hold	NOHOLD	Allow log to be removed by the UNLOGALL command (default)	Enum
		HOLD	Prevent log from being removed by the UNLOGALL command	

Abbreviated ASCII Example 1:

```
LOG COM1 BESTPOSA ONTIME 7 2.5 HOLD
```

The above example shows the BESTPOSA log is logging to COM port 1 at 7 second intervals and offset by 2.5 seconds (output at 2.5, 9.5, 16.5 seconds and so on). The [hold] parameter is set so that logging is not disrupted by the UNLOGALL command.

To send a log only one time, the trigger option can be ignored.

Abbreviated ASCII Example 2:

```
LOG COM1 BESTPOSA ONCE 0.000000 0.000000 NOHOLD
```

See *Section 2.1, Command Formats on Page 26* for additional examples.

2.6.31 MAGVAR Set a magnetic variation correction

The receiver computes directions referenced to True North. Use this command (magnetic variation correction) if you intend to navigate in agreement with magnetic compass bearings. The correction value entered here will cause the "bearing" field of the NAVIGATE log to report bearing in degrees Magnetic. The receiver will compute the magnetic variation correction if you use the auto option. See *Figure 3, Illustration of Magnetic Variation & Correction on Page 94.*

The receiver calculates values of magnetic variation for given values of latitude, longitude and time using the International Geomagnetic Reference Field (IGRF) 95 spherical harmonic coefficients and IGRF time corrections to the harmonic coefficients.

Abbreviated ASCII Syntax:

Message ID: 180

MAGVAR type [correction] [std dev]

Field	Field Type	ASCII Value	Binary Value	Description	Binary Format	Binary Bytes	Binary Offset
1	header	-	-	This field contains the command name or the message header depending on whether the command is abbreviated ASCII, ASCII or binary, respectively.	-	H	0
2	type	AUTO	0	Use IGRF corrections	Enum	4	H
		CORRECTION	1	Use the correction supplied			
3	correction	± 180.0 degrees		Magnitude of correction (Required field if type = Correction)	Float	4	H+4
4	std_dev	± 180.0 degrees		Standard deviation of correction (default = 0)	Float	4	H+8

ASCII Example 1:

MAGVAR AUTO

ASCII Example 2:

MAGVAR CORRECTION 15 0

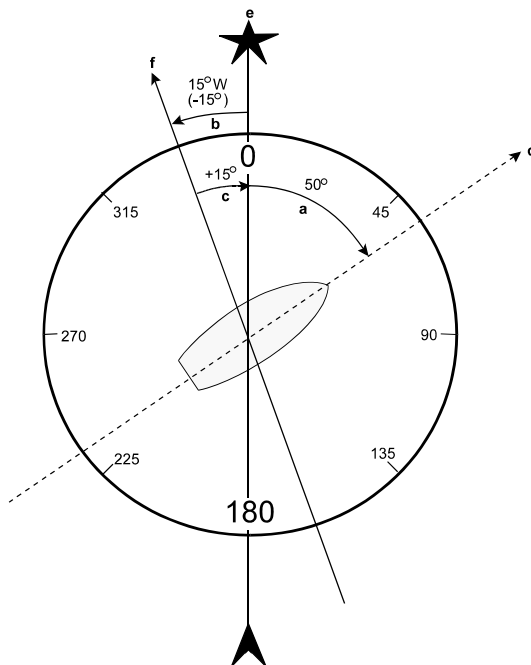
**Figure 3: Illustration of Magnetic Variation & Correction**

Reference	Description
a	True Bearing
b	Local Magnetic Variation
c	Local Magnetic Variation Correction (inverse of magnetic variation)
a + c	Magnetic Bearing
d	Heading: 50° True, 60° Magnetic
e	True North
f	Local Magnetic North

2.6.32 MARKCONTROL Control processing of mark inputs

This command provides a means of controlling the processing of the mark 1 (MK1I) and mark 2 (MK2I) inputs for the OEM4-G2 and OEM4-G2L. Using this command, the mark inputs can be enabled or disabled, the polarity can be changed, and a time offset and guard against extraneous pulses can be added.

Abbreviated ASCII Syntax:

Message ID: 614

MARKCONTROL signal switch [polarity] [timebias [timeguard]]

Field	Field Type	ASCII Value	Binary Value	Description	Binary Format	Binary Bytes	Binary Offset
1	header	-	-	This field contains the command name or the message header depending on whether the command is abbreviated ASCII, ASCII or binary, respectively.	-	H	0
2	signal	MARK1	1	Specifies which mark input the command should be applied to. Set to MARK1 for the MK1I input and MARK2 for MK2I. Both mark inputs have 10K pull-up resistors to 3.3 V and are leading edge triggered.	Enum	4	H
		MARK2	2				
3	switch	DISABLE	0	Disables or enables processing of the mark input signal for the input specified. If DISABLE is selected, the mark input signal will be ignored. The factory default is ENABLE.	Enum	4	H+4
		ENABLE	1				
4	polarity	NEGATIVE	0	Optional field to specify the polarity of the pulse to be received on the mark input. See <i>Figure 4</i> for more information. If no value is specified, the default NEGATIVE is used.	Enum	4	H+8
		POSITIVE	1				
3	timebias	Any valid long value		Optional value to specify an offset, in nanoseconds, to be applied to the time the mark input pulse occurs. If no value is supplied, the default value of 0 is used.	Long	4	H+12
4	timeguard	Any valid ulong value larger than the receiver's minimum raw measurement period. ^a		Optional field to specify a time period, in milliseconds, during which subsequent pulses after an initial pulse are ignored. If no value is supplied, the default value of 0 is used.	ULong	4	H+16

- a. See *Appendix A in Volume 1* for the maximum raw measurement rate to determine the minimum period. If the value entered is lower than the minimum measurement period, the value will be ignored and the minimum period will be used.

ASCII Example:

```
MARKCONTROL MARK1 ENABLE NEGATIVE 50 100
```

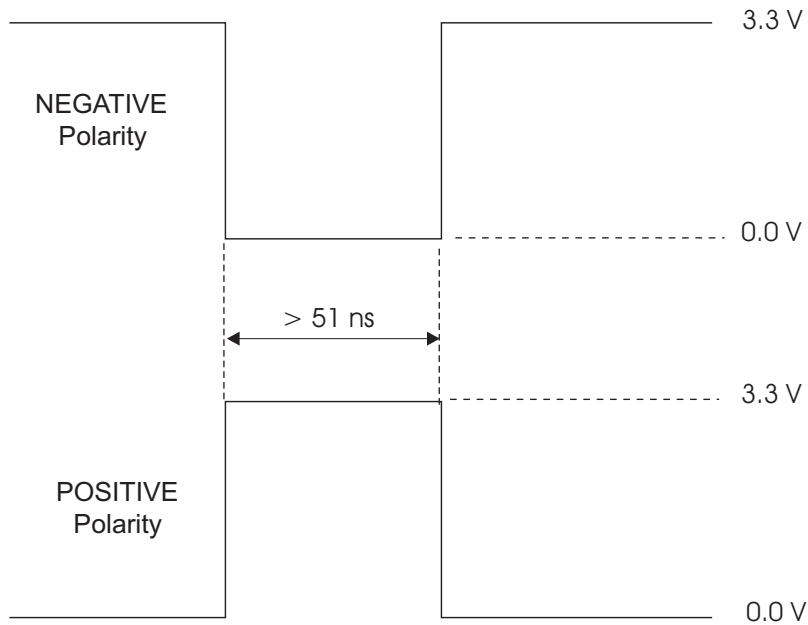

Figure 4: TTL Pulse Polarity

2.6.33 MODEL Switch to a previously authorized model

This command is used to switch the receiver between models previously added with the AUTH command. When this command is issued, the receiver will save this model as the active model. The active model will now be used on every subsequent startup. The MODEL command causes an automatic reset.

Use the VALIDMODELS log to output a list of available models for your receiver. The VALIDMODELS log is described on *Page 313*. Use the VERSION log to output the active model, see *Page 314*.

Abbreviated ASCII Syntax:

Message ID: 22

MODEL model

Field	Field Type	ASCII Value	Binary Value	Description	Binary Format	Binary Bytes	Binary Offset
1	header	-	-	This field contains the command name or the message header depending on whether the command is abbreviated ASCII, ASCII or binary, respectively.	-	H	0
2	model	Max 16 character null-terminated string (including the null)		Model name.	String [max. 16]	Vari-able ^a	Variable

a. In the binary log case additional bytes of padding are added to maintain 4 byte alignment

Input Example:

MODEL RT2W

If you switch to an expired model, the receiver will reset and enter into an error state. You will need to switch to a valid model to continue.

2.6.34 MOVINGBASESTATION *Set ability to use a moving base station*

This command enables or disables a receiver from transmitting corrections without having a fixed position. It is useful for moving base stations.

The moving base function allows you to obtain a cm level xyz baseline estimate when the base station and possibly the rover are moving. It is very similar to normal RTK, that is, one base station and potentially more than one rover depending on the data link. Communication with each receiver is done in the usual way (refer to the *Transmitting and Receiving Corrections* section of the *Operation* chapter in *Volume 1* of this manual set). The BSLNXYZ log is an asynchronous ‘matched’ log that can be logged with the onchanged trigger to provide an accurate baseline between the base and rover.

At the rover, it is recommended that you only use the PSRPOS log for position when in moving base station mode. PSRPOS also has normal accuracy with good standard deviations. Other position logs, for example BESTPOS, will have error levels of 10’s to 100’s of meters and should be considered invalid. Also, the standard deviation in these logs will not correctly reflect the error level. Other rover position logs where accuracy and standard deviations are affected by the moving base station mode are BESTXYX, GPGST, MARKPOS, MARK2POS, MATCHEDPOS, MATCHEDXYZ, RTKPOS and RTKXYZ.

The MOVINGBASESTATION command must be used to allow the base to transmit messages without a fixed position.

-
- ☒ 1. Use the PSRPOS position log at the rover. It provides the best accuracy and standard deviations when the MOVINGBASESTATION mode is enabled.
 - 2. Do not use this command with RTCM messaging.
 - 3. The MOVINGBASESTATION mode is functional if any of the following RTK message formats are in use: RTCAOBS, CMROBS, RTCAREF or CMRREF.
-

Abbreviated ASCII Syntax:

Message ID: 763

MOVINGBASESTATION switch

Field	Field Type	ASCII Value	Binary Value	Description	Binary Format	Binary Bytes	Binary Offset
1	header	-	-	This field contains the command name or the message header depending on whether the command is abbreviated ASCII, ASCII or binary, respectively.	-	H	0
2	switch	DISABLE	0	Do not transmit corrections without a fixed position (default)	Enum	4	H
		ENABLE	1	Transmit corrections without a fixed position			

ASCII Example:

```
MOVINGBASESTATION ENABLE
```

2.6.35 **NVMRESTORE** Restore NVM data after an NVM failure

This command restores non-volatile memory (NVM) data after a NVM Fail error. This failure is indicated by bit 13 of the receiver error word being set (see also *RXSTATUS*, Page 300 and *RXSTATUSEVENT*, Page 305). If corrupt NVM data is detected, the receiver will remain in the error state and continue to flash an error code on the Status LED until the NVMRESTORE command is issued (see the chapter on *Built-In Status Tests* in *Volume 1* of this manual set for further explanation).

The possibility of NVM failure is extremely remote, however, if it should occur it is likely only a small part of the data is corrupt. This command is used to remove the corrupt data and restore the receiver to an operational state. The data lost could be the user configuration, almanac, model, or other reserved information.

If you have more than one auth-code and the saved model is lost then the model may need to be entered using the MODEL command or it will be automatically saved in NVM on the next startup. If the almanac was lost, a new almanac will automatically be saved when the next complete almanac is received (after approximately 15 minutes of continuous tracking). If the user configuration was lost it will have to be re-entered by the user. This could include communication port settings.

☒ The factory default for the COM ports is 9600, n, 8, 1.

After entering the NVMRESTORE command and resetting the receiver, the communications link may have to be re-established at a different baud rate from the previous connection.

Abbreviated ASCII Syntax:

Message ID: 197

NVMRESTORE

2.6.36 PASSTOPASSMODE Enable/disable solution smoothing modes

This command allows you to enable or disable different solution smoothing modes. The command is disabled by factory default. You may decide to use it if you are using DGPS or VBS corrections. In this case, NovAtel advises that you use the recommendations shown in the table and example below.

The PASSTOPASSMODE command should only be used by advanced users of GPS.

Abbreviated ASCII Syntax:

Message ID: 601

PASSTOPASSMODE switch [measmth] [corrmth]

Field	Field Type	ASCII Value	Binary Value	Description	Binary Format	Binary Bytes	Binary Offset
1	header	-	-	This field contains the command name or the message header depending on whether the command is abbreviated ASCII, ASCII or binary, respectively.	-	H	0
2	switch	DISABLE	0	Enable or disable pass to pass smoothing mode (recommended = ENABLE)	Enum	4	H
		ENABLE	1				
3	measmth	ON	1	Enable or disable measurement smoothing mode (recommended = ON default = OFF)	Enum	4	H+4
		OFF	0				
4	corrmth	ON	1	Enable or disable correction smoothing mode (recommended = OFF default = OFF)	Enum	4	H+8
		OFF	0				
5	Reserved				Enum	4	H+12
6	Reserved				Double	8	H+16

ASCII Example for DGPS or OmniSTAR VBS:

PASSTOPASSMODE enable on off

2.6.37 POSAVE Implement base station position averaging

This command implements position averaging for base stations. Position averaging will continue for a specified number of hours or until the estimated averaged position error is within specified accuracy limits. Averaging will stop when the time limit or the horizontal standard deviation limit or the vertical standard deviation limit is achieved. When averaging is complete, the FIX POSITION command will automatically be invoked.

If you initiate differential logging, then issue the POSAVE command followed by the SAVECONFIG command the receiver will average positions after every power-on or reset, and will then invoke the FIX POSITION command to enable it to send differential corrections.

Abbreviated ASCII Syntax:

Message ID: 173

POSAVE [state] maxtime [maxhstd [maxvstd]]

Field	Field Type	ASCII Value	Binary Value	Description	Binary Format	Binary Bytes	Binary Offset
1	header	-	-	This field contains the command name or the message header depending on whether the command is abbreviated ASCII, ASCII or binary, respectively.	-	H	0
2	state	ON	1	Enable or disable position averaging. (default = ON)	Enum	4	H
		OFF	0				
3	maxtime	0.01 - 100 hours		Maximum amount of time that positions are to be averaged. Only becomes optional if State = OFF.	Float	4	H+4
4	maxhstd	0 - 100 m		Desired horizontal standard deviation. (default = 0)	Float	4	H+8
5	maxvstd	0 - 100 m		Desired vertical standard deviation. (default = 0)	Float	4	H+12

ASCII Example 1:

POSAVE 24 1 2

ASCII Example 2:

POSAVE OFF



If this command is used, its command default state is ON and as such you only need to specify the state if you wish to disable position averaging (OFF). In *Example 1* above POSAVE 24 1 2 is the same as:

POSAVE ON 24 1 2

2.6.38 **POSTIMEOUT** Sets the position time out

This commands allows you to set the time out value for the position calculation in seconds.

In position logs, for example BESTPOS or PSRPOS, when the position time out expires, the *Position Type* field is set to NONE. Other field values in these logs remain populated with the last available position data. Also, the position is no longer used in conjunction with the almanac to determine what satellites are visible.

Abbreviated ASCII Syntax:

Message ID: 612

POSTIMEOUT sec

Field	Field Type	ASCII Value	Binary Value	Description	Binary Format	Binary Bytes	Binary Offset
1	header	-	-	This field contains the command name or the message header depending on whether the command is abbreviated ASCII, ASCII or binary, respectively.	-	H	0
2	sec	0-86400		Time out in seconds Default: 600	Ulong	4	H

ASCII Example:

POSTIMEOUT 1200

2.6.39 PPSCONTROL Control the PPS output

This command provides a method for controlling the polarity and rate of the PPS output on the OEM4-G2 and OEM4-G2L receivers. The PPS output can also be disabled using this command.

Abbreviated ASCII Syntax:

Message ID: 613

PPSCONTROL switch [polarity] [rate]

Field	Field Type	ASCII Value	Binary Value	Description	Binary Format	Binary Bytes	Binary Offset
1	header	-	-	This field contains the command name or the message header depending on whether the command is abbreviated ASCII, ASCII or binary, respectively.	-	H	0
2	switch	DISABLE	0	Disables or enables output of the PPS pulse. The factory default value is ENABLE.	Enum	4	H+4
		ENABLE	1				
4	polarity	NEGATIVE	0	Optional field to specify the polarity of the pulse to be generated on the PPS output. See <i>Figure 4</i> for more information. If no value is supplied, the default NEGATIVE is used.	Enum	4	H+8
		POSITIVE	1				
3	rate	0.05, 0.1, 0.2, 0.25, 0.5, 1.0, 2.0, 3.0,...20.0		Optional field to specify the period of the pulse, in seconds. If no value is supplied, the default value of 1.0 is used.	Double	8	H+12
4	Reserved, set to 0.				ULong	4	H+20

ASCII Example:

PPSCONTROL ENABLE POSITIVE 0.5

2.6.40 PSRDIFFSOURCE Set the pseudorange correction source DGPS

This command lets you identify from which base station to accept differential corrections. This is useful when the receiver is receiving corrections from multiple base stations. See also the RTKSOURCE command on *Page 113*.

-
- ☒ 1. When a valid PSRDIFFSOURCE command is received, the current correction is removed immediately rather than waiting for the time specified in DGPSTIMEOUT, see *Page 69*.
 - 2. To use L-Band differential corrections, an L-Band receiver and a subscription to the OmniSTAR, or use of the free CDGPS, service are required. Contact NovAtel for details. Contact information may be found on the back of this manual or you can refer to the *Customer Service* section in *Volume 1* of this manual set.
-

Abbreviated ASCII Syntax:

Message ID: 493

PSRDIFFSOURCE type ID

Field	Field Type	ASCII Value	Binary Value	Description	Binary Format	Binary Bytes	Binary Offset
1	header	-	-	This field contains the command name or the message header depending on whether the command is abbreviated ASCII, ASCII or binary, respectively.	-	H	0
2	type	See <i>Table 31</i>		ID Type. All types may revert to SBAS (if enabled) or SINGLE position types. See also <i>Table 47, Position or Velocity Type</i> on <i>Page 162</i> .	Enum	4	H
3	ID	Char [5] or ANY		ID string	Char[5]	8 ^a	H+4

- a. In the binary log case an additional 3 bytes of padding are added to maintain 4 byte alignment

ASCII Examples:

1. Select only SBAS:

```
RTKSOURCE NONE
PSRDIFFSOURCE SBAS
SBASCONTROL ENABLE AUTO
```
2. Enable OmniSTAR VBS, and HP or XP:

```
RTKSOURCE OMNISTAR
PSRDIFFSOURCE OMNISTAR
```
3. Enable RTK and PSRDIFF from RTCM, with a fall-back to SBAS:

```
RTKSOURCE RTCM ANY
PSRDIFFSOURCE RTCM ANY
SBASCONTROL ENABLE AUTO
```

Table 31: DGPS Type

Binary	ASCII	Description
0	RTCM ^{a d}	RTCM ID: 0 ≤ RTCM ID ≤ 1023 or ANY
1	RTCA ^{a d}	RTCA ID: A four character string containing only alpha (a-z) or numeric characters (0-9) or ANY
2	CMR ^{a b d}	CMR ID: 0 ≤ CMR ID ≤ 31 or ANY
3	OMNISTAR ^{c d}	In the PSRDIFFSOURCE command, OMNISTAR enables OmniSTAR VBS and disables other DGPS types. OmniSTAR VBS produces RTCM-type corrections. In the RTKSOURCE command, OMNISTAR enables OmniSTAR HP (if allowed) and disables other RTK types. OmniSTAR HP has its own filter, which computes corrections in RTK float mode or within about 10 cm accuracy.
4	CDGPS ^{c d}	In the PSRDIFFSOURCE command, CDGPS enables CDGPS and disables other DGPS types. CDGPS produces SBAS-type corrections. Do not set CDGPS in the RTKSOURCE command as it can not provide carrier phase positioning and will disallow all other sources of RTK information.
5	SBAS ^{c d}	In the PSRDIFFSOURCE command, when enabled, SBAS, such as WAAS, EGNOS and MSAS, forces the use of SBAS as the pseudorange differential source. SBAS is able to simultaneously track two SBAS satellites, and incorporate the SBAS corrections into the position to generate differential-quality position solutions. An SBAS-capable receiver permits anyone within the area of coverage to take advantage of its benefits. Do not set SBAS in the RTKSOURCE command as it can not provide carrier phase positioning and will disallow all other sources of RTK information.
10	AUTO ^{c d}	In the PSRDIFFSOURCE command, AUTO means the first received RTCM or RTCA message has preference over an L-Band message. In the RTKSOURCE command, AUTO means that both the NovAtel RTK filter and the OmniSTAR HP filter (if authorized) are enabled. The NovAtel RTK filter selects the first received RTCM, RTCA, RTCMV3 or CMR message. The BESTPOS log selects the best solution between NovAtel RTK and OmniSTAR HP.
11	NONE ^{c d}	Disables all the DGPS and OMNISTAR types.
12	Reserved	
13	RTCMV3	RTCM Version 3.0 ID: 0 ≤ RTCMV3 ID ≤ 4095 or ANY

- a. Disables L-Band Virtual Base Stations (VBS)
- b. Available only with the RTKSOURCE command, see *Page 113*
- c. ID parameter is ignored
- d. All PSRDIFFSOURCE entries fall back to SBAS (even NONE) for backwards compatibility

2.6.41 **RESET** Perform a hardware reset

This command performs a hardware reset. Following a RESET command, the receiver will initiate a cold-start boot up. Therefore, the receiver configuration will revert either to the factory default if no user configuration was saved or the last SAVECONFIG settings. See also the FRESET and SAVECONFIG commands on *Pages 83 and 115* respectively.

The optional delay field is used to set the number of seconds the receiver is to wait before resetting.

Abbreviated ASCII Syntax:

Message ID: 18

RESET [delay]

Field	Field Type	ASCII Value	Binary Value	Description	Binary Format	Binary Bytes	Binary Offset
1	header	-	-	This field contains the command name or the message header depending on whether the command is abbreviated ASCII, ASCII or binary, respectively.	-	H	0
2	delay			Seconds to wait before resetting. (default = 0)	Ulong	4	H

2.6.42 RTKBASLINE Initialize RTK with a static baseline RTK

☒ This command only affects RT-2 operation and not RT-20.

This command is used in differential RTK mode to set the initial baseline information for the base station and rover station. Setting the initial baseline speeds up ambiguity resolution by indicating to the RT-2 software the exact length of the vector between the rover and base station antennas. It only affects the operation of an RT-2 system on baselines not exceeding 30 km. There are two methods of entering the baseline information: LLH and ECEF.

The first method is to use absolute LAT/LON/HEIGHT coordinates. *LAT* (in degrees) requires a decimal fraction format; a negative sign for South latitude. *Lon* (in degrees) requires a decimal fraction format; a negative sign for West longitude. *HEIGHT* (in meters) can refer either to mean sea level (default) or to an ellipsoid. The optional 2σ defines the accuracy (2 sigma, 3 dimensional) of the input position, in meters; it must be 0.03 m or less to cause the RT-2 algorithms to undergo a forced initialization to fixed integer ambiguities. If no value is entered, a default value of 0.30 m is assumed; this will not cause an initialization to occur. The optional *M* or *E* in the type field refers to the height: if “M” the height will be assumed to be above mean sea level (MSL) and if “E” the height will be ellipsoidal. Note that when an MSL height is entered, it will be converted to ellipsoidal height using the NovAtel internal undulation table or the last value entered with the “UNDULATION” command.

The other method is to use the relative ECEF vector. The $\Delta X, \Delta Y, \Delta Z$ values (in meters) represent the rover station’s position minus the base position, along each axis (in meters). The optional 2σ defines the accuracy (2 sigma, 3 dimensional) of the input baseline, in meters; it must be 0.03 m or less to cause the RT-2 algorithms to do a forced initialization to fixed integer ambiguities. If no value is entered, a default value of 0.30 m is assumed; this will not cause an initialization to occur.

Table 32: Baseline Parameters

Type	Parameter 1	Parameter 2	Parameter 3
Unknown	N/A	N/A	N/A
LLM	Lat	Lon	MSL Ht
LLE	Lat	Lon	Ellipsoidal Ht
ECEF	ΔX	ΔY	ΔZ

Abbreviated ASCII Syntax:

Message ID: 182

RTKBASLINE type [par1 par2 par3 [2sigma]]

Field	Field Type	ASCII Value	Binary Value	Description	Binary Format	Binary Bytes	Binary Offset
1	header	-	-	This field contains the command name or the message header depending on whether the command is abbreviated ASCII, ASCII or binary, respectively.	-	H	0
2	type	See <i>Table 33</i>		Set baseline type	Enum	4	H
3	par1	The baseline parameters are dependant on the type, see <i>Table 32, Baseline Parameters on Page 107</i> (They are required when the type is not UNKNOWN)			Double	8	H+4
4	par2				Double	8	H+12
5	par3				Double	8	H+20
6	2Sigma			Accuracy (2 sigma, 3 dimensional) in meters (default = 0.3 m)	Float	4	H+28

ASCII Example:

```
RTKBASLINE ECEF_BASELINE 7.54 3.28 2.02 0.25
```

Table 33: Baseline Type

ASCII	Binary	Description
UNKNOWN	0	Unknown baseline (default).
LLM_POSITION	1	Set base to lat/lon/height with MSL height
LLE_POSITION	2	Set base to lat/lon/height with Ellipsoidal height
ECEF_BASELINE	3	Set base to ECEF

2.6.43 RTKCOMMAND Reset or set the RTK filter to its defaults RTK

This command provides the ability to reset the RTK filter and clear any set RTK parameters. The RESET parameter causes the RTK algorithm (RT-20 or RT-2, whichever is active) to undergo a complete reset, forcing the system to restart the ambiguity resolution calculations. The USE_DEFAULTS command executes the following commands:

- RTKBASELINE UNKNOWN
- RTKDYNAMICS DYNAMIC
- RTKELEV MASK AUTO
- RTKSOLUTION FLOAT (RT-20)
- RTKSOLUTION FIXED (RT-2)
- RTKSVENTRIES 12

☒ See the descriptions for the above commands in the following pages.

Abbreviated ASCII Syntax:

Message ID: 97

RTKCOMMAND action

Field	Field Type	ASCII Value	Binary Value	Description	Binary Format	Binary Bytes	Binary Offset
1	header	-	-	This field contains the command name or the message header depending on whether the command is abbreviated ASCII, ASCII or binary, respectively.	-	H	0
2	type	USE_DEFAULTS	0	Reset to defaults	Enum	4	H
		RESET	1	Reset RTK algorithm			

ASCII Example:

RTKCOMMAND USE_DEFAULTS

2.6.44 RTKDYNAMICS Set the RTK dynamics mode RTK

This command provides the ability to specify how the receiver looks at the data. There are three modes: STATIC, DYNAMIC, and AUTO. The STATIC mode forces the RTK software to treat the rover station as though it were stationary, regardless of the output of the motion detector.

For reliable performance the antenna should not move more than 1-2 cm when in static mode.

DYNAMIC forces the software to treat the receiver as though it were in motion. If the receiver is undergoing very slow steady motion (<2.5 cm/sec for more than 5 seconds), you should use DYNAMIC mode (as opposed to AUTO) to prevent inaccurate results and possible resets.

On startup, the receiver defaults to the DYNAMIC setting.

Abbreviated ASCII Syntax:

Message ID: 183

RTKDYNAMICS mode

Field	Field Type	ASCII Value	Binary Value	Description	Binary Format	Binary Bytes	Binary Offset
1	header	-	-	This field contains the command name or the message header depending on whether the command is abbreviated ASCII, ASCII or binary, respectively.	-	H	0
2	mode	See Table 34		Set the dynamics mode.	Enum	4	H

ASCII Example:

```
RTKDYNAMICS DYNAMIC
```

Table 34: Dynamics Mode

ASCII	Binary	Description
AUTO	0	Automatically determine dynamics mode.
STATIC	1	Static mode.
DYNAMIC	2	Dynamic mode.

2.6.45 RTKELEV MASK Set the RTK mask angle RTK

This command sets the mask angle below which satellites will not be included. On a base station, this limits the satellites that will be transmitted in RTK observations. On a rover receiver, satellites below the mask angle will be deweighted in RTK computations.

On startup, the receiver defaults to the AUTO setting.

Abbreviated ASCII Syntax:

Message ID: 91

RTKELEV MASK type [angle]

Field	Field Type	ASCII Value	Binary Value	Description	Binary Format	Binary Bytes	Binary Offset
1	header	-	-	This field contains the command name or the message header depending on whether the command is abbreviated ASCII, ASCII or binary, respectively.	-	H	0
2	type	AUTO	0	Base - all available satellites are included Rover - elevation mask varies depending on baseline length	Enum	4	H
		USER	1	User entered angle			
3	angle	0 - 90 degrees		Elevation mask angle (required for USER setting)	Float	4	H+4

ASCII Example:

```
RTKELEV MASK USER 10.5
```

2.6.46 RTKSOLUTION Set RTK carrier phase ambiguity type RTK

This command instructs the receiver as to what type of carrier phase ambiguity (fixed, float or disable) to use. There are four settings: AUTO, L1_FLOAT, L1L2_FLOAT and DISABLE. AUTO tells the receiver to use the best ambiguity type available. For RT-2, the receiver will fix the ambiguities to discrete values whenever it can safely and reliably do so. L1_FLOAT and L1L2_FLOAT tell the receiver to only use floating point ambiguities. L2 data is required for L1L2_FLOAT. DISABLE tells the receiver to turn off RTK processing.

Abbreviated ASCII Syntax:

Message ID: 184

RTKSOLUTION type

Field	Field Type	ASCII Value	Binary Value	Description	Binary Format	Binary Bytes	Binary Offset
1	header	-	-	This field contains the command name or the message header depending on whether the command is abbreviated ASCII, ASCII or binary, respectively.	-	H	0
2	type	See Table 35		Carrier phase ambiguities type	Enum	4	H

ASCII Example:

```
RTKSOLUTION L1_FLOAT
```

Table 35: Type of Carrier Phase Ambiguity

ASCII	Binary	Description
AUTO	0	Fixed integer ambiguities for RT-2. L1_FLOAT for RT-20.
L1_FLOAT	1	L1 only floating point ambiguities.
L1L2_FLOAT	2	Dual frequency floating point ambiguities (reverts to L1_FLOAT for RT-20).
DISABLE	3	Disable RTK solutions.

2.6.47 RTKSOURCE Set the RTK correction source RTK

This command lets you identify from which base station to accept RTK (RTCM, RTCMV3, RTCA, CMR and OmniSTAR High Performance (HP)) differential corrections. This is useful when the receiver is receiving corrections from multiple base stations. See also the PSRDIFFSOURCE command on *Page 104*.

-
- ☒ To use OmniSTAR HP differential corrections, a NovAtel receiver with L-Band capability and a subscription to the OmniSTAR service are required. Contact NovAtel for details. Contact information may be found on the back of this manual or you can refer to the *Customer Service* section in *Volume 1* of this manual set.
-

Abbreviated ASCII Syntax:

Message ID: 494

RTKSOURCE type ID

Field	Field Type	ASCII Value	Binary Value	Description	Binary Format	Binary Bytes	Binary Offset
1	header	-	-	This field contains the command name or the message header depending on whether the command is abbreviated ASCII, ASCII or binary, respectively.	-	H	0
2	type	See <i>Table 31, DGPS Type on Page 105</i>		ID Type	Enum	4	H
3	ID	Char [5] or ANY		ID string	Char[5]	g ^a	H+4

- a. In the binary log case an additional 3 bytes of padding are added to maintain 4 byte alignment

ASCII Examples:

1. Select only SBAS:

```
RTKSOURCE NONE
PSRDIFFSOURCE NONE
SBASCONTROL ENABLE AUTO
```
2. Enable OmniSTAR HP and VBS:

```
RTKSOURCE OMNISTAR
PSRDIFFSOURCE OMNISTAR
```
3. Enable RTK and PSRDIF from RTCM, with a fall-back to SBAS:

```
RTKSOURCE RTCM ANY
PSRDIFFSOURCE RTCM ANY
SBASCONTROL ENABLE AUTO
```

2.6.48 RTKSVENTRIES Set number of satellites in corrections RTK

This command sets the number of satellites (at the highest elevation) that will be transmitted in the RTK corrections from a base station receiver. This is useful when the amount of bandwidth available for transmitting corrections is limited.

Abbreviated ASCII Syntax:

Message ID: 92

RTKSVENTRIES number

Field	Field Type	ASCII Value	Binary Value	Description	Binary Format	Binary Bytes	Binary Offset
1	header	-	-	This field contains the command name or the message header depending on whether the command is abbreviated ASCII, ASCII or binary, respectively.	-	H	0
2	number	4-12		The number of SVs to use in the solution (default = 12)	ULong	4	H

ASCII Example:

```
RTKSVENTRIES 7
```

2.6.49 **SAVECONFIG** *Save current configuration in NVM*

This command saves your present configuration in non-volatile memory. The configuration includes the current log settings, FIX settings, port configurations, and so on. Its output is in the RXCONFIG log, see *Page 297*. See also the FRESET command, *Page 83*.

Abbreviated ASCII Syntax:

Message ID: 19

SAVECONFIG

WARNING!: If you are using this command in GPSolution, ensure that you have all windows other than the Console window closed. Otherwise, log commands used for the various windows will be saved as well. This will result in unnecessary data being logged.

2.6.50 SBASCONTROL Set SBAS test mode and PRN SBAS

This command allows you to dictate how the receiver handles Satellite Based Augmentation System (SBAS) corrections and replaces the now obsolete WAASCORRECTION command. The receiver automatically switches to Pseudorange Differential (RTCM or RTCA) or RTK if the appropriate corrections are received, regardless of the current setting.

To enable the position solution corrections, you must issue the SBASCONTROL ENABLE command. The GPS receiver does not attempt to track any GEO satellites until you use the SBASCONTROL command to tell it to use either WAAS, EGNOS, or MSAS corrections.

When in AUTO mode, if the receiver is outside the defined satellite system's corrections grid, it reverts to ANY mode and chooses a system based on other criteria.

Once tracking satellites from one system in ANY or AUTO mode, it does not track satellites from other systems. This is because systems such as WAAS, EGNOS and MSAS do not share broadcast information and have no way of knowing each other are there.

The "testmode" parameter in the example is to get around the test mode of these systems. EGNOS at one time used the IGNOREZERO test mode. At the time of printing, ZEROTOTWO is the correct setting for all SBAS, including EGNOS, running in test mode. On a simulator, you may want to leave this parameter off or specify NONE explicitly.

When you use the SBASCONTROL command to direct the GPS receiver to use a specific correction type, the GPS receiver begins to search for and track the relevant GEO PRNs for that correction type only.

You can force the GPS receiver to track a specific PRN using the ASSIGN command. You can force the GPS receiver to use the corrections from a specific SBAS PRN using the SBASCONTROL command.

Disable stops the corrections from being used.

Abbreviated ASCII Syntax:

Message ID: 652

SBASCONTROL keyword [system] [prn] [testmode]

Field	Field Type	ASCII Value	Binary Value	Description	Binary Format	Binary Bytes	Binary Offset
1	header	-	-	This field contains the command name or the message header depending on whether the command is abbreviated ASCII, ASCII or binary, respectively.	-	H	0
2	keyword	ENABLE	0	Receiver will use the SBAS corrections it receives.	Enum	4	H
		DISABLE	1	Receiver will not use the SBAS corrections it receives.			
3	system	See Table 36 on Page 117		Choose the SBAS the receiver will use	Enum	4	H+4

Continued on Page 117

4	prn	0		Receiver will use any PRN. (default)	ULong	4	H+8
		120-138		Receiver will use SBAS corrections only from this PRN			
5	testmode	NONE	0	Receiver will interpret Type 0 messages as they are intended (as do not use). (default)	Enum	4	H+12
		ZEROTOTWO	1	Receiver will interpret Type 0 messages as Type 2 messages			
		IGNOREZERO	2	Receiver will ignore the usual interpretation of Type 0 messages (as do not use) and continue			

Table 36: System Types

ASCII	Binary	Description
NONE	0	Don't use any SBAS satellites
AUTO	1	Automatically determine satellite system to use (default)
ANY	2	Use any and all SBAS satellites found
WAAS	3	Use only WAAS satellites
EGNOS	4	Use only EGNOS satellites
MSAS	5	Use only MSAS satellites

Abbreviated ASCII Example 1:

SBASCONTROL ENABLE WAAS 0 ZEROTOTWO

2.6.51 SEND Send an ASCII message to a COM port

This command is used to send ASCII printable data from any of the COM or USB ports to a specified communications port. This is a one-time command, therefore the data message must be preceded by the SEND command and followed by <CR> each time you wish to send data. If the data string contains delimiters (that is, spaces, commas, tabs, and so on), the entire string must be contained within double quotation marks. Carriage return and line feed characters (for example, 0x0D, 0x0A) are appended to the sent ASCII data.

Abbreviated ASCII Syntax:

Message ID: 177

SEND port data

Field	Field Type	ASCII Value	Binary Value	Description	Binary Format	Binary Bytes	Binary Offset
1	header	-	-	This field contains the command name or the message header depending on whether the command is abbreviated ASCII, ASCII or binary, respectively.	-	H	0
2	port	See <i>Table 15, COM Serial Port Identifiers</i> on Page 60		Output port	Enum	4	H
3	message	Max 100 character string		ASCII data to send	String [max. 100]	Variable ^a	Variable

- a. In the binary log case additional bytes of padding are added to maintain 4 byte alignment

Scenario: Assume that you are operating receivers as base and rover stations. It could also be assumed that the base station is unattended but operational and you wish to control it from the rover station. From the rover station, you could establish the data link and command the base station receiver to send differential corrections.

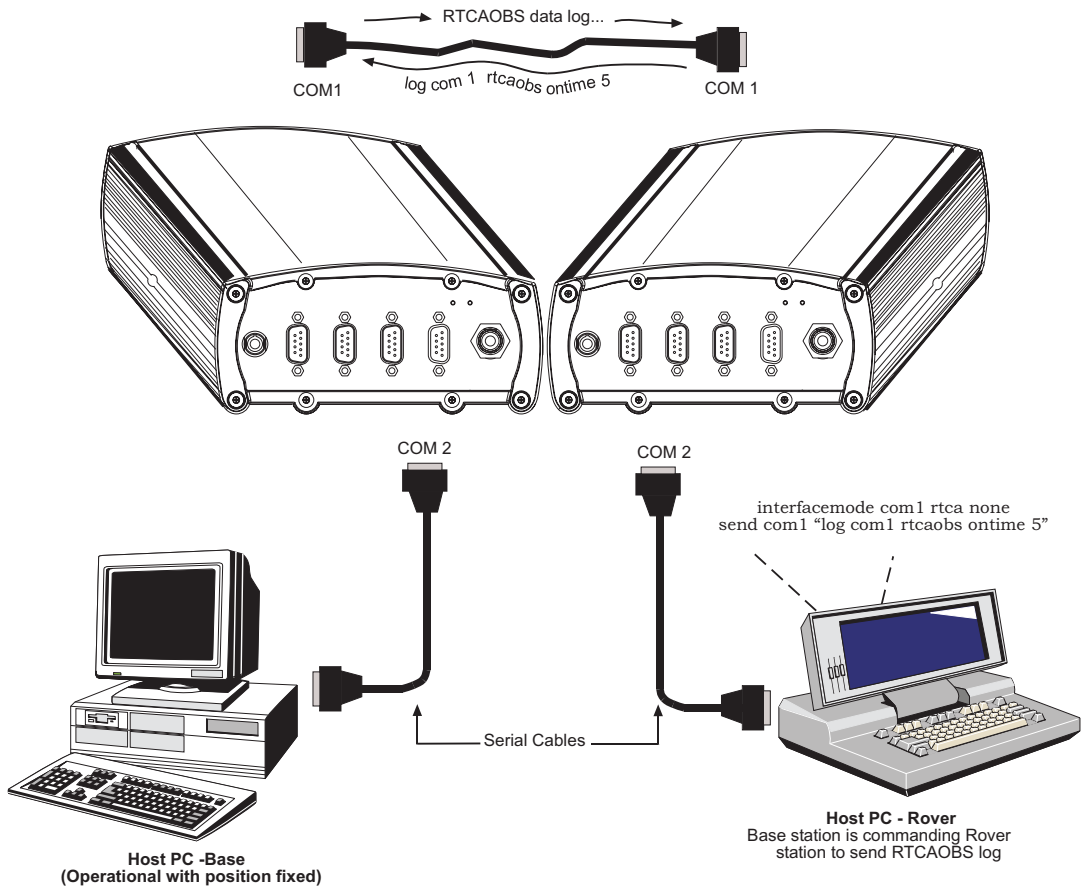

Figure 5: Using the SEND Command

2.6.52 SENDHEX Send non-printable characters in hex pairs

This command is like the SEND command except that it is used to send non-printable characters expressed as hexadecimal pairs. Carriage return and line feed characters (for example, 0x0D, 0x0A) will **not** be appended to the sent data and so must be explicitly added to the data if needed.

Abbreviated ASCII Syntax:

Message ID: 178

SENDHEX port length data

Field	Field Type	ASCII Value	Binary Value	Description	Binary Format	Binary Bytes	Binary Offset
1	header	-	-	This field contains the command name or the message header depending on whether the command is abbreviated ASCII, ASCII or binary, respectively.	-	H	0
2	port	See <i>Table 15, COM Serial Port Identifiers on Page 60</i>		Output port	Enum	4	H
3	length	0 - 700		Number of hex pairs	ULong	4	H+4
4	message	limited to a 700 maximum string (1400 pair hex) by command interpreter buffer <ul style="list-style-type: none"> • even number of ASCII characters from set of 0-9, A-F • no spaces are allowed between pairs of characters 		Data	String [max. 700]	Vari-able ^a	Variable

- a. In the binary log case additional bytes of padding are added to maintain 4 byte alignment

Input Example:

```
sendhex COM1 6 143Ab5910D0A
```

2.6.53 SETAPPROXPOS Set an approximate position

This command sets an approximate latitude, longitude, and height in the receiver. Estimating these parameters, when used in conjunction with an approximate time (see the SETAPPROXTIME command on *Page 122*), can improve satellite acquisition times and time to first fix. For more information, please refer to the *TTF and Satellite Acquisition* section of the *GPS+ Reference Manual* available on our website at <http://www.novatel.com/support/docupdates.htm>.

The horizontal position entered should be within 200 km of the actual receiver position. The approximate height is not critical and can normally be entered as zero. If the receiver cannot calculate a valid position within 2.5 minutes of entering an approximate position, the approximate position is ignored.

The approximate position is not visible in any position logs. It can be seen by entering a LOG SETAPPROXPOS message. See also the SATVIS log on *Page 307*.

Abbreviated ASCII Syntax:

Message ID: 377

SETAPPROXPOS lat lon height

Field	Field Type	ASCII Value	Binary Value	Description	Binary Format	Binary Bytes	Binary Offset
1	header	-	-	This field contains the command name or the message header depending on whether the command is abbreviated ASCII, ASCII or binary, respectively.	-	H	0
2	Lat	± 90 degrees		Approximate latitude	Double	8	H
3	Lon	± 360 degrees		Approximate longitude	Double	8	H+8
4	Height	-1000 to +20000000 m		Approximate geoidal height	Double	8	H+16

Input Example:

```
setapproxpos 51.116 -114.038 0
```

2.6.54 SETAPPROXTIME Set an approximate GPS time

This command sets an approximate time in the receiver. The receiver will use this time as a system time until a GPS coarse time can be acquired. This can be used in conjunction with an approximate position (see the SETAPPROXPOS command on *Page 121*) to improve time to first fix. For more information, please refer to the *TTF and Satellite Acquisition* section of the *GPS+ Reference Manual* available on our website at <http://www.novatel.com/support/docupdates.htm>.

The time entered should be within 10 minutes of the actual GPS time.

If the week number entered does not match the broadcast week number, the receiver resets.

See also the SATVIS log on *Page 307*.

Abbreviated ASCII Syntax:

Message ID: 102

SETAPPROXTIME week sec

Field	Field Type	ASCII Value	Binary Value	Description	Binary Format	Binary Bytes	Binary Offset
1	header	-	-	This field contains the command name or the message header depending on whether the command is abbreviated ASCII, ASCII or binary, respectively.	-	H	0
2	week	0-9999		GPS week number	Ulong	4	H
3	sec	0-604801		Number of seconds into GPS week	Double	8	H+4

Input Example:

```
setapproxtime 1105 425384
```

2.6.55 SETNAV Set start and destination waypoints

This command permits entry of one set of navigation waypoints (see *Figure 6 on Page 124*). The origin (FROM) and destination (TO) waypoint coordinates entered are considered on the ellipsoidal surface of the current datum (default WGS84). Once SETNAV has been set, you can monitor the navigation calculations and progress by observing the NAVIGATE log messages.

Track offset is the perpendicular distance from the great circle line drawn between the FROM lat-lon and TO lat-lon waypoints. It establishes the desired navigation path, or track, that runs parallel to the great circle line, which now becomes the offset track, and is set by entering the track offset value in meters. A negative track offset value indicates that the offset track is to the left of the great circle line track. A positive track offset value (no sign required) indicates the offset track is to the right of the great circle line track (looking from origin to destination). See *Figure 6 on Page 124* for clarification.

Abbreviated ASCII Syntax:

Message ID: 162

SETNAV fromlat fromlon tolat tolon track offset from-point to-point

Field	Field Type	ASCII Value	Binary Value	Description	Binary Format	Binary Bytes	Binary Offset
1	header	-	-	This field contains the command name or the message header depending on whether the command is abbreviated ASCII, ASCII or binary, respectively.	-	H	0
2	fromlat	± 90 degrees		Origin latitude in units of degrees/decimal degrees. A negative sign for South latitude. No sign for North latitude.	Double	8	H
3	fromlon	± 360 degrees		Origin longitude in units of degrees/decimal degrees. A negative sign for West longitude. No sign for East longitude.	Double	8	H+8
4	tolat	± 90 degrees		Destination latitude in units of degrees/decimal degrees.	Double	8	H+16
5	tolon	± 360 degrees		Destination longitude in units of degrees/decimal degrees.	Double	8	H+24
6	track offset	± 1000 km		Waypoint great circle line offset (in kilometers); establishes offset track; positive indicates right of great circle line; negative indicates left of great circle line.	Double	8	H+32
7	from-point	6 characters max.		ASCII station name	String [max. 6]	Variable ^a	Variable
8	to-point	6 characters max.		ASCII station name	String [max. 6]	Variable ^a	Variable

a. In the binary log case additional bytes of padding are added to maintain 4 byte alignment

ASCII Example:

```
SETNAV 51.1516 -114.16263 51.16263 -114.1516 -125.23 FROM TO
```

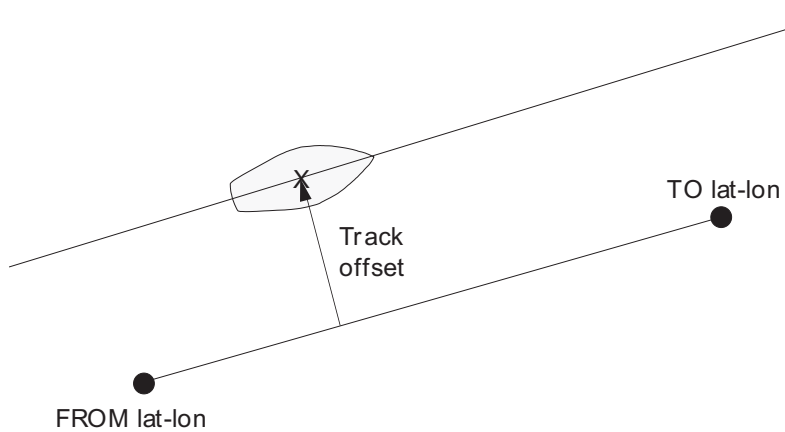
**Figure 6: Illustration of SETNAV Parameters**

2.6.56 SETRTCM16 Enter ASCII text for RTCM data stream DGPS/RTK

The RTCM type 16 message allows ASCII text to be transferred from a GPS base station to rover GPS receivers. The SETRTCM16 command is used to define the ASCII text at the base station. The text defined by the SETRTCM16 command can be verified in the RXCONFIG log. Once the ASCII text is defined it can be broadcast periodically by the base station with the command "log port RTCM16 ONTIME interval". The received ASCII text can be displayed at the rover by logging RTCM16T.

This command will limit the input message length to a maximum of 90 ASCII characters. If the message string contains any delimiters (that is, spaces, commas, tabs, and so on) the entire string must be contained in double quotation marks.

Abbreviated ASCII Syntax:

Message ID: 131

SETRTCM16 text

Field	Field Type	ASCII Value	Binary Value	Description	Binary Format	Binary Bytes	Binary Offset
1	header	-	-	This field contains the command name or the message header depending on whether the command is abbreviated ASCII, ASCII or binary, respectively.	-	H	0
2	text	Max 90 character string		The text string	String [max. 90]	Variable ^a	Variable

a. In the binary log case additional bytes of padding are added to maintain 4 byte alignment

Input Example:

SETRTCM16 "Base station will shut down in 1 hour"

2.6.57 STATUSCONFIG Configure RXSTATUSEVENT mask fields

This command is used to configure the various status mask fields in the RXSTATUSEVENT log, see *Page 305*. These masks allow you to modify whether various status fields generate errors or event messages when they are set or cleared.

The receiver gives the user the ability to determine the importance of the status bits. In the case of the Receiver Status, setting a bit in the priority mask will cause the condition to trigger an error. This will cause the receiver to idle all channels, set the ERROR strobe line, flash an error code on the status LED, turn off the antenna (LNA power), and disable the RF hardware, the same as if a bit in the Receiver Error word is set. Setting a bit in an Auxiliary Status priority mask will cause that condition to set the bit in the Receiver Status word corresponding to that Auxiliary Status.

Receiver Errors automatically generate event messages. These event messages are output in RXSTATUSEVENT logs. It is also possible to have status conditions trigger event messages to be generated by the receiver. This is done by setting/clearing the appropriate bits in the event set/clear masks. The set mask tells the receiver to generate an event message when the bit becomes set. Likewise, the clear mask causes messages to be generated when a bit is cleared. If you wish to disable all these messages without changing the bits, simply UNLOG the RXSTATUSEVENT logs on the appropriate ports. Refer also to the *Built in Status Tests* chapter in *Volume 1* of this manual set.

Abbreviated ASCII Syntax:

Message ID: 95

STATUSCONFIG type word mask

Field	Field Type	ASCII Value	Binary Value	Description	Binary Format	Binary Bytes	Binary Offset
1	header	-	-	This field contains the command name or the message header depending on whether the command is abbreviated ASCII, ASCII or binary, respectively.	-	H	0
2	type	See <i>Table 37</i>		Type of mask to replace	Enum	4	H
3	word	STATUS	1	Receiver Status word	Enum	4	H+4
		AUX1	2	Auxiliary 1 Status word			
4	mask	8 digit hexadecimal		The hexadecimal bit mask	Ulong	4	H+8

ASCII Example:

```
STATUSCONFIG SET STATUS 0028A51D
```

Table 37: Mask Types

ASCII	Binary	Description
PRIORITY	0	Replace the Priority mask
SET	1	Replace the Set mask
CLEAR	2	Replace the Clear mask

2.6.58 UNASSIGN *Unassign a previously assigned channel*

This command cancels a previously issued ASSIGN command and the SV channel reverts to automatic control (the same as ASSIGN AUTO).

Abbreviated ASCII Syntax:

Message ID: 29

UNASSIGN channel

Field	Field Type	ASCII Value	Binary Value	Description	Binary Format	Binary Bytes	Binary Offset
1	header	-	-	This field contains the command name or the message header depending on whether the command is abbreviated ASCII, ASCII or binary, respectively.	-	H	0
2	channel	0-11		Reset SV channel to automatic search and acquisition mode	ULong	4	H
3	state	See Table 12, Channel State on Page 47		Set the SV channel state (currently ignored)	Enum	4	H+4

Input Example:

```
unassign 11
```

2.6.59 UNASSIGNALL *Unassign all previously assigned channels*

This command cancels all previously issued ASSIGN commands for all SV channels (same as ASSIGNALL AUTO). Tracking and control for each SV channel reverts to automatic mode. See ASSIGN AUTO for more details.

Abbreviated ASCII Syntax:

Message ID: 30

UNASSIGNALL [system]

Field	Field Type	ASCII Value	Binary Value	Description	Binary Format	Binary Bytes	Binary Offset
1	header	-	-	This field contains the command name or the message header depending on whether the command is abbreviated ASCII, ASCII or binary, respectively.	-	H	0
2	system	See Table 13, Channel System on Page 50		System that the SV channel is tracking.	Enum	4	H

Input Example:

```
unassignall GPSL1
```

2.6.60 UNDULATION Choose undulation

This command permits you to either enter a specific geoidal undulation value or use the internal table of geoidal undulations. In the *option* field, the EGM96 table provides ellipsoid heights at a 0.25° by 0.25° spacing while the OSU89B is implemented at a 2° by 3° spacing. In areas of rapidly changing elevation, you could be operating somewhere within the 2° by 3° grid with an erroneous height. EGM96 provides a more accurate model of the ellipsoid which results in a denser grid of heights. It is more accurate because the accuracy of the grid points themselves has also improved from OSU89B to EGM96. For example, the new grid would be useful where there are underwater canyons, steep drop-offs or mountains.

The undulation values reported in the BESTPOS, BESTUTM, MARKPOS, MATCHEDPOS, OMNIHPPPOS, PSRPOS and RTKPOS logs are in reference to the ellipsoid of the chosen datum.

Abbreviated ASCII Syntax:

Message ID: 214

UNDULATION option [separation]

Field	Field Type	ASCII Value	Binary Value	Description	Binary Format	Binary Bytes	Binary Offset
1	header	-	-	This field contains the command name or the message header depending on whether the command is abbreviated ASCII, ASCII or binary, respectively.	-	H	0
2	option	TABLE	0	Use the internal undulation table (default) (same as OSU89B)	Enum	4	H
		USER	1	Use the user specified undulation value			
		OSU89B	2	Use the OSU89B undulation table			
		EGM96	3	Use the geoidal height model EGM96 table			
3	separation	± 1000.0 m		The undulation value (required for the USER option)	Float	4	H+4

ASCII Example 1:

UNDULATION TABLE

ASCII Example 2:

UNDULATION USER -5.599999905

Please refer to the *GPS Overview* section of the *GPS+ Reference Manual* available on our website at <http://www.novatel.com/support/docupdates.htm> for a description of the relationships in *Figure 7* below.

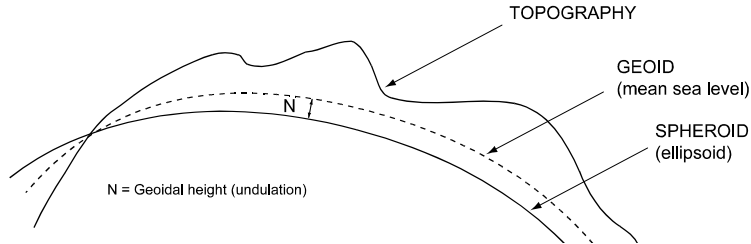

Figure 7: Illustration of Undulation

2.6.61 UNLOCKOUT *Reinstate a satellite in the solution*

This command allows a satellite which has been previously locked out (LOCKOUT command) to be reinstated in the solution computation. If more than one satellite is to be reinstated, this command must be reissued for each satellite reinstatement.

Abbreviated ASCII Syntax:

Message ID: 138

UNLOCKOUT prn

Field	Field Type	ASCII Value	Binary Value	Description	Binary Format	Binary Bytes	Binary Offset
1	header	-	-	This field contains the command name or the message header depending on whether the command is abbreviated ASCII, ASCII or binary, respectively.	-	H	0
2	prn	1-37		A single satellite PRN number to be reinstated.	Ulong	4	H

Input Example:

```
unlockout 8
```

2.6.62 UNLOCKOUTALL *Reinstate all previously locked out satellites*

This command allows all satellites which have been previously locked out (LOCKOUT command) to be reinstated in the solution computation.

Abbreviated ASCII Syntax:

Message ID: 139

UNLOCKOUTALL

Input Example:

```
unlockoutall
```

2.6.63 UNLOG Remove a log from logging control

This command permits you to remove a specific log request from the system.

The [port] parameter is optional. If [port] is not specified, it is defaulted to the port on which the command was received. This feature eliminates the need for you to know which port you are communicating on if you want logs to be removed on the same port as this command.

Abbreviated ASCII Syntax:

Message ID: 36

UNLOG [port] datatype

Table 38: UNLOG Command ASCII Format

Field	Field Type	ASCII Value	Binary Value	Description	Binary Format	Binary Bytes	Binary Offset
1	header	-	-	This field contains the command name or the message header depending on whether the command is abbreviated ASCII, ASCII or binary, respectively.	-	H	0
2	port	See Table 5 on Page 18 (decimal values greater than 16 may be used)		Port to which log is being sent. (default = THISPORT)	Enum	4	H
3	message	Message Name	N/A	Message Name of log to be disabled.	ULong	4	H+4

Table 39: UNLOG Command Binary Format

Field	Field Name	Binary Value	Description	Field Type	Binary Bytes	Binary Offset
1	header	(See Table 4, Binary Message Header Structure on Page 17)	This field contains the message header.	-	H	0
2	port	See Table 5 on Page 18 (decimal values greater than 16 may be used)	Port to which log is being sent. (default = THISPORT)	Enum	4	H
3	message	Any valid message ID	Message ID of log to output	UShort	2	H+4
4	message type	Bits 0-4 = Reserved Bits 5-6 = Format 00 = Binary 01 = ASCII 10 = Abbreviated ASCII, NMEA 11 = Reserved Bit 7 = Response Bit (see Section 1.2 on Page 20) 0 = Original Message 1 = Response Message	Message type of log	Char	1	H+6
5	Reserved			Char	1	H+7

Input Example:

```
unlog com1 bestposa
unlog bestposa
```

2.6.64 UNLOGALL *Remove all logs from logging control*

If [*port*] is specified this command disables all logs on the specified port only. All other ports are unaffected. If [*port*] is not specified this command defaults to the ALLPORTS setting.

Abbreviated ASCII Syntax:

Message ID: 38

UNLOGALL [*port*]

Field	Field Type	ASCII Value	Binary Value	Description	Binary Format	Binary Bytes	Binary Offset
1	header	-	-	This field contains the command name or the message header depending on whether the command is abbreviated ASCII, ASCII or binary, respectively.	-	H	0
2	port	See <i>Table 5 on Page 18</i> (decimal values greater than 16 may be used)		Port to clear. (default = ALLPORTS)	Enum	4	H
3	held	FALSE	0	Does not remove logs with the HOLD parameter (default)	Enum	4	H+4
		TRUE	1	Removes previously held logs, even those with the HOLD parameter			

Input Example:

```
unlogall com2_15
```

2.6.65 USERDATUM Set user-customized datum

This command permits entry of customized ellipsoidal datum parameters. This command is used in conjunction with the DATUM command, see *Page 64*. If used, the command default setting for USERDATUM is WGS84.

When the USERDATUM command is entered, the USEREXPDATUM command, see *Page 134*, is then issued internally with the USERDATUM command values. It is the USEREXPDATUM command that appears in the RXCONFIG log. If the USEREXPDATUM or the USERDATUM command are used, their newest values overwrite the internal USEREXPDATUM values.

The transformation for the WGS84 to Local used in the OEM4 family is the Bursa-Wolf transformation or reverse Helmert transformation. In the Helmert transformation, the rotation of a point is counterclockwise around the axes. In the Bursa-Wolf transformation, the rotation of a point is clockwise. Therefore, the reverse Helmert transformation is the same as the Bursa-Wolf.

Abbreviated ASCII Syntax:

Message ID: 78

USERDATUM semimajor flattening dx dy dz rx ry rz scale

Field	Field Type	ASCII Value	Binary Value	Description	Binary Format	Binary Bytes	Binary Offset
1	header	-	-	This field contains the command name or the message header depending on whether the command is abbreviated ASCII, ASCII or binary, respectively.	-	H	0
2	semimajor	6300000.0 - 6400000.0 m		Datum Semi-major Axis (a) in meters	Double	8	H
3	flattening	290.0 - 305.0		Reciprocal Flattening, $1/f = a/(a-b)$	Double	8	H+8
4	dx	± 2000.0		Datum offsets from WGS84. These will be the translation values between the user datum and WGS84 (internal reference)	Double	8	H+16
5	dy	± 2000.0			Double	8	H+24
6	dz	± 2000.0			Double	8	H+32
7	rx	± 10.0 radians		Datum Rotation Angle about X, Y and Z axis. These values will be the rotation from WGS84 to your datum. A positive sign is for clockwise rotation and a negative sign is for counter clockwise rotation.	Double	8	H+40
8	ry	± 10.0 radians			Double	8	H+48
9	rz	± 10.0 radians			Double	8	H+56
10	scale	± 10.0 ppm		Scale value is the difference in ppm between the user datum and WGS84	Double	8	H+64

ASCII Example:

```
USERDATUM 6378206.400 294.97869820000 -12.0000 147.0000
192.0000 0.0000 0.0000 0.0000 0.000000000
```

2.6.66 USEREXPDATUM Set custom expanded datum

Like the USERDATUM command, this command allows you to enter customized ellipsoidal datum parameters. However, USEREXPDATUM literally means user expanded datum allowing you to enter additional datum information such as velocity offsets and time constraints. The 7 expanded parameters are rates of change of the initial 7 parameters. These rates of change affect the initial 7 parameters over time relative to the Reference Date provided by the user.

This command is used in conjunction with the datum command, see *Page 63*. If you use this command without specifying any parameters, the command defaults to WGS84. If you enter a USERDATUM command, see *Page 133*, the USEREXPDATUM command is then issued internally with the USERDATUM command values. It is the USEREXPDATUM command that appears in the RXCONFIG log. If the USEREXPDATUM or the USERDATUM command are used, their newest values overwrite the internal USEREXPDATUM values.

Abbreviated ASCII Syntax:

Message ID: 783

USEREXPDATUM semimajor flattening dx dy dz rx ry rz scale xvel yvel zvel xrvel yrvel zrvel scalev refdate

Field	Field Type	ASCII Value	Binary Value	Description	Binary Format	Binary Bytes	Binary Offset
1	header	-	-	This field contains the command name or the message header depending on whether the command is abbreviated ASCII, ASCII or binary, respectively.	-	H	0
2	semimajor	6300000.0 - 6400000.0 m		Datum semi-major axis (a) in meters	Double	8	H
3	flattening	290.0 - 305.0		Reciprocal Flattening, $1/f = a/(a-b)$	Double	8	H+8
4	dx	± 2000.0 m		Datum offsets from WGS84. These will be the translation values between the user datum and WGS84 (internal reference)	Double	8	H+16
5	dy	± 2000.0 m			Double	8	H+24
6	dz	± 2000.0 m			Double	8	H+32
7	rx	± 10.0 radians		Datum rotation angle about X, Y and Z. These values will be the rotation from WGS84 to your datum. A positive sign for clockwise rotation and a negative sign for counter clockwise rotation.	Double	8	H+40
8	ry	± 10.0 radians			Double	8	H+48
9	rz	± 10.0 radians			Double	8	H+56
10	scale	± 10.0 ppm		Scale value is the difference in ppm between the user datum and WGS84	Double	8	H+64
11	xvel	± 2000.0 m/yr		Velocity vector along X-axis	Double	8	H+72
12	yvel	± 2000.0 m/yr		Velocity vector along Y-axis	Double	8	H+80
13	zvel	± 2000.0 m/yr		Velocity vector along Z-axis	Double	8	H+88
14	xrvel	± 10.0 radians/yr		Change in the rotation about X over time	Double	8	H+96
15	yrvel	± 10.0 radians/yr		Change in the rotation about Y over time	Double	8	H+104
16	zrvel	± 10.0 radians/yr		Change in the rotation about Z over time	Double	8	H+112
17	scalev	± 10.0 ppm/yr		Change in scale from WGS84 over time	Double	8	H+120
18	refdate	0.0 year		Reference date of parameters Example: 2005.00 = Jan 1, 2005 2005.19 = Mar 11, 2005	Double	8	H+128

ASCII Example:

```
USEREXPDATUM 6378137.000 298.25722356280 0.000000000 0.000000000 0.000000000
0.00000000 0 0.000000000 0.000000000 0.000000000 0.000000000 0.000000000
0.000000000 0.0000 00000 0.000000000 0.000000000 0.000000000 0.000000000
```

2.6.67 UTMZONE Set UTM parameters

This command sets the UTM persistence, zone number or meridian. Please refer to <http://earth-info.nga.mil/GandG/coordsys/grids/grid1.htm> for more information and a world map of UTM zone numbers.

Abbreviated ASCII Syntax:

Message ID: 749

UTMZONE command parameter

Field	Field Type	ASCII Value	Binary Value	Description	Binary Format	Binary Bytes	Binary Offset
1	header	-	-	This field contains the command name or the message header depending on whether the command is abbreviated ASCII, ASCII or binary, respectively.	-	H	0
2	command	See Table 40 below			Enum	4	H
3	parameter				Enum	4	H+4

-
- ☒ 1. The latitude limits of the UTM System are 80°S to 84°N, so if your position is outside this range, the BESTUTM log outputs a northing, easting, and height of 0.0, along with a zone letter of “*” and a zone number of 0, so that it is obvious that the data in the log is dummy data.
 - 2. If the latitude band is X, then the Zone number should not be set to 32, 34 or 36. These zones were incorporated into other zone numbers and do not exist.
-

Table 40: UTM Zone Commands

Binary	ASCII	Description
0	AUTO	UTM zone default that automatically sets the central meridian and does not switch zones until it overlaps by the set persistence. This a spherical approximation to the earth unless you are at the equator. (default = 0) (m)
1	CURRENT	Same as UTMZONE AUTO with infinite persistence of the current zone. The parameter field is not used.
2	SET	Sets the central meridian based on the specified UTM zone. A zone includes its western boundary, but not its eastern boundary, Meridian. For example, zone 12 includes (108°W, 114°W] where $108^\circ < \text{longitude} \leq 114^\circ$.
3	MERIDIAN	Sets the central meridian as specified in the parameter field. In BESTUTM, the zone number is output as 61 to indicate the manual setting (zones are set by pre-defined central meridians not user-set ones).

ASCII Example 1:

```
UTMZONE SET 10
```

ASCII Example 2:

```
UTMZONE CURRENT
```

2.6.68 WAASCORRECTION SBAS

This command is obsolete and has been superseded by the SBASCONTROL command, see *Page 116*. As such, it is supported in this and previous revisions of the firmware but may not be in future revisions.

Abbreviated ASCII Syntax:

Message ID: 312

WAASCORRECTION keyword [prn[mode]]

Field	Field Type	ASCII Value	Binary Value	Description	Binary Format	Binary Bytes	Binary Offset
1	header	-	-	This field contains the command name or the message header depending on whether the command is abbreviated ASCII, ASCII or binary, respectively.	-	H	0
2	keyword	ENABLE	0	Receiver will use the SBAS corrections it receives.	Enum	4	H
		DISABLE	1	Receiver will not use the SBAS corrections it receives.			
3	prn	0		Receiver will use any PRN. (default)	ULong	4	H+4
		120-138		Receiver will use SBAS corrections only from this PRN.			
4	mode	NONE	0	Receiver will interpret Type 0 messages as they are intended (as do not use). (default)	Enum	4	H+8
		WAATESTMODE	1	Receiver will interpret Type 0 messages as Type 2 messages.			
		EGNOSTESTMODE	2	Receiver will ignore the usual interpretation of Type 0 messages (as do not use) and continue.			

Abbreviated ASCII Example 1:

WAASCORRECTION ENABLE 0 WAATESTMODE

Abbreviated ASCII Example 2:

WAASCORRECTION ENABLE 120 EGNOSTESTMODE

2.6.69 WAASECUTOFF Set SBAS satellite elevation cut-off

This command sets the elevation cut-off angle for SBAS satellites. The receiver will not start automatically searching for an SBAS satellite until it rises above the cut-off angle. Tracked SBAS satellites that fall below the WAASECUTOFF angle will no longer be tracked unless they are manually assigned (see the ASSIGN command).

This command permits a negative cut-off angle; it could be used in these situations:

- The antenna is at a high altitude, and thus can look below the local horizon
- Satellites are visible below the horizon due to atmospheric refraction

Abbreviated ASCII Syntax:

Message ID: 505

WAASECUTOFF angle

Field	Field Type	ASCII Value	Binary Value	Description	Binary Format	Binary Bytes	Binary Offset
1	header	-	-	This field contains the command name or the message header depending on whether the command is abbreviated ASCII, ASCII or binary, respectively.	-	H	0
2	angle	±90.0 degrees		Elevation cut-off angle relative to horizon.	Float	4	H

ASCII Example:

```
WAASECUTOFF 10.0
```

-
- This command does not affect the tracking of GPS satellites. Similarly, the ECUTOFF command does not affect SBAS satellites.
-

3.1 Log Types

Refer to the LOG command, *see Page 90*, for details on requesting logs.

The receiver is capable of generating many different logs. These logs are divided into the following three types: Synchronous, asynchronous, and polled. The data for synchronous logs is generated on a regular schedule. Asynchronous data is generated at irregular intervals. If asynchronous logs were collected on a regular schedule, they would not output the most current data as soon as it was available. The data in polled logs is generated on demand. An example would be RXCONFIG. It would be polled because it changes only when commanded to do so. Therefore, it would not make sense to log this kind of data ONCHANGED, or ONNEW.

See *Section 1.4, Message Time Stamps on Page 23* for information on how the message time stamp is set for each type of log.

The following table outlines the log types and the valid triggers to use:

Table 41: Log Type Triggers

Type	Recommended Trigger	Illegal Trigger
Synch	ONTIME	ONNEW, ONCHANGED
Asynch	ONCHANGED	-
Polled	ONTIME ^a or ONCE	ONNEW, ONCHANGED

a. Polled log types do not allow fractional offsets and cannot do ontime rates faster than 1Hz.

-
- ☒ 1. The OEM4 family of receivers can handle 30 logs at a time. If you attempt to log more than 30 logs at a time, the receiver will respond with an Insufficient Resources error.
 - 2. The following logs do not support the ONNEXT trigger: GPSEPHEN, RAWEPHEM, RAWGPSSUBFRAME, RAWWAASFRAME, RXSTATUSEVENT and WAAS9.
 - 3. Asynchronous logs, such as MATCHEDPOS, should only be logged ONCHANGED. Otherwise, the most current data is not output when it is available. This is especially true of the ONTIME trigger, which may cause inaccurate time tags to result.
 - 4. Use the ONNEW trigger with the MARKTIME or MARKPOS logs.
-

3.2 Logs By Function

Table 42 lists the logs by function while *Table 43, OEM4 Family Logs in Alphabetical Order on Page 146* is an alphabetical listing of logs (repeated in *Table 44 on Page 151* with the logs in the order of their message IDs).

Table 42: Logs By Function Table

GENERAL RECEIVER CONTROL AND STATUS		
Logs	Descriptions	Type
COMCONFIG	Current COM port configuration	Polled
LOGLIST	List of system logs	Polled
PASSCOM1, PASSXCOM1, PASSAUX, PASSUSB1	Pass-through log, also PASSCOM2, PASSCOM3, PASSXCOM2, PASSUSB2 and PASSUSB3	Asynch
PORTSTATS	COM and, if applicable, USB port statistics	Polled
RXCONFIG	Receiver configuration status	Polled
RXHWLEVELS	Receiver hardware levels	Polled
RXSTATUS	Self-test status	Asynch
RXSTATUSEVENT	Status event indicator	Asynch
VALIDMODELS	Model and expiry date information for receiver	Asynch
VERSION	Receiver hardware and software version numbers	Polled
POSITION, PARAMETERS, AND SOLUTION FILTERING CONTROL		
Logs	Descriptions	Type
AVEPOS	Position averaging log	Asynch
BESTPOS ^a	Best position data	Synch
BESTUTM	Best available UTM data	Synch
BESTXYZ	Cartesian coordinates position data	Synch
BSLNXYZ	RTK XYZ baseline	Synch
GPGGA	NMEA, fix and position data	Synch
GPGLL	NMEA, position data	Synch
GPGRS	NMEA, range residuals	Synch
GPGSA	NMEA, DOP information	Synch
GPGST	NMEA, measurement noise statistics	Synch
IONUTC	Ionospheric and UTC model information	Asynch
MATCHEDPOS ^a	Computed position	Asynch
MATCHEDXYZ	Cartesian coordinates computed position data	Asynch
MARKPOS, MARK2POS	Position at time of mark input event	Asynch
MARKTIME, MARK2TIME	Time of mark input event	Asynch
OMNIHPPPOS	OmniSTAR HP position data	Synch

Continued on Page 141

POSITION, PARAMETERS, AND SOLUTION FILTERING CONTROL		
Logs	Descriptions	Type
PSRDOP	DOP of SVs currently tracking	Asynch
RTKPOS ^a	RTK low latency position	Synch
RTKXYZ	RTK cartesian coordinate position	Synch

- a. The RTK system in the receiver provides two kinds of position solutions. The Matched RTK position is computed with buffered observations, so there is no error due to the extrapolation of base station measurements. This provides the highest accuracy solution possible at the expense of some latency which is affected primarily by the speed of the differential data link. The MATCHEDPOS log contains the matched RTK solution and can be generated for each processed set of base station observations. The RTKDATA log provides additional information about the matched RTK solution.

The Low-Latency RTK position is computed from the latest local observations and extrapolated base station observations. This supplies a valid RTK position with the lowest latency possible at the expense of some accuracy. The degradation in accuracy is reflected in the standard deviation and is summarized in the *GPS Overview* section of the *GPS+ Reference Manual* available on our website at <http://www.novatel.com/support/docupdates.htm>. The amount of time that the base station observations are extrapolated is provided in the "differential age" field of the position log. The Low-Latency RTK system will extrapolate for 60 seconds. The RTKPOS log contains the Low-Latency RTK position when valid, and an "invalid" status when a low-latency RTK solution could not be computed. The BESTPOS log contains the low-latency RTK position when it is valid, and superior to the pseudorange-based position. Otherwise, it will contain the pseudorange-based position.

Continued on Page 142

WAYPOINT NAVIGATION		
Logs	Descriptions	Type
BESTPOS	Best position data	Synch

WAYPOINT NAVIGATION		
Logs	Descriptions	Type
BESTVEL ^a	Velocity data	Synch
GPRMB	NMEA, waypoint status	Synch
GPRMC	NMEA, navigation information	Synch
GPVTG	NMEA, track made good and speed	Synch
NAVIGATE	Navigation waypoint status	Synch
OMNIHPPOS	OmniSTAR HP position data	Synch
PSRPOS	Pseudorange position	Synch
PSRVEL ^a	Pseudorange velocity	Synch
PSRXYZ	Pseudorange cartesian coordinate position	Synch
RTKVEL ^a	RTK Velocity	Synch

- a. The RTK velocity is computed from the latest local observations and extrapolated base station observations. This supplies a valid RTK velocity with the lowest latency possible at the expense of some accuracy. The degradation in accuracy is reflected in the standard deviation and is summarized in the *GPS Overview* section of the *GPS+ Reference Manual* available on our website at www.novatel.com. The amount of time that the base station observations are extrapolated is provided in the "differential age" field of the velocity log. The Low-Latency RTK system will extrapolate for 60 seconds. The RTKVEL log contains the Low-Latency RTK velocity when valid, and an "invalid" status when a low-latency RTK solution could not be computed. The standard deviation fields in the BESTPOS and RTKPOS logs are compared. The BESTVEL log contains the low-latency RTK velocity when it is valid, and as long as the RTK standard deviations are better. Otherwise it contains the pseudorange-based position.

In the PSRVEL log the actual speed and direction of the receiver antenna over ground is provided. The receiver does not determine the direction a vessel, craft, or vehicle is pointed (heading), but rather the direction of motion of the GPS antenna relative to ground.

Continued on Page 143

CLOCK INFORMATION, STATUS, AND TIME		
Logs	Descriptions	Type
CLOCKMODEL	Range bias information	Synch
CLOCKSTEERING	Clock steering status	Asynch
GPZDA	NMEA, UTC time and date	Synch
TIME	Receiver time information	Synch
TIMESYNC	Synchronize time between receivers	Synch
DIFFERENTIAL BASE STATION		
Logs	Descriptions	Type
ALMANAC	Current almanac information	Asynch
RANGE	Satellite range information	Synch
LBANDINFO	L-Band configuration information	Synch
LBANDSTAT	L-Band status information	Synch
RAWLBANDFRAME	Raw L-Band frame data	Asynch
RAWLBANDPACKET	Raw L-Band data packet	Asynch
BESTPOS	Best position data	Synch
BESTVEL	Velocity data	Synch
GPGGA	NMEA, position fix data	Synch
MATCHEDPOS	Computed Position – Time Matched	Asynch
OMNIHPPOS	OmniSTAR HP position data	Synch
REFSTATION	Base station position and health	Asynch
RTKDATA	RTK related data such as baselines and satellite counts	Asynch
PSRPOS	Pseudorange position	Synch
PSRVEL	Pseudorange velocity	Synch
RTKPOS	RTK low latency position	Synch

Continued on Page 144

POST PROCESSING DATA		
Logs	Descriptions	Type
GPSEPHEM	Decoded GPS ephemeris information	Asynch
IONUTC	Ionospheric and UTC model information	Asynch
RAWEPHEM	Raw ephemeris	Asynch
RANGE	Satellite range information	Synch
RANGEGPSL1	L1 version of the RANGE log	Synch
RTKDATA	RTK related data such as baselines and satellite counts.	Asynch
TIME	Receiver clock offset information	Synch
SATELLITE TRACKING AND CHANNEL CONTROL		
Logs	Descriptions	Type
ALMANAC	Current decoded almanac data	Asynch
GPALM	NMEA, almanac data	Synch
GPGSA	NMEA, SV DOP information	Synch
GPGSV	NMEA, satellite-in-view information	Synch
GPSEPHEM	Decoded GPS ephemeris information	Asynch
PSRDOP	DOP of SVs currently tracking	Asynch
RANGE	Satellite range information	Synch
RANGE	L1 version of the RANGE log	Synch
RAWALM	Raw almanac	Asynch
RAWEPHEM	Raw ephemeris	Asynch
RAWGPSSUBFRAME	Raw subframe data	Asynch
RAWGPSWORD	Raw navigation word	Asynch
RAWWAASFRAME	Raw SBAS frame data	Asynch
SATVIS	Satellite visibility	Synch
SATXYZ	SV position in ECEF Cartesian coordinates	Synch
TRACKSTAT	Satellite tracking status	Synch
WAAS0	Remove PRN from the solution	Asynch
WAAS1	PRN mask assignments	Asynch
WAAS2	Fast correction slots 0-12	Asynch
WAAS3	Fast correction slots 13-25	Asynch
WAAS4	Fast correction slots 26-38	Asynch
WAAS5	Fast correction slots 39-50	Asynch
WAAS6	Integrity message	Asynch

Continued on Page 145

WAAS7	Fast correction degradation	Asynch
WAAS9	GEO navigation message	Asynch
WAAS10	Degradation factor	Asynch
WAAS12	SBAS network time and UTC	Asynch
WAAS17	GEO almanac message	Asynch
WAAS18	IGP mask	Asynch
WAAS24	Mixed fast/slow corrections	Asynch
WAAS25	Long-term slow satellite corrections	Asynch
WAAS26	Ionospheric delay corrections	Asynch
WAAS27	SBAS service message	Asynch
WAAS32	CDGPS fast correction slots 0-10	Asynch
WAAS33	CDGPS fast correction slots 11-21	Asynch
WAAS34	CDGPS fast correction slots 22-32	Asynch
WAAS35	CDGPS fast correction slots 39-50	Asynch
WAAS45	CDGPS slow corrections	Asynch
WAASCORR	SBAS range corrections used	Synch

Table 43: OEM4 Family Logs in Alphabetical Order

NovAtel Format Logs		
Datatype	Message ID	Description
ALMANAC	73	Current almanac information
AVEPOS	172	Position averaging
BESTPOS	42	Best position data
BESTUTM	726	Best available UTM data
BESTVEL	99	Velocity data
BESTXYZ	241	Cartesian coordinate position data
BSLNXYZ	686	RTK XYZ baseline
CLOCKMODEL	16	Current clock model matrices
CLOCKSTEERING	26	Clock steering status
CMRDATADESC	389	Base station description information
CMRDATAOBS	390	Base station satellite observation information
CMRDATAREF	391	Base station position information
CMRPLUS	717	CMR+ output message
COMCONFIG	317	Current COM port configuration
GPSEPHM	7	GPS ephemeris data
IONUTC	8	Ionospheric and UTC model information
LOGLIST	5	A list of system logs
MARKPOS, MARK2POS	181, 615	Position at time of mark input event
MARKTIME, MARK2TIME	231, 616	Time of mark input event
MATCHEDPOS	96	RTK Computed Position – Time Matched
MATCHEDXYZ	242	RTK Time Matched cartesian coordinate position data
NAVIGATE	161	Navigation waypoint status
OMNIHPPOS	495	OmniSTAR HP position data
LBANDINFO	730	L-Band configuration information
LBANDSTAT	731	L-Band status information
PASSCOM1, PASSCOM2, PASSCOM3, PASSXCOM1, PASSXCOM2, PASSAUX, PASSUSB1, PASSUSB2, PASSUSB3	233, 234, 235, 405, 406, 690, 607, 608, 609	Pass-through logs
PORTSTATS	72	COM or USB port statistics
PSRDOP	174	DOP of SVs currently tracking
PSRPOS	47	Pseudorange position information
PSRVEL	100	Pseudorange velocity information
PSRXYZ	243	Pseudorange cartesian coordinate position information

Continued on Page 147

NovAtel Format Logs		
Datatype	Message ID	Description
RANGE	43	Satellite range information
RANGECMP	140	Compressed version of the RANGE log
RANGEGPSL1	631	L1 version of the RANGE log
RAWALM	74	Raw almanac
RAWEPHEM	41	Raw ephemeris
RAWGPSSUBFRAME	25	Raw subframe data
RAWGPSWORD	407	Raw navigation word
RAWLBANDFRAME	732	Raw L-Band frame data
RAWLBANDPACKET	733	Raw L-Band data packet
RAWWAASFRAME	287	Raw SBAS frame data
REFSTATION	175	Base station position and health
RTCADATA1	392	Type 1 Differential GPS Corrections
RTCADATAEPHEM	393	Type 7 Ephemeris and Time Information
RTCADATAOBS	394	Type 7 Base Station Observations
RTCADATAREF	395	Type 7 Base Station Parameters
RTCMDATA1	396	Type 1 Differential GPS Corrections
RTCMDATA3	402	Type 3 Base Station Parameters
RTCMDATA9	404	Type 9 Partial Differential GPS Corrections
RTCMDATA15	397	Type 15 Ionospheric Corrections
RTCMDATA16	398	Type 16 Special Message
RTCMDATA1819	399	Type 18 and Type 19 Raw Measurements
RTCMDATA2021	400	Type 20 and Type 21 Measurement Corrections
RTCMDATA22	401	Type 22 Extended Base Station Parameters
RTCMDATA59	403	Type 59N-0 NovAtel Proprietary: RT20 Differential
RTCMDATA1001	784	L1-Only GPS RTK Observables
RTCMDATA1002	785	Extended L1-Only GPS RTK Observables
RTCMDATA1003	786	L1/L2 GPS RTK Observables
RTCMDATA1004	787	Extended L1/L2 GPS RTK Observables
RTCMDATA1005	788	RTK Base Station ARP
RTCMDATA1006	789	RTK Base Station ARP with Antenna Height
RTKDATA	215	RTK specific information
RTKPOS	141	RTK low latency position data
RTKVEL	216	RTK velocity
RTKXYZ	244	RTK cartesian coordinate position data
RXCONFIG	128	Receiver configuration status

Continued on Page 148

NovAtel Format Logs		
Datatype	Message ID	Description
RXHWLEVELS	195	Receiver hardware levels
RXSTATUS	93	Self-test status
RXSTATUSEVENT	94	Status event indicator
SATVIS	48	Satellite visibility
SATXYZ	270	SV position in ECEF Cartesian coordinates
TIME	101	Receiver time information
TIMESYNC	492	Synchronize time between receivers
TRACKSTAT	83	Satellite tracking status
VALIDMODELS	206	Model and expiry date information for receiver
VERSION	37	Receiver hardware and software version numbers
WAAS0	290	Remove PRN from the solution
WAAS1	291	PRN mask assignments
WAAS2	296	Fast correction slots 0-12
WAAS3	301	Fast correction slots 13-25
WAAS4	302	Fast correction slots 26-38
WAAS5	303	Fast correction slots 39-50
WAAS6	304	Integrity message
WAAS7	305	Fast correction degradation
WAAS9	306	GEO navigation message
WAAS10	292	Degradation factor
WAAS12	293	SBAS network time and UTC
WAAS17	294	GEO almanac message
WAAS18	295	IGP mask
WAAS24	297	Mixed fast/slow corrections
WAAS25	298	Long term slow satellite corrections
WAAS26	299	Ionospheric delay corrections
WAAS27	300	SBAS service message
WAAS32	696	CDGPS fast correction slots 0-10
WAAS33	697	CDGPS fast correction slots 11-21
WAAS34	698	CDGPS fast correction slots 22-32
WAAS35	699	CDGPS fast correction slots 39-50
WAAS45	700	CDGPS slow corrections
WAASCORR	313	SBAS range corrections used

Continued on Page 149

NovAtel Format Logs		
Datatype	Message ID	Description
CMR Format Logs ^a		
CMRDESC	310	Base station description information
CMROBS	103	Base station satellite observation information
CMRREF	105	Base station position information
CMRPLUS	717	CMR+ output message
RTCA Format Logs ^a		
RTCA1	10	Type 1 Differential GPS Corrections
RTCAEPHEM	347	Type 7 Ephemeris and Time Information
RTCAOBS	6	Type 7 Base Station Observations
RTCAREF	11	Type 7 Base Station Parameters
RTCM Format Logs ^a		
RTCM1	107	Type 1 Differential GPS Corrections
RTCM3	117	Type 3 Base Station Parameters
RTCM9	275	Type 9 Partial Differential GPS Corrections
RTCM15	307	Type 15 Ionospheric Corrections
RTCM16	129	Type16 Special Message
RTCM16T	131	Type16T Special Text Message
RTCM1819	260	Type18 and Type 19 Raw Measurements
RTCM2021	374	Type 20 and Type 21 Measurement Corrections
RTCM22	118	Type 22 Extended Base Station Parameters
RTCM59	116	Type 59N-0 NovAtel Proprietary: RT20 Differential
RTCMV3 Format Logs ^a		
RTCM1001	772	L1-Only GPS RTK Observables
RTCM1002	774	Extended L1-Only GPS RTK Observables
RTCM1003	776	L1/L2 GPS RTK Observables
RTCM1004	770	Extended L1/L2 GPS RTK Observables
RTCM1005	765	RTK Base Station ARP
RTCM1006	768	RTK Base Station ARP with Antenna Height
NMEA Format Logs		
GPALM	217	Almanac Data
GPGGA	218	GPS Fix Data and Undulation
GPGGALONG	521	GPS Fix Data, Extra Precision and Undulation
GPGGARTK	259	GPS Fix Data with Extra Precision

Continued on Page 150

NMEA Format Logs		
GPGLL	219	Geographic Position - latitude/longitude
GPGRS	220	GPS Range Residuals for Each Satellite
GPGSA	221	GPS DOP and Active Satellites
GPGST	222	Pseudorange Measurement Noise Statistics
GPGSV	223	GPS Satellites in View
GPRMB	224	Generic Navigation Information
GPRMC	225	GPS Specific Information
GPVTG	226	Track Made Good and Ground Speed
GPZDA	227	UTC Time and Date

- a. CMR, RTCA, and RTCM logs may be logged with an A or B extension to give an ASCII or Binary output with a NovAtel header followed by Hex or Binary data respectively

Table 44: OEM4 Family Logs in Order of their Message IDs

NovAtel Format Logs		
Message ID	Datatype	Description
5	LOGLIST	A list of system logs
7	GPSEPHEM	GPS ephemeris data
8	IONUTC	Ionospheric and UTC model information
16	CLOCKMODEL	Current clock model matrices
25	RAWGPSSUBFRAME	Raw subframe data
26	CLOCKSTEERING	Clock steering status
37	VERSION	Receiver hardware and software version numbers
41	RAWEPHEM	Raw ephemeris
42	BESTPOS	Best position data
43	RANGE	Satellite range information
47	PSRPOS	Pseudorange position information
48	SATVIS	Satellite visibility
72	PORTSTATS	COM or USB port statistics
73	ALMANAC	Current almanac information
74	RAWALM	Raw almanac
83	TRACKSTAT	Satellite tracking status
93	RXSTATUS	Self-test status
94	RXSTATUSEVENT	Status event indicator
96	MATCHEDPOS	RTK Computed Position – Time Matched
99	BESTVEL	Velocity data
100	PSRVEL	Pseudorange velocity information
101	TIME	Receiver time information
128	RXCONFIG	Receiver configuration status
140	RANGECMP	Compressed version of the RANGE log
141	RTKPOS	RTK low latency position data
161	NAVIGATE	Navigation waypoint status
172	AVEPOS	Position averaging
174	PSRDOP	DOP of SVs currently tracking
175	REFSTATION	Base station position and health
181	MARKPOS	Position at time of mark input event
195	RXHWLEVELS	Receiver hardware levels
206	VALIDMODELS	Model and expiry date information for receiver

Continued on Page 152

NovAtel Format Logs		
Message ID	Datatype	Description
215	RTKDATA	RTK specific information
216	RTKVEL	RTK velocity
231	MARKTIME	Time of mark input event
233, 234, 235	PASSCOM1, PASSCOM2, PASSCOM3	Pass-through logs
241	BESTXYZ	Cartesian coordinate position data
242	MATCHEDXYZ	RTK Time Matched cartesian coordinate position data
243	PSRXYZ	Pseudorange cartesian coordinate position information
244	RTKXYZ	RTK cartesian coordinate position data
270	SATXYZ	SV position in ECEF Cartesian coordinates
287	RAWWAASFRAME	Raw SBAS frame data
290	WAAS0	Remove PRN from the solution
291	WAAS1	PRN mask assignments
292	WAAS10	Degradation factor
293	WAAS12	SBAS network time and UTC
294	WAAS17	GEO almanac message
295	WAAS18	IGP mask
296	WAAS2	Fast correction slots 0-12
297	WAAS24	Mixed fast/slow corrections
298	WAAS25	Long term slow satellite corrections
299	WAAS26	Ionospheric delay corrections
300	WAAS27	SBAS service message
301	WAAS3	Fast correction slots 13-25
302	WAAS4	Fast correction slots 26-38
303	WAAS5	Fast correction slots 39-50
304	WAAS6	Integrity message
305	WAAS7	Fast correction degradation
306	WAAS9	GEO navigation message
313	WAASCORR	SBAS range corrections used
317	COMCONFIG	Current COM port configuration
389	CMRDATADESC	Base station description information
390	CMRDATAOBS	Base station satellite observation information
391	CMRDATAREF	Base station position information

Continued on Page 153

NovAtel Format Logs		
Message ID	Datatype	Description
392	RTCADATA1	Type 1 Differential GPS Corrections
393	RTCADATAEPHEM	Type 7 Ephemeris and Time Information
394	RTCADATAOBS	Type 7 Base Station Observations
395	RTCADATAREF	Type 7 Base Station Parameters
396	RTCMDATA1	Type 1 Differential GPS Corrections
397	RTCMDATA15	Type 15 Ionospheric Corrections
398	RTCMDATA16	Type 16 Special Message
399	RTCMDATA1819	Type 18 and Type 19 Raw Measurements
400	RTCMDATA2021	Type 20 and Type 21 Measurement Corrections
401	RTCMDATA22	Type 22 Extended Base Station Parameters
402	RTCMDATA3	Type 3 Base Station Parameters
403	RTCMDATA59	Type 59N-0 NovAtel Proprietary: RT20 Differential
404	RTCMDATA9	Type 9 Partial Differential GPS Corrections
405, 406	PASSXCOM1, PASSXCOM2	Pass-through logs
407	RAWGPSWORD	Raw navigation word
732	RAWLBANDFRAME	Raw L-Band frame data
733	RAWLBANDPACKET	Raw L-Band data packet
492	TIMESYNC	Synchronize time between receivers
495	OMNIHPPPOS	OmniSTAR HP position data
730	LBANDINFO	L-Band configuration information
731	LBANDSTAT	L-Band status information
607, 608, 609	PASSUSB1, PASSUSB2, PASSUSB3	Pass-through logs (for receivers that support USB)
615	MARK2POS	Time of mark input event
616	MARK2TIME	Position at time of mark input event
631	RANGEGPSL1	L1 version of the RANGE log
686	BSLNXYZ	RTK XYZ baseline
690	PASSAUX	Pass-through log for AUX port
696	WAAS32	CDGPS fast correction slots 0-10
697	WAAS33	CDGPS fast correction slots 11-21
698	WAAS34	CDGPS fast correction slots 22-32

Continued on Page 154

699	WAAS35	CDGPS fast correction slots 39-50
700	WAAS45	CDGPS slow corrections
717	CMRPLUS	CMR+ output message
726	BESTUTM	Best available UTM data
784	RTCMDATA1001	L1-Only GPS RTK Observables
785	RTCMDATA1002	Extended L1-Only GPS RTK Observables
786	RTCMDATA1003	L1/L2 GPS RTK Observables
787	RTCMDATA1004	Extended L1/L2 GPS RTK Observables
788	RTCMDATA1005	RTK Base Station ARP
789	RTCMDATA1006	RTK Base Station ARP with Antenna Height
CMR Format Logs ^a		
103	CMROBS	Base station satellite observation information
105	CMRREF	Base station position information
310	CMRDESC	Base station description information
717	CMRPLUS	CMR+ output message
RTCA Format Logs ^a		
6	RTCAOBS	Type 7 Base Station Observations
10	RTCA1	Type 1 Differential GPS Corrections
11	RTCAREF	Type 7 Base Station Parameters
347	RTCAEPHEM	Type 7 Ephemeris and Time Information
RTCM Format Logs ^a		
107	RTCM1	Type 1 Differential GPS Corrections
116	RTCM59	Type 59N-0 NovAtel Proprietary: RT20 Differential
117	RTCM3	Type 3 Base Station Parameters
118	RTCM22	Type 22 Extended Base Station Parameters
129	RTCM16	Type16 Special Message
131	RTCM16T	Type16T Special Text Message
260	RTCM1819	Type18 and Type 19 Raw Measurements
275	RTCM9	Type 9 Partial Differential GPS Corrections
307	RTCM15	Type 15 Ionospheric Corrections
374	RTCM2021	Type 20 and Type 21 Measurement Corrections

Continued on Page 155

RTCMV3 Format Logs ^a		
765	RTCM1005	RTK Base Station ARP
768	RTCM1006	RTK Base Station ARP with Antenna Height
770	RTCM1004	Extended L1/L2 GPS RTK Observables
772	RTCM1001	L1-Only GPS RTK Observables
774	RTCM1002	Extended L1-Only GPS RTK Observables
776	RTCM1003	L1/L2 GPS RTK Observables
NMEA Format Data Logs		
217	GPALM	Almanac Data
218	GPGGA	GPS Fix Data and Undulation
219	GPGLL	Geographic Position - latitude/longitude
220	GPRGS	GPS Range Residuals for Each Satellite
221	GPGSA	GPS DOP and Active Satellites
222	GPGST	Pseudorange Measurement Noise Statistics
223	GPGSV	GPS Satellites in View
224	GPRMB	Generic Navigation Information
225	GPRMC	GPS Specific Information
226	GPVTG	Track Made Good and Ground Speed
227	GPZDA	UTC Time and Date
259	GPGGARTK	GPS Fix Data with Extra Precision
521	GPGGALONG	GPS Fix Data, Extra Precision and Undulation

- a. CMR, RTCA, RTCM and RTCMV3 logs may be logged with an A or B extension to give an ASCII or Binary output with a NovAtel header followed by Hex or Binary data respectively

3.3 MiLLennium GPSCard Compatibility

Table 45, *MiLLennium OEM3 Log Comparison* on Page 156 shows the MiLLennium logs that are comparable to current OEM4 family logs.

Table 45: MiLLennium OEM3 Log Comparison

MiLLennium Log	Comparable OEM4 Family Log
ALM	ALMANAC and IONUTC
BSL	RTKDATA
CDS	PORTSTATS
CLK	CLOCKMODEL
CLM	CLOCKMODEL
CMR	CMR
COM1	PASSCOM1
COM2	PASSCOM2
DOP	PSRDOP
ETS	TRACKSTAT
FRM	RAWGPSSUBFRAME and RAWWAASFRAME
FRW	RAWGPSWORD
GGB	Not currently supported.
GP* (NMEA logs)	Same as MiLLennium.
MKP	MARKPOS
MKT	MARKTIME
NAV	NAVIGATE
PAV	AVEPOS
POS	BESTPOS
PRTK	BESTPOS and RTKPOS
PVA	BESTXYZ, MATCHEDXYZ, PSRXYZ and RTKXYZ
PXY	BESTXYZ, MATCHEDXYZ, PSRXYZ and RTKXYZ
RAL	RAWALM
RAS	RAWALM
RBT	Not currently supported.
RCCA	RXCONFIG, COMCONFIG and LOGLIST
RCS	RXSTATUS and VERSION
REP	RAWEPHEM
RGE	RANGE and RANGECMP
RPS	REFSTATION
RTCA	RTCA
RTK	MATCHEDPOS
RTKO	RTKDATA
RTCM	RTCM
RVS	RXSTATUS
SAT	SATVIS
SBT	Not currently supported.
SPH	PSRVEL
SVD	SATXYZ
TM1	TIME
VER	VERSION
VLH	PSRVEL
WAL	Not currently supported.
WRC	Not currently supported.

3.4 Log Reference

3.4.1 ALMANAC Decoded Almanac

This log contains the decoded almanac parameters from Subframe four and five as received from the satellite with the parity information removed and appropriate scaling applied. Multiple messages are transmitted, one for each SV almanac collected. For more information on Almanac data, refer to the GPS SPS Signal Specification. (See the appendix on *Standards and References* in the *GPS+ Reference Manual*.)

The OEM4 family of receivers automatically save almanacs in their non-volatile memory (NVM), therefore creating an almanac boot file is not necessary.

Message ID: 73 **Log Type:** Asynch

Field #	Field type	Data Description	Format	Binary Bytes	Binary Offset
1	header	Log header		H	0
2	#messages	The number of satellite PRN almanac messages to follow. Set to zero until almanac data is available.	Long	4	H
3	PRN	Satellite PRN number for current message, dimensionless	Ulong	4	H+4
4	week	Almanac reference week (GPS week number)	Ulong	4	H+8
5	seconds	Almanac reference time, seconds into the week	Double	8	H+12
6	ecc	Eccentricity, dimensionless - defined for a conic section where $e=0$ is a circle, $e=1$ is an ellipse, $0<e<1$ is a parabola and $e>1$ is a hyperbola.	Double	8	H+20
7	$\dot{\omega}$	Rate of right ascension, radians/second	Double	8	H+28
8	ω_0	Right ascension, radians	Double	8	H+36
9	ω	Argument of perigee, radians - measurement along the orbital path from the ascending node to the point where the SV is closest to the Earth, in the direction of the SV's motion.	Double	8	H+44
10	M_0	Mean anomaly of reference time, radians	Double	8	H+52
11	a_{f0}	Clock aging parameter, seconds	Double	8	H+60
12	a_{f1}	Clock aging parameter, seconds/second	Double	8	H+68
13	N	Corrected mean motion, radians/second	Double	8	H+76
14	A	Semi-major axis, meters	Double	8	H+84
15	incl-angle	Angle of inclination relative to 0.3π , radians	Double	8	H+92
16	SV config	Satellite configuration	Ulong	4	H+100
17	health-prn	SV health from Page 25 of subframe 4 or 5 (6 bits)	Ulong	4	H+104
18	health-alm	SV health from almanac (8 bits)	Ulong	4	H+108
19	antispoof	Anti-spoofing on: 0 = FALSE 1 = TRUE	Enum	4	H+112
20...	Next PRN offset = $H + 4 + (\#messages \times 112)$				
21	xxxx	32-bit CRC (ASCII and Binary only)	Hex	4	$H + 4 + (112 \times \#messages)$
22	[CR][LF]	Sentence terminator (ASCII only)	-	-	-

Recommended Input:

log almanaca onchanged

ASCII Example:

```
#ALMANACA, COM1, 0, 74.5, SATTIME, 1263, 236634.000, 00000000, 06de, 1522;  
28,  
1, 1263, 405504.0, 5.355835e-03, -7.61174563e-09, -2.1391179e+00, -1.6730555e+00,  
2.3245471e+00, 3.36647034e-04, 0.00000000, 1.45865455e-04, 2.6558955e+07,  
3.58388246e-02, 1, 0, 0, TRUE,  
2, 1263, 405504.0, 2.360344e-02, -8.06890753e-09, -1.66624169e-01, -1.6950735e+00,  
1.1302154e+00, -2.98500061e-04, -7.27595761e-12, 1.45862594e-04, 2.6559302e+07,  
-9.67726161e-03, 1, 63, 255, FALSE,  
...  
17, 1263, 405504.0, 1.641607e-02, -8.06890753e-09, 2.1420401e+00, -2.8048764e+00,  
2.9039840e+00, 2.48908997e-04, 1.81898940e-11, 1.45865164e-04, 2.6558990e+07,  
2.69225612e-02, 1, 0, 0, TRUE,  
...  
31, 1263, 405504.0, 1.216650e-02, -7.97747515e-09, 9.27414599e-01, 9.76235710e-01,  
-3.0757944e+00, 5.34057617e-05, 2.91038305e-11, 1.45855131e-04, 2.6560208e+07,  
-5.17119305e-03, 1, 0, 0, FALSE*e47590e8
```

3.4.2 AVEPOS Position Averaging

When position averaging is underway, the various fields in the AVEPOS log contain the parameters being used in the position averaging process.

See the description of the POSAVE command on *Page 101*. Refer also to the *Height Relationships and Pseudorange Algorithms* sections of the *GPS+ Reference Manual* available on our website at <http://www.novatel.com/support/docupdates.htm>.

-
- ☒ 1. All quantities are referenced to the geoid (average height above sea level), regardless of the use of the DATUM or USERDATUM commands, except for the height parameter (field 6). The relation between the geoid and the WGS84 ellipsoid is the geoidal undulation, and can be obtained from the PSRPOS log.
 - 2. Asynchronous logs should only be logged ONCHANGED. Otherwise, the most current data is not output when it is available. This is especially true of the ONTIME trigger, which may cause inaccurate time tags to result.
-

Message ID: 172

Log Type: Asynch

Field #	Field type	Data Description	Format	Binary Bytes	Binary Offset
1	header	Log header		H	0
2	lat	Average WGS84 latitude (degrees)	Double	8	H
3	lon	Average WGS84 longitude (degrees)	Double	8	H+8
4	ht	Average height above sea level, or geoid (m)	Double	8	H+16
5	lat σ	Estimated average standard deviation of latitude solution element, in meters	Float	4	H+24
6	lon σ	Estimated average standard deviation of longitude solution element, in meters	Float	4	H+28
7	hgt σ	Estimated average standard deviation of height solution element, in meters	Float	4	H+32
8	posave	Position averaging status (see <i>Table 46</i>)	Enum	4	H+36
9	ave time	Elapsed time of averaging (s)	Ulong	4	H+40
10	samples	Number of samples in the average	Ulong	4	H+44
11	xxxx	32-bit CRC (ASCII and Binary only)	Hex	4	H+48
12	[CR][LF]	Sentence terminator (ASCII only)	-	-	-

Recommended Input:

log aveposa onchanged

ASCII Example:

```
#AVEPOSA,COM1,0,72.5,FINESTEERING,1263,326212.000,80100000,e3b4,1516;
51.11638470693,-114.03823265099,1062.648179488,2.0197,1.1808,2.9307,
INPROGRESS,600,2*4c9f53da
```

Table 46: Position Averaging Status

Binary	ASCII	Description
0	OFF	Receiver is not averaging
1	INPROGRESS	Averaging is in progress
2	COMPLETE	Averaging is complete

3.4.3 BESTPOS Best Position

This log contains the best available combined GPS and inertial navigation system (INS - if available) position computed by the receiver. In addition, it reports several status indicators, including differential age, which is useful in predicting anomalous behavior brought about by outages in differential corrections. A differential age of 0 indicates that no differential correction was used.

With the system operating in an RTK mode, this log will reflect the latest low-latency solution for up to 60 seconds after reception of the last base station observations. After this 60 second period, the position reverts to the best solution available; the degradation in accuracy is reflected in the standard deviation fields. If the system is not operating in an RTK mode, pseudorange differential solutions continue for the time specified in the DGPSTIMEOUT command, see *Page 69*.

See also the table footnote for position logs on *Page 141* as well as the MATCHEDPOS, PSRPOS and RTKPOS logs, on *Pages 217, 231 and 291* respectively.

Message ID: 42

Log Type: Synch

Field #	Field type	Data Description	Format	Binary Bytes	Binary Offset
1	header	Log header		H	0
2	sol status	Solution status, see <i>Table 48, Solution Status on Page 163</i>	Enum	4	H
3	pos type	Position type, see <i>Table 47, Position or Velocity Type on Page 162</i>	Enum	4	H+4
4	lat	Latitude	Double	8	H+8
5	lon	Longitude	Double	8	H+16
6	hgt	Height above mean sea level	Double	8	H+24
7	undulation	Undulation - the relationship between the geoid and the ellipsoid (m) of the chosen datum ^a	Float	4	H+32
8	datum id#	Datum ID number (see <i>Chapter 2, Table 20, Datum Transformation Parameters on Page 65</i>)	Enum	4	H+36
9	lat σ	Latitude standard deviation	Float	4	H+40
10	lon σ	Longitude standard deviation	Float	4	H+44
11	hgt σ	Height standard deviation	Float	4	H+48
12	stn id	Base station ID	Char[4]	4	H+52
13	diff_age	Differential age in seconds	Float	4	H+56
14	sol_age	Solution age in seconds	Float	4	H+60
15	#obs	Number of observations tracked	Uchar	1	H+64
16	#GPSL1	Number of GPS L1 ranges used in computation	Uchar	1	H+65
17	#L1	Number of GPS L1 ranges above the RTK mask angle	Uchar	1	H+66
18	#L2	Number of GPS L2 ranges above the RTK mask angle	Uchar	1	H+67
19	Reserved		Uchar	1	H+68
20			Uchar	1	H+69
21			Uchar	1	H+70
22			Uchar	1	H+71
23	xxxx	32-bit CRC (ASCII and Binary only)	Hex	4	H+72
24	[CR][LF]	Sentence terminator (ASCII only)	-	-	-

- a. When using a datum other than WGS84, the undulation value also includes the vertical shift due to differences between the datum in use and WGS84

Recommended Input:

```
log bestposa ontime 1
```

See *Section 2.1, Command Formats on Page 26* for more examples of log requests.

ASCII Example:

```
#BESTPOSA, COM1, 0, 77.0, FINESTEERING, 1263, 238037.000, 00000000, 4ca6, 1522;
SOL_COMPUTED, NARROW_INT, 51.11633810554, -114.03839550586, 1048.2343, 16.2711,
WGS84, 0.0087, 0.0085, 0.0145, "AAAA", 1.000, 0.000, 8, 7, 7, 7, 0, 0, 0, 0*212063e0
```

Table 47: Position or Velocity Type

Type (binary)	Type (ASCII)	Description
0	NONE	No solution
1	FIXEDPOS	Position has been fixed by the FIX POSITION command
2	FIXEDHEIGHT	Position has been fixed by the FIX HEIGHT/AUTO command
3-7	Reserved	
8	DOPPLER_VELOCITY	Velocity computed using instantaneous Doppler
9-15	Reserved	
16	SINGLE	Single point position
17	PSRDIFF	Pseudorange differential solution
18	WAAS	Solution calculated using corrections from an SBAS
19	PROPAGATED	Propagated by a Kalman filter without new observations
20	OMNISTAR	OmniSTAR VBS position (L1 sub-meter) ^a
21-31	Reserved	
32	L1_FLOAT	Floating L1 ambiguity solution
33	IONOFREE_FLOAT	Floating ionospheric-free ambiguity solution
34	NARROW_FLOAT	Floating narrow-lane ambiguity solution
48	L1_INT	Integer L1 ambiguity solution
49	WIDE_INT	Integer wide-lane ambiguity solution
50	NARROW_INT	Integer narrow-lane ambiguity solution
51	RTK_DIRECT_INS	RTK status where the RTK filter is directly initialized from the INS filter ^b
52-56	INS calculated position types ^b	
64	OMNISTAR_HP	OmniSTAR HP position (L1/L2 decimeter) ^a
65	OMNISTAR_XP	OmniSTAR XP position
66	CDGPS	Position solution using CDGPS correction ^a

- a. In addition to a NovAtel receiver with L-Band capability, a subscription to the OmniSTAR, or use of the free CDGPS, service is required. Contact NovAtel for details.
- b. Output only by the BESTPOS and BESTVEL logs when using an inertial navigation system such as NovAtel's SPAN products. Please visit our website, refer to your *SPAN User Manual*, or contact NovAtel for more information.

Table 48: Solution Status

Solution Status		Description
(Binary)	(ASCII)	
0	SOL_COMPUTED	Solution computed
1	INSUFFICIENT_OBS	Insufficient observations
2	NO_CONVERGENCE	No convergence
3	SINGULARITY	Singularity at parameters matrix
4	COV_TRACE	Covariance trace exceeds maximum (trace > 1000 m)
5	TEST_DIST	Test distance exceeded (maximum of 3 rejections if distance > 10 km)
6	COLD_START	Not yet converged from cold start
7	V_H_LIMIT	Height or velocity limits exceeded (in accordance with COCOM export licensing restrictions)
8	VARIANCE	Variance exceeds limits
9	RESIDUALS	Residuals are too large
10	DELTA_POS	Delta position is too large
11	NEGATIVE_VAR	Negative variance
12	Reserved	
13	INTEGRITY_WARNING	Large residuals make position unreliable
14-17	INS solution status values ^a	
18	PENDING	When a FIX POSITION command is entered, the receiver computes its own position and determines if the fixed position is valid ^b
19	INVALID_FIX	The fixed position, entered using the FIX POSITION command, is not valid
20	UNAUTHORIZED	Position type is unauthorized - HP or XP on a receiver not authorized for it

- a. Output only when using an inertial navigation system such as NovAtel's SPAN products. Please visit our website, refer to your *SPAN User Manual*, or contact NovAtel for more information.
- b. PENDING implies there are not enough satellites being tracked to verify if the FIX POSITION entered into the receiver is valid. The receiver needs to be tracking two or more GPS satellites to perform this check. Under normal conditions you should only see PENDING for a few seconds on power up before the GPS receiver has locked onto its first few satellites. If your antenna is obstructed (or not plugged in) and you have entered a FIX POSITION command, then you may see PENDING indefinitely.

3.4.4 BESTUTM Best Available UTM Data

This log contains the best available position computed by the receiver in UTM coordinates.

See also the UTMZONE command on *Pages 135* and the BESTPOS log on *Page 161*.

Message ID: 726
Log Type: Synch

Field #	Field type	Data Description	Format	Binary Bytes	Binary Offset
1	header	Log header		H	0
2	sol status	Solution status, see <i>Table 48, Solution Status on Page 163</i>	Enum	4	H
3	pos type	Position type, see <i>Table 47, Position or Velocity Type on Page 162</i>	Enum	4	H+4
4	z#	Longitudinal zone number	Ulong	4	H+8
5	zletter	Latitudinal zone letter	Ulong	4	H+12
6	northing	Northing (m) where the origin is defined as the equator in the northern hemisphere and as a point 10000000 metres south of the equator in the southern hemisphere (that is, a 'false northing' of 10000000 m)	Double	8	H+16
7	easting	Easting (m) where the origin is 500000 m west of the central meridian of each longitudinal zone (that is, a 'false easting' of 500000 m)	Double	8	H+24
8	hgt	Height above mean sea level	Double	8	H+32
9	undulation	Undulation - the relationship between the geoid and the ellipsoid (m) of the chosen datum ^a	Float	4	H+40
10	datum id#	Datum ID number (see <i>Chapter 2, Table 20, Datum Transformation Parameters on Page 65</i>)	Enum	4	H+44
11	N σ	Northing standard deviation	Float	4	H+48
12	E σ	Easting standard deviation	Float	4	H+52
13	hgt σ	Height standard deviation	Float	4	H+56
14	stn id	Base station ID	Char[4]	4	H+60
15	diff_age	Differential age in seconds	Float	4	H+64
16	sol_age	Solution age in seconds	Float	4	H+68
17	#obs	Number of satellites tracked	Uchar	1	H+72
18	#GPSL1	Number of GPS L1 ranges used in computation	Uchar	1	H+73
19	#L1	Number of GPS L1 ranges above the RTK mask angle	Uchar	1	H+74
20	#L2	Number of GPS L2 ranges above the RTK mask angle	Uchar	1	H+75
21	Reserved		Uchar	1	H+76
22			Uchar	1	H+77
23			Uchar	1	H+78
24			Uchar	1	H+79
25	xxxx	32-bit CRC (ASCII and Binary only)	Hex	4	H+80
26	[CR][LF]	Sentence terminator (ASCII only)	-	-	-

- a. When using a datum other than WGS84, the undulation value also includes the vertical shift due to differences between the datum in use and WGS84

-
- ☒ The latitude limits of the UTM System are 80°S to 84°N. If your position is outside this range, the BESTUTM log outputs a northing, easting and height of 0.0, along with a zone letter of '*' and a zone number of 0, so that it is obvious that the data in the log is unusable.
-

Recommended Input:

```
log bestutma ontime 1
```

ASCII Example:

```
#BESTUTMA, COM1, 0, 78.0, FINESTEERING, 1317, 400258.000, 00000000, ef8c, 1855;  
SOL_COMPUTED, NARROW_INT, 11, U, 56666613.8767, 706904.8008, 1059.3900,  
-16.2613, WGS84, 0.0122, 0.0109, 0.0129, "AAAA", 2.000, 0.000, 8, 6, 6, 6,  
0, 0, 0, 0*73db7bac
```

3.4.5 BESTVEL Best Available Velocity Data

This log contains the best available velocity information computed by the receiver. In addition, it reports a velocity status indicator, which is useful in indicating whether or not the corresponding data is valid. The velocity measurements sometimes have a latency associated with them. The time of validity is the time tag in the log minus the latency value. See also the table footnote for velocity logs on *Page 142*.

The velocity is typically computed from the average change in pseudorange over the time interval or the RTK Low Latency filter. As such, it is an average velocity based on the time difference between successive position computations and not an instantaneous velocity at the BESTVEL time tag. The velocity latency to be subtracted from the time tag will normally be 1/2 the time between filter updates. Under default operation, the positioning filters are updated at a rate of 2 Hz. This translates into a velocity latency of 0.25 second. The latency can be reduced by increasing the update rate of the positioning filter being used by requesting the BESTVEL or BESTPOS messages at a rate higher than 2 Hz. For example, a logging rate of 10 Hz would reduce the velocity latency to 0.005 seconds. For integration purposes, the velocity latency should be applied to the record time tag.

While you are standing still, your velocity may jump several centimetres per second. Once you start moving, your velocity will become less noisy. The latency of the instantaneous doppler velocity is always 0.15 seconds. You will know that you have an instantaneous doppler velocity solution when you see DOPPLER_VELOCITY in field #3 (vel type) below. BESTVEL uses an instantaneous doppler velocity that has low latency and is not delta position dependent. If you change your velocity quickly, you can see this in the DOPPLER_VELOCITY solution.

A valid solution with a latency of 0.0 indicates that the instantaneous Doppler measurement was used to calculate velocity.

Message ID: 99

Log Type: Synch

Field #	Field type	Data Description	Format	Binary Bytes	Binary Offset
1	header	Log header		H	0
2	sol status	Solution status, see <i>Table 48, Solution Status on Page 163</i>	Enum	4	H
3	vel type	Velocity type, see <i>Table 47, Position or Velocity Type on Page 162</i>	Enum	4	H+4
4	latency	A measure of the latency in the velocity time tag in seconds. It should be subtracted from the time to give improved results.	Float	4	H+8
5	age	Differential age in seconds	Float	4	H+12
6	hor spd	Horizontal speed over ground, in meters per second	Double	8	H+16
7	trk gnd	Actual direction of motion over ground (track over ground) with respect to True North, in degrees	Double	8	H+24
8	vert spd	Vertical speed, in meters per second, where positive values indicate increasing altitude (up) and negative values indicate decreasing altitude (down)	Double	8	H+32
9	Reserved		Float	4	H+40
10	xxxx	32-bit CRC (ASCII and Binary only)	Hex	4	H+44
11	[CR][LF]	Sentence terminator (ASCII only)	-	-	-

Recommended Input:

log bestvela ontime 1

ASCII Example:

```
#BESTVELA, COM1, 0, 70.0, FINESTEERING, 1263, 238111.000, 00000000, 827b, 1522;  
SOL_COMPUTED, NARROW_INT, 0.250, 1.000, 0.0026, 82.138071, 0.0077, 0.0*0e7a2d7e
```

3.4.6 BESTXYZ Best Available Cartesian Position and Velocity

This log contains the receiver's best available position and velocity in ECEF coordinates. The position and velocity status fields indicate whether or not the corresponding data is valid. See *Figure 8, Page 170* for a definition of the ECEF coordinates.

See also the BESTPOS and BESTVEL logs, on *Pages 161 and 164* respectively.

☒ These quantities are always referenced to the WGS84 ellipsoid, regardless of the use of the DATUM or USERDATUM commands.

Message ID: 241

Log Type: Synch

Field #	Field type	Data Description	Format	Binary Bytes	Binary Offset
1	header	Log header		H	0
2	P-sol status	Solution status, see <i>Table 48, Solution Status on Page 163</i>	Enum	4	H
3	pos type	Position type, see <i>Table 47, Position or Velocity Type on Page 162</i>	Enum	4	H+4
4	P-X	Position X-coordinate (m)	Double	8	H+8
5	P-Y	Position Y-coordinate (m)	Double	8	H+16
6	P-Z	Position Z-coordinate (m)	Double	8	H+24
7	P-X σ	Standard deviation of P-X (m)	Float	4	H+32
8	P-Y σ	Standard deviation of P-Y (m)	Float	4	H+36
9	P-Z σ	Standard deviation of P-Z (m)	Float	4	H+40
10	V-sol status	Solution status, see <i>Table 48, Solution Status on Page 163</i>	Enum	4	H+44
11	vel type	Velocity type, see <i>Table 47, Position or Velocity Type on Page 162</i>	Enum	4	H+48
12	V-X	Velocity vector along X-axis (m/s)	Double	8	H+52
13	V-Y	Velocity vector along Y-axis (m/s)	Double	8	H+60
14	V-Z	Velocity vector along Z-axis (m/s)	Double	8	H+68
15	V-X σ	Standard deviation of V-X (m/s)	Float	4	H+76
16	V-Y σ	Standard deviation of V-Y (m/s)	Float	4	H+80
17	V-Z σ	Standard deviation of V-Z (m/s)	Float	4	H+84
18	stn ID	Base station identification	Char[4]	4	H+88
19	V-latency	A measure of the latency in the velocity time tag in seconds. It should be subtracted from the time to give improved results.	Float	4	H+92
20	diff_age	Differential age in seconds	Float	4	H+96
21	sol_age	Solution age in seconds	Float	4	H+100
22	#obs	Number of observations tracked	Uchar	1	H+104
23	#GPSL1	Number of GPS L1 ranges used in computation	Uchar	1	H+105

Continued on Page 169

Field #	Field type	Data Description	Format	Binary Bytes	Binary Offset
24	#L1	Number of GPS L1 ranges above the RTK mask angle	Uchar	1	H+106
25	#L2	Number of GPS L2 ranges above the RTK mask angle	Uchar	1	H+107
26	Reserved		Char	1	H+108
27			Char	1	H+109
28			Char	1	H+110
29			Char	1	H+111
30	xxxx	32-bit CRC (ASCII and Binary only)	Hex	4	H+112
31	[CR][LF]	Sentence terminator (ASCII only)	-	-	-

Recommended Input:

```
log bestxyza ontime 1
```

ASCII Example:

```
#BESTXYZA, COM1, 0, 78.5, FINESTEERING, 1263, 238168.000, 00000000, f798, 1522;
SOL_COMPUTED, NARROW_INT, -1634532.4439, -3664608.9024, 4942482.7154,
0.0086, 0.0090, 0.0191, SOL_COMPUTED, NARROW_INT, 0.0017, 0.0044, -0.0045,
0.0172, 0.0180, 0.0381, "AAAA", 0.250, 2.000, 0.000, 9, 7, 7, 7, 0, 0, 0, 0*b712e9d0
```

- Definitions - *

- Origin = Earth's center of mass
- Z-Axis = Parallel to the direction of the Conventional Terrestrial Pole (CTP) for polar motion, as defined by the Bureau International de l'Heure (BIH) on the basis of the coordinates adopted for the BIH stations.
- X-Axis = Intersection of the WGS 84 Reference Meridian Plane and the plane of the CTP's Equator, the Reference Meridian being parallel to the Zero Meridian defined by the BIH on the basis of the coordinates adopted for the BIH stations.
- Y-Axis = Completes a right-handed, earth-centered, earth-fixed (ECEF) orthogonal coordinate system, measured in the plane of the CTP Equator, 90° East of the X-Axis.

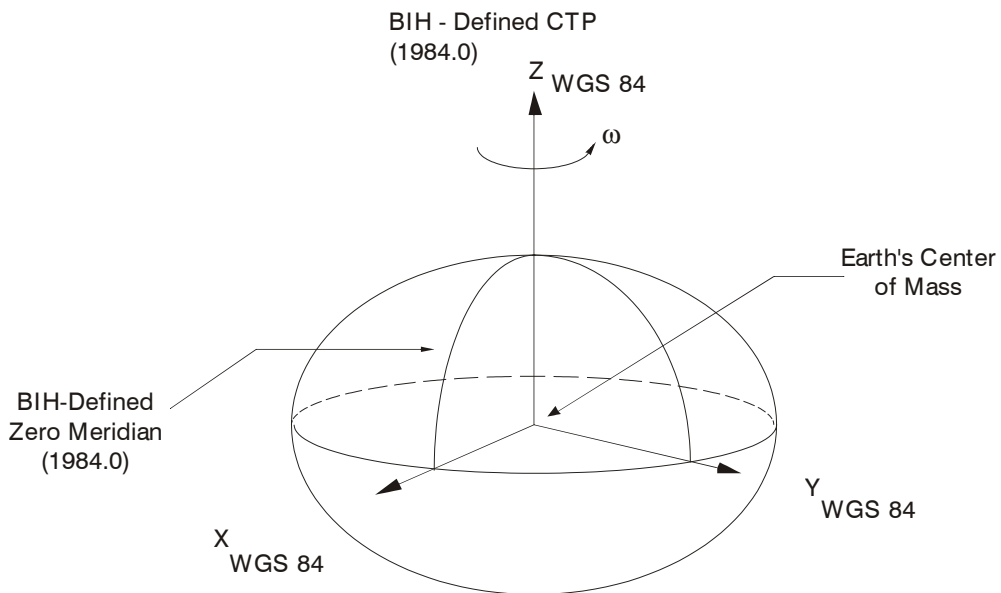

* Analogous to the BIH Defined Conventional Terrestrial System (CTS), or BTS, 1984.0.

Figure 8: The WGS84 ECEF Coordinate System

3.4.7 BSLNXYZ RTK XYZ Baseline RTK

This log contains the receiver's RTK baseline in ECEF coordinates. The status field indicates whether or not the corresponding data is valid. See *Figure 8, Page 170* for a definition of the ECEF coordinates.

The BSLNXYZ log comes from time matched base and rover observations like the MATCHEDXYZ log on *Page 219*.

-
- Asynchronous logs, such as BSLNXYZ, should only be logged ONCHANGED. Otherwise, the most current data is not output when it is available. This is especially true of the ONTIME trigger, which may cause inaccurate time tags to result.
-

Message ID: **686**
Log Type: **Asynch**

Field #	Field type	Data Description	Format	Binary Bytes	Binary Offset
1	header	Log header		H	0
2	sol status	Solution status, see <i>Table 48, Solution Status on Page 163</i>	Enum	4	H
3	bsln type	Baseline type, see <i>Table 47, Position or Velocity Type on Page 162</i>	Enum	4	H+4
4	B-X	Baseline X-coordinate (m)	Double	8	H+8
5	B-Y	Baseline Y-coordinate (m)	Double	8	H+16
6	B-Z	Baseline Z-coordinate (m)	Double	8	H+24
7	B-X σ	Standard deviation of B-X (m)	Float	4	H+32
8	B-Y σ	Standard deviation of B-Y (m)	Float	4	H+36
9	B-Z σ	Standard deviation of B-Z (m)	Float	4	H+40
10	stn ID	Base station identification	Char[4]	4	H+44
11	#obs	Number of observations tracked	Uchar	1	H+48
12	#GPSL1	Number of GPS L1 ranges used in computation	Uchar	1	H+49
13	#L1	Number of GPS L1 ranges above the RTK mask angle	Uchar	1	H+50
14	#L2	Number of GPS L2 ranges above the RTK mask angle	Uchar	1	H+51
15	Reserved		Uchar	1	H+52
16			Uchar	1	H+53
17			Uchar	1	H+54
18			Uchar	1	H+55
30	xxxx	32-bit CRC (ASCII and Binary only)	Hex	4	H+56
31	[CR][LF]	Sentence terminator (ASCII only)	-	-	-

Recommended Input:

log bslnxyza onchanged

ASCII Example:

```
#BSLNXYZA, COM1, 0, 61.5, FINESTEERING, 1264, 508130.000, 00000100, d12a, 1522;  
SOL_COMPUTED, NARROW_INT, -3.2120, 3.0391, 1.2169, 0.0043, 0.0065, 0.0101, "AAAA",  
11, 11, 11, 11, 0, 0, 0, 0*a572d89e
```

3.4.8 CLOCKMODEL Current Clock Model Status

The CLOCKMODEL log contains the current clock-model status of the receiver.

Monitoring the CLOCKMODEL log will allow you to determine the error in your receiver reference oscillator as compared to the GPS satellite reference.

All logs report GPS time not corrected for local receiver clock error. To derive the closest GPS time, subtract the clock offset from the GPS time reported. The clock offset can be calculated by dividing the value of the range bias given in field 6 of the CLOCKMODEL log by the speed of light (c).

The following symbols are used throughout this section:

- B = range bias (m)
- BR = range bias rate (m/s)
- SAB = Gauss-Markov process representing range bias error due to satellite clock dither (m)

The standard clock model now used is as follows:

$$\text{clock parameters array} = [B \quad BR \quad SAB]$$

covariance matrix =

$$\begin{bmatrix} \sigma_B^2 & \sigma_B \sigma_{BR} & \sigma_B \sigma_{SAB} \\ \sigma_{BR} \sigma_B & \sigma_{BR}^2 & \sigma_{BR} \sigma_{SAB} \\ \sigma_{SAB} \sigma_B & \sigma_{SAB} \sigma_{BR} & \sigma_{SAB}^2 \end{bmatrix}$$

Table 49: Clock Model Status

Clock Status (Binary)	Clock Status (ASCII)	Description
0	VALID	The clock model is valid
1	CONVERGING	The clock model is near validity
2	ITERATING	The clock model is iterating towards validity
3	INVALID	The clock model is not valid
4	ERROR	Clock model error

Message ID: 16
Log Type: Synch

Field #	Field type	Data Description	Format	Binary Bytes	Binary Offset
1	header	Log header		H	0
2	clock status	Clock model status as computed from current measurement data, see <i>Table 49, Clock Model Status</i> on Page 173	Enum	4	H
3	reject	Number of rejected range bias measurements	Ulong	4	H+4
4	noise time	GPS time of last noise addition	GPSTime	4	H+8
5	update time	GPS time of last update	GPSTime	4	H+12
6	parameters	Clock correction parameters (a 1x3 array of length 3), listed left-to-right	Double	8	H+16
7				8	H+24
8				8	H+32
9	cov data	Covariance of the straight line fit (a 3x3 array of length 9), listed left-to-right by rows	Double	8	H+40
10				8	H+48
11				8	H+56
12				8	H+64
13				8	H+72
14				8	H+80
15				8	H+88
16				8	H+96
17				8	H+104
18	range bias	Last instantaneous measurement of the range bias (meters)	Double	8	H+112
19	range bias rate	Last instantaneous measurement of the range bias rate (m/s)	Double	8	H+120
20	change	Is there a change in the constellation? 0 = FALSE 1 = TRUE	Enum	4	H+128
21	xxxx	32-bit CRC (ASCII and Binary only)	Hex	4	H+132
22	[CR][LF]	Sentence terminator (ASCII only)	-	-	-

Recommended Input:

log clockmodela ontime 1

ASCII Example:

```
#CLOCKMODELA, COM1, 0, 76.0, FINESTEERING, 1263, 238229.000, 00000000, 98f9, 1522;
VALID, 0, 238229.000, 238229.000, 6.538673273e-01, -5.881929109e-03,
-9.186744290e-01, 1.63780257e+01, 4.435591244e-03, -1.63166399e+01,
4.435591244e-03, 9.830870462e-03, -2.266191182e-03, -1.63166399e+01,
-2.266191182e-03, 1.66873202e+01, -0.268, 1.297410447e-02, FALSE*566e2ac5
```

3.4.9 CLOCKSTEERING Clock Steering Status

The CLOCKSTEERING log is used to monitor the current state of the clock steering process. All oscillators have some inherent drift. By default the receiver attempts to steer the receiver's clock to accurately match GPS time. If for some reason this is not desired, this behavior can be disabled using the CLOCKADJUST command, see *Page 55*.

-
- ☒ If the CLOCKADJUST command is ENABLED, and the receiver is configured to use an external reference frequency (set in the EXTERNALCLOCK command, see *Page 74*, for an external clock - TCXO, OCXO, RUBIDIUM, CESIUM, or USER), then the clock steering process will take over the VARF output pins and may conflict with a previously entered FREQUENCYOUT command, see *Page 81*.
-

Message ID: 26
Log Type: Asynch

Field #	Field type	Data Description	Format	Binary Bytes	Binary Offset
1	header	Log header		H	0
2	source	Clock source, see <i>Table 50, Clock Source on Page 176</i> .	Enum	4	H
3	steeringstate	Steering state, see <i>Table 51, Steering State on Page 176</i> .	Enum	4	H+4
4	period	Period of the FREQUENCYOUT signal used to control the oscillator, refer to the FREQUENCYOUT command. This value is set using the CLOCKCALIBRATE command.	Ulong	4	H+8
5	pulsewidth	Current pulse width of the FREQUENCYOUT signal. The starting point for this value is set using the CLOCKCALIBRATE command. The clock steering loop will continuously adjust this value in an attempt to drive the receiver clock offset and drift terms to zero.	Ulong	4	H+12
6	bandwidth	The current band width of the clock steering tracking loop in Hz. This value is set using the CLOCKCALIBRATE command.	Float	4	H+16
7	slope	The current clock drift change in m/s/bit for a 1 LSB pulse width. This value is set using the CLOCKCALIBRATE command.	Float	4	H+20
8	offset	The last valid receiver clock offset computed (m). It is the same as Field # 18 of the CLOCKMODEL log, see <i>Page 171</i> .	Double	8	H+24
9	driftrate	The last valid receiver clock drift rate received (m/s). It is the same as Field # 19 of the CLOCKMODEL log.	Double	8	H+32
10	xxxx	32-bit CRC (ASCII and Binary only)	Hex	4	H+40
11	[CR][LF]	Sentence terminator (ASCII only)	-	-	-

Recommended Input:

log clocksteering onchanged

ASCII Example:

```
#CLOCKSTEERINGA, COM1, 0, 75.0, FINESTEERING, 1263, 238338.036, 00000000, 0f61, 1522;
INTERNAL, SECOND_ORDER, 4400, 1930.765625000, 0.029999999, -2.000000000,
-0.129, -0.026*e107692f
```

Table 50: Clock Source

Binary	ASCII	Description
0	INTERNAL	The receiver is currently steering its internal VCTCXO using an internal VARF signal.
1	EXTERNAL	The receiver is currently steering an external oscillator using the external VARF signal.

Table 51: Steering State

Binary	ASCII	Description
0	FIRST_ORDER	Upon startup, the clock steering task will adjust the VARF pulse width to reduce the receiver clock drift rate to below 1 ms using a 1st order control loop. This is the normal startup state of the clock steering loop.
1	SECOND_ORDER	Once the receiver has reduced the clock drift to below 1 m/s, it enters a second order control loop and will attempt to reduce the receiver clock offset to zero. This is the normal runtime state of the clock steering process.
2	CALIBRATE_HIGH ^a	This state corresponds to when the calibration process is measuring at the "High" pulse width setting.
3	CALIBRATE_LOW ^a	This state corresponds to when the calibration process is measuring at the "Low" pulse width setting.
4	CALIBRATE_CENTER ^b	This state corresponds to the "Center" calibration process. Once the center has been found, the modulus pulse width, center pulse width, loop bandwidth, and measured slope values are saved in NVM and are used from now on for the currently selected oscillator (INTERNAL or EXTERNAL).

- a. These states will only be seen if you force the receiver to do a clock steering calibration using the CLOCKCALIBRATE command, see *Page 56*. With the CLOCKCALIBRATE command, you can force the receiver to calibrate the slope and center pulse width, of the currently selected oscillator, to steer. The receiver will measure the drift rate at several "High" and "Low" pulse width settings.
- b. After the receiver has measured the "High" and "Low" pulse width setting, the calibration process enters a "Center calibration" process where it attempts to find the pulse width required to zero the clock drift rate.

3.4.10 CMR Standard Logs RTK

CMROBS BASE STATION SATELLITE OBSERVATION INFORMATION

Message ID: 103

CMRREF BASE STATION POSITION INFORMATION

Message ID: 105

CMRDESC BASE STATION DESCRIPTION INFORMATION

Message ID: 310

CMRPLUS CMR+ OUTPUT INFORMATION

Message ID: 717

The Compact Measurement Record (CMR) Format, is a standard communications protocol used in Real-Time Kinematic (RTK) systems to transfer GPS carrier phase and code observations from a base station to one or more rover stations.

The above messages can be logged with an A or B suffix for an ASCII or Binary output with a NovAtel header followed by Hex or Binary raw data respectively.

See the chapter on *Message Formats* in *Volume 1* of this manual set for more information on CMR standard logs.

Example Input:

```
interfacemode com2 none CMR
fix position 51.113 -114.044 1059.4
log com2 cmrobs ontime 2
log com2 cmrref ontime 10
log com2 cmrdesc ontime 10 5
```

3.4.11 CMRDATADESC Base Station Description RTK

See the chapter on *Message Formats* in *Volume 1* of this manual set for information on CMR standard logs.

Message ID: 389

Log Type: Synch

Field #	Field type	Data Description	Format	Binary Bytes	Binary Offset
1	header	Log header	-	H	0
2	CMR header	Synch character for the message	Ulong	4	H
3		Message status	Ulong	4	H+4
4		CMR message type	Ulong	4	H+8
5		Message body length	Ulong	4	H+12
6		Version	Ulong	4	H+16
7		Station ID	Ulong	4	H+20
8		Message Type	Ulong	4	H+24
9		battery	Is the battery low? 0 = FALSE 1 = TRUE	Enum	4
10	memory	Is memory low? 0 = FALSE 1 = TRUE	Enum	4	H+32
11	Reserved		Ulong	4	H+36
12	L2	Is L2 enabled? 0 = FALSE 1 = TRUE	Enum	4	H+40
13	Reserved		Ulong	4	H+44
14	epoch	Epoch time (milliseconds)	Ulong	4	H+48
15	motion	Motion state 0 = UNKNOWN 1 = STATIC 2 = KINEMATIC	Ulong	4	H+52
16	Reserved		Ulong	4	H+56
17	rec length	Record length (bytes). The length altogether of the four fields that follow.	Double	8	H+60
18	short ID	Short station ID. A sequence of eight numbers.	Uchar[8]	8	H+68
19	code	COGO code. A sequence of 16 numbers.	Uchar[16]	16	H+76
20	ID length	Long ID length. The length of the long ID field that follows.	Ulong	4	H+92
21	long ID	Long station ID. Variable length. Check Field #20 above.	Uchar[50]	52 ^a	H+96
22	xxxx	32-bit CRC (ASCII and Binary only)	Hex	4	H+148
23	[CR][LF]	Sentence terminator (ASCII only)	-	-	-

a. In the binary log case an additional 2 bytes of padding are added to maintain 4 byte alignment

Recommended Input:

log cmrdatadesca ontime 10 5

ASCII Example:

```
#CMRDATADESCA,COM1,0,76.5,FINESTEERING,1117,162906.461,00100020,b467,399;
2,0,147,39,3,0,2,
FALSE,FALSE,0,TRUE,0,180000,1,0,33,32,32,32,32,99,114,101,102,0,0,0,0,0,0,
0,0,0,0,0,0,0,0,8,85,78,75,78,79,87,78,0*482add29
```

where the bolded 33 in the example above represents the total length of the records that follow:

Short ID:

32,32,32,32,99,114,101,102, (8 bytes)

COGO Code:

0,0,0,0,0,0,0,0,0,0,0,0,0,0,0,0, (16 bytes)

ID Length:

8, (1 byte)

Long ID:

85,78,75,78,79,87,78,0 (8 bytes)

3.4.12 CMRDATAOBS Base Station Satellite Observations RTK

See the chapter on *Message Formats* in *Volume 1* of this manual set for information on CMR standard logs.

Message ID: 390

Log Type: Synch

Field #	Field type	Data Description	Format	Binary Bytes	Binary Offset
1	header	Log header	-	H	0
2	CMR header	Synch character for the message	Ulong	4	H
3		Message status	Ulong	4	H+4
4		CMR message type	Ulong	4	H+8
5		Message body length	Ulong	4	H+12
6		Version	Ulong	4	H+16
7		Station ID	Ulong	4	H+20
8		Message Type	Ulong	4	H+24
9		#sv	Number of SVs	Ulong	4
10	epoch	Epoch time (milliseconds)	Ulong	4	H+32
11	clock bias	Is clock bias valid? 0 = NOT VALID 3 = VALID	Ulong	4	H+36
12	clock offset	Clock offset (nanoseconds)	Long	4	H+40
13	# obs	Number of satellite observations with information to follow	Ulong	4	H+44
14	prn	Satellite PRN number	Ulong	4	H+48
15	code flag	Is code P Code? 0 = FALSE 1 = TRUE	Enum	4	H+52
16	L1	Is L1 phase valid? 0 = FALSE 1 = TRUE	Enum	4	H+56
17	L2	Is L2 present? 0 = FALSE 1 = TRUE	Enum	4	H+60
18	L1 psr	L1 pseudorange (1/8 L1 cycles)	Ulong	4	H+64
19	L1 carrier	L1 carrier-code measurement (1/256 L1 cycles)	Long	4	H+68
20	L1 S/N ₀	L1 signal-to-noise density ratio	Ulong	4	H+72
21	L1 slip	L1 cycle slip count (number of times that tracking has not been continuous)	Ulong	4	H+76
22	L2 code	Is L2 code available? 0 = FALSE 1 = TRUE	Enum	4	H+80
23	Code type	Is code X-correlation? 0 = FALSE 1 = TRUE	Enum	4	H+84

Continued on Page 181

Field #	Field type	Data Description	Format	Binary Bytes	Binary Offset
24	L2 c valid	Is L2 code valid? 0 = FALSE 1 = TRUE	Enum	4	H+88
25	L2 p valid	Is L2 phase valid? 0 = FALSE 1 = TRUE	Enum	4	H+92
26	phase full	Is phase full? 0 = FALSE 1 = TRUE	Enum	4	H+96
27	Reserved		Ulong	4	H+100
28	L2 r offset	L2 range offset (1/100 meters)	Long	4	H+104
29	L2 c offset	L2 carrier offset (1/256 cycles)	Long	4	H+108
30	L2 S/N ₀	L2 signal-to-noise density ratio	Ulong	4	H+112
31	L2 slip	L2 cycle slip count (number of times that tracking has not been continuous)	Ulong	4	H+116
32...	Next PRN offset = H+48 + (#prns x 72)				
variable	xxxx	32-bit CRC (ASCII and Binary only)	Hex	4	variable
variable	[CR][LF]	Sentence terminator (ASCII only)	-	-	-

Recommended Input:

```
log cmrdataobsa ontime 2
```

ASCII Example:

```
#CMRDATAOBSA, COM1, 0, 74.0, FINESTEERING, 1117, 162981.000, 00100020, b222, 399;
2, 0, 147, 93, 3, 0, 0,
10, 21000, 3, 0, 10,
3, FALSE, TRUE, TRUE, 8684073, -505, 10, 1, TRUE, TRUE, TRUE, TRUE, TRUE, 0, 368, -512, 11, 1,
15, FALSE, TRUE, TRUE, 11936394, 129, 11, 1, TRUE, TRUE, TRUE, TRUE, TRUE, 0, 270, 78, 12, 1,
18, FALSE, TRUE, TRUE, 5334926, 186, 11, 1, TRUE, TRUE, TRUE, TRUE, TRUE, 0, 164, 164, 12, 1,
21, FALSE, TRUE, TRUE, 10590427, -770, 10, 1, TRUE, TRUE, TRUE, TRUE, TRUE, 0,
366, -850, 11, 1,
17, FALSE, TRUE, TRUE, 3262859, 32, 11, 1, TRUE, TRUE, TRUE, TRUE, TRUE, 0, 325, 216, 12, 1,
26, FALSE, TRUE, TRUE, 211264, 1213, 10, 1, TRUE, TRUE, TRUE, TRUE, TRUE, 0, 390, 1069, 10, 1,
23, FALSE, TRUE, TRUE, 8098, 209, 11, 1, TRUE, TRUE, TRUE, TRUE, TRUE, 0, 265, 236, 12, 1,
28, FALSE, TRUE, TRUE, 5090047, -160, 6, 1, TRUE, TRUE, TRUE, TRUE, TRUE, 0, 535, -227, 9, 1,
31, FALSE, TRUE, TRUE, 1857322, -1027, 7, 1, TRUE, TRUE, TRUE, TRUE, TRUE, 0,
513, -1063, 8, 1,
9, FALSE, TRUE, TRUE, 51623, -1245, 6, 1, TRUE, TRUE, TRUE, TRUE, TRUE, 0,
599, -1244, 9, 1*9fe706b0
```

3.4.13 CMRDATAREF Base Station Position RTK

Refer to the chapter on *Message Formats* in *Volume 1* of this manual set for information on CMR standard logs. See *Figure 8, Page 170* for a definition of the ECEF coordinates.

Message ID: 391
Log Type: Synch

Field #	Field type	Data Description	Format	Binary Bytes	Binary Offset
1	header	Log header	-	H	0
2	CMR header	Synch character for the message	Ulong	4	H
3		Message status	Ulong	4	H+4
4		CMR message type	Ulong	4	H+8
5		Message body length	Ulong	4	H+12
6		Version	Ulong	4	H+16
7		Station ID	Ulong	4	H+20
8		Message Type	Ulong	4	H+24
9		battery	Is the battery low? 0 = FALSE 1 = TRUE	Enum	4
10	memory	Is memory low? 0 = FALSE 1 = TRUE	Enum	4	H+32
11	Reserved		Ulong	4	H+36
12	L2	Is L2 enabled? 0 = FALSE 1 = TRUE	Enum	4	H+40
13	Reserved		Ulong	4	H+44
14	epoch	Epoch time (milliseconds)	Ulong	4	H+48
15	motion	Motion state: 0 = UNKNOWN 1 = STATIC 2 = KINEMATIC	Ulong	4	H+52
16	Reserved		Ulong	4	H+56
17	ECEF-X	Reference ECEF-X position (millimeters)	Double	8	H+60
18	ant hgt	Antenna height (millimeters)	Ulong	4	H+68
19	ECEF-Y	Reference ECEF-Y position (millimeters)	Double	8	H+72
20	e offset	Easting offset (millimeters)	Ulong	4	H+80
21	ECEF-Z	Reference ECEF-Z position (millimeters)	Double	8	H+84
22	n offset	Northing offset (millimeters)	Ulong	4	H+92
23	pos acc	Position accuracy relative to WGS84, see <i>Table 52, Position Accuracy on Page 183</i>	Ulong	4	H+96
24	Reserved		Ulong	4	H+100
25	xxxx	32-bit CRC (ASCII and Binary only)	Hex	4	H+104
26	[CR][LF]	Sentence terminator (ASCII only)	-	-	-

Recommended Input:

```
log cmrdatarefa ontime 10
```

ASCII Example:

```
#CMRDATAAREFA, COM1, 0, 70.0, FINESTEERING, 1269, 147115.000, 00100000, 5db6, 1516;
2, 0, 147, 25, 3, 0, 1, FALSE, FALSE, 0, TRUE, 0, 234000, 1, 0,
-1634529233.1026337146759033, 0, -3664611941.5660152435302734, 0,
-2054717277, 0, 15, 0*c21a9c26
```

Table 52: Position Accuracy

Code	Position Accuracy
0	unknown
1	5 km
2	1 km
3	500 m
4	100 m
5	50 m
6	10 m
7	5 m
8	1 m
9	50 cm
10	10 cm
11	5 cm
12	1 cm
13	5 mm
14	1 mm
15	Exact

3.4.14 CMRPLUS CMR+ Output Message RTK

The CMRPLUS message distributes the reference station information over 14 updates. For example, if you log:

```
CMRPLUS ontime 1
```

the receiver outputs the complete reference station information in 14 seconds.

Refer to the chapter on *Message Formats* in *Volume 1* of this manual set for information on CMR standard logs.

Message ID: 717
Log Type: Asynch

Field #	Field type	Data Description	Format	Binary Bytes	Binary Offset
1	header	Log header	-	H	0
2	CMR header	Synch character for the message	Ulong	4	H
3		Message status	Ulong	4	H+4
4		CMR message type	Ulong	4	H+8
5		Message body length	Ulong	4	H+12
6		Version	Ulong	4	H+16
7		Station ID	Ulong	4	H+20
8		Message Type	Ulong	4	H+24
9	stnID	Station ID	Ulong	4	H+28
10	page	Current page index	Ulong	4	H+32
11	#pages	Maximum number of page indexes	Ulong	4	H+36
12	data	Data for this page	Uchar[7]	8 ^a	H+40
13	xxxx	32-bit CRC (ASCII and Binary only)	Hex	4	H+104
14	[CR][LF]	Sentence terminator (ASCII only)	-	-	-

a. In the binary log case an additional byte of padding is added to maintain 4 byte alignment

Recommended Input:

```
log cmrplusa ontime 1
```

ASCII Example:

```
#CMRPLUSA,COM1,0,83.0,FINESTEERING,1317,318534.915,00180040,30aa,1855;  
2,0,148,10,0,4,14,1b,00,00,00,00,62,61*64e0c9ea
```

3.4.15 COMCONFIG Current COM Port Configuration

This log will output the current COM port configuration for each port on your receiver.

Message ID: 317

Log Type: Polled

Field #	Field type	Data Description	Format	Binary Bytes	Binary Offset
1	header	Log header		H	0
2	#port	Number of ports with information to follow	Long	4	H
3	port	Serial port identifier, see <i>Table 15, COM Serial Port Identifiers on Page 60</i>	Enum	4	H+4
4	baud	Communication baud rate	Ulong	4	H+8
5	parity	See <i>Table 16, Parity on Page 60</i>	Enum	4	H+12
6	databits	Number of data bits	Ulong	4	H+16
7	stopbits	Number of stop bits	Ulong	4	H+20
8	handshake	See <i>Table 17, Handshaking on Page 60</i>	Enum	4	H+24
9	echo	When echo is on, the port is transmitting any input characters as they are received. 0 = OFF 1 = ON	Enum	4	H+28
10	breaks	Breaks are turned on or off 0 = OFF 1 = ON	Enum	4	H+32
11	rx type	The status of the receive interface mode, see <i>Table 28, Serial Port Interface Modes on Page 88</i>	Enum	4	H+36
12	tx type	The status of the transmit interface mode, <i>Table 28, Serial Port Interface Modes on Page 88</i>	Enum	4	H+40
13	response	Responses are turned on or off 0 = OFF 1 = ON	Enum	4	H+44
14	next port offset = H + 4 + (#port x 44)				
15	xxxx	32-bit CRC (ASCII and Binary only)	Hex	4	H+4+ (#port x 44)
16	[CR][LF]	Sentence terminator (ASCII only)	-	-	-

Recommended Input:

```
log comconfiga once
```

ASCII example:

```
#COMCONFIGA, COM1, 0, 73.5, FINESTEERING, 1263, 238521.473, 00000000, 85aa, 1522;
3,
COM1, 9600, N, 8, 1, CTS, OFF, ON, NOVATEL, NOVATEL, ON,
COM2, 9600, N, 8, 1, N, OFF, ON, RTCA, NONE, ON,
COM3, 9600, N, 8, 1, N, OFF, ON, NOVATEL, NOVATEL, ON*39b122de
```

3.4.16 GPALM Almanac Data NMEA

This log outputs raw almanac data for each satellite PRN contained in the broadcast message. A separate record is logged for each PRN, up to a maximum of 32 records. Following a receiver reboot, no records are output until new broadcast message data is received from a satellite. It takes a minimum of 12.5 minutes to collect a complete almanac following receiver boot-up. If an almanac was stored in NVM, the stored values are reported in the GPALM log once time is set on the receiver.

Message ID: 217

Log Type: Asynch

Field	Structure	Field Description	Symbol	Example
1	\$GPALM	Log header		\$GPALM
2	# msg	Total number of messages logged. Set to zero until almanac data is available.	x.x	17
3	msg #	Current message number	x.x	17
4	PRN	Satellite PRN number: GPS = 1 to 32 SBAS = 33 to 64 (add 87 for PRN number)	xx	28
5	GPS wk	GPS reference week number ^a .	x.x	653
6	SV hlth	SV health, bits 17-24 of each almanac page ^b	hh	00
7	ecc	e, eccentricity ^{c d}	hhhh	3EAF
8	alm ref time	toa, almanac reference time ^c	hh	87
9	incl angle	(sigma) _i , inclination angle ^c	hhhh	OD68
10	omegadot	OMEGADOT, rate of right ascension ^c	hhhh	FD30
11	rt axis	(A) ^{1/2} , root of semi-major axis ^c	hhhhhh	A10CAB
12	omega	omega, argument of perigee ^{c e}	hhhhhh	6EE732
13	long asc node	(OMEGA) _o , longitude of ascension node ^c	hhhhhh	525880
14	M _o	Mo, mean anomaly ^c	hhhhhh	6DC5A8
15	af0	af0, clock parameter ^c	hhh	009
16	af1	af1, clock parameter ^c	hhh	005
17	*xx	Checksum	*hh	*37
18	[CR][LF]	Sentence terminator		[CR][LF]

- a Variable length integer, 4-digits maximum from (2) most significant binary bits of Subframe 1, Word 3 reference Table 20-I, ICD-GPS-200, Rev. B, and (8) least significant bits from subframe 5, page 25, word 3 reference Table 20-I, ICD-GPS-200¹
- b Reference paragraph 20.3.3.5.1.3, Table 20-VII and Table 20-VIII, ICD-GPS-200, Rev. B
- c Reference Table 20-VI, ICD-GPS-200, Rev. B for scaling factors and units.
- d A quantity defined for a conic section where e= 0 is a circle, e = 1 is an ellipse, 0<e<1 is a parabola and e>1 is a hyperbola.
- e A measurement along the orbital path from the ascending node to the point where the SV is closest to the Earth, in the direction of the SV's motion.

1. To obtain copies of ICD-GPS-200, refer to ARINC in the *Standards and References* section of the *GPS+ Reference Manual* available on our website. Refer also to NMEA contact information there.

Recommended Input:

log gpalm onchanged

Example:

```
$GPALM,24,01,25,0000,ff,0000,00,0243,0000,ffffff,ffffff,ffffff,000000,000,000  
,*52
```

3.4.17 GPGGA GPS Fix Data and Undulation NMEA

Time, position and fix-related data of the GPS receiver. For greater precision, but with the loss of the undulation fields, use the GPGGARTK log (see *Page 190*). See also *Table 53, Position Precision of NMEA Logs on Page 194*.

This log will output null data in all fields until a valid almanac is obtained.

Message ID: 218

Log Type: Synch

Field	Structure	Field Description	Symbol	Example
1	\$GPGGA	Log header		\$GPGGA
2	utc	UTC time of position (hours/minutes/seconds/ decimal seconds)	hhmmss.ss	202134.00
3	lat	Latitude (DDmm.mm)	llll.ll	5106.9847
4	lat dir	Latitude direction (N = North, S = South)	a	N
5	lon	Longitude (DDDmm.mm)	yyyyy.yy	11402.2986
6	lon dir	Longitude direction (E = East, W = West)	a	W
7	GPS qual	GPS Quality indicator 0 = Fix not available or invalid 1 = GPS fix 2 = C/A differential GPS, OmniSTAR VBS or CDGPS 4 = RTK fixed ambiguity solution (RT2) 5 = RTK floating ambiguity solution (RT20), OmniSTAR HP or OmniSTAR XP 9 = WAAS ^b	x	1
8	# sats	Number of satellites in use (00-12). May be different to the number in view	xx	10
9	hdop	Horizontal dilution of precision	x.x	1.0
10	alt	Antenna altitude above/below mean sea level (geoid)	x.x	1062.22
11	a-units	Units of antenna altitude (M = meters)	M	M
12	undulation	Undulation - the relationship between the geoid and the WGS84 ellipsoid	x.x	-16.271
13	u-units	Units of undulation (M = meters)	M	M
14	age	Age of Differential GPS data (in seconds) ^a	xx	..
15	stn ID	Differential base station ID, 0000-1023	xxxx	..
16	*xx	Checksum	*hh	*48
17	[CR][LF]	Sentence terminator		[CR][LF]

a The maximum age reported here is limited to 99 seconds.

b An indicator of 9 has been temporarily set for WAAS. The NMEA standard for WAAS has not been decided yet.

Recommended Input:

log gpgga ontime 1

Example:

\$GPGGA,202134.00,5106.9847,N,11402.2986,W,1,10,1.0,1062.22,M,-16.27,M,,*61

3.4.18 GPGGALONG Fix Data, Extra Precision and Undulation NMEA

Time, position, undulation and fix-related data of the GPS receiver. This is output as a GPGGA log but the GPGGALONG log differs from the normal GPGGA log by its extra precision. See also *Table 53, Position Precision of NMEA Logs on Page 194*.

This log will output null data in all fields until a valid almanac is obtained.

Message ID: 521
Log Type: Synch

Field	Structure	Field Description	Symbol	Example
1	\$GPGGA	Log header		\$GPGGA
2	utc	UTC time of position (hours/minutes/seconds/ decimal seconds)	hhmmss.ss	202126.00
3	lat	Latitude (DDmm.mm)	llll.ll	5106.9847029
4	lat dir	Latitude direction (N = North, S = South)	a	N
5	lon	Longitude (DDDmm.mm)	yyyyy.yy	11402.2986286
6	lon dir	Longitude direction (E = East, W = West)	a	W
7	GPS qual	GPS Quality indicator 0 = Fix not available or invalid 1 = GPS fix 2 = C/A differential GPS, OmniSTAR VBS or CDGPS 4 = RTK fixed ambiguity solution (RT2) 5 = RTK floating ambiguity solution (RT20), OmniSTAR HP or OmniSTAR XP 9 = WAAS ^b	x	1
8	# sats	Number of satellites in use (00-12). May be different to the number in view	xx	10
9	hdop	Horizontal dilution of precision	x.x	1.0
10	alt	Antenna altitude above/below mean sea level (geoid)	x.x	1062.376
11	units	Units of antenna altitude (M = meters)	M	M
12	undulation	Undulation - the relationship between the geoid and the WGS84 ellipsoid	x.x	-16.271
13	u-units	Units of undulation (M = meters)	M	M
14	age	Age of Differential GPS data (in seconds) ^a	xx	„
15	stn ID	Differential base station ID, 0000-1023	xxxx	„
16	*xx	Checksum	*hh	*48
17	[CR][LF]	Sentence terminator		[CR][LF]

a The maximum age reported here is limited to 99 seconds.

b An indicator of 9 has been temporarily set for WAAS. The NMEA standard for WAAS has not been decided yet.

Recommended Input:

log gpggalong ontime 1

Example:

```
$GPGGA,2.02,126.00,5.106,9847029,N,11402.2986286,W,1,10,1.0,1062.376,  
M,-16.27,M,,*57
```

3.4.19 GPGGARTK Global Position System Fix Data NMEA

Time, position and fix-related data of the GPS receiver. This is output as a GPGGA log but the GPGGARTK log differs from the normal GPGGA log by its extra precision. In order for the position to be output with this extra precision, the undulation fields are unavailable (see the GPGGA log on Page 188). See also Table 53, *Position Precision of NMEA Logs* on Page 194.

This log will output null data in all fields until a valid almanac is obtained.

Message ID: 259
Log Type: Synch

Field	Structure	Field Description	Symbol	Example
1	\$GPGGA	Log header		\$GPGGA
2	utc	UTC time of position (hours/minutes/seconds/ decimal seconds)	hhmmss.ss	220147.50
3	lat	Latitude (DDmm.mm)	llll.ll	5106.7194489
4	lat dir	Latitude direction (N = North, S = South)	a	N
5	lon	Longitude (DDDmm.mm)	yyyyy.yy	11402.3589020
6	lon dir	Longitude direction (E = East, W = West)	a	W
7	GPS qual	GPS Quality indicator 0 = Fix not available or invalid 1 = GPS fix 2 = C/A differential GPS, OmniSTAR VBS or CDGPS 4 = RTK fixed ambiguity solution (RT2) 5 = RTK floating ambiguity solution (RT20), OmniSTAR HP or OmniSTAR XP 9 = WAAS ^b	x	1
8	# sats	Number of satellites in use (00-12). May be different to the number in view	xx	08
9	hdop	Horizontal dilution of precision	x.x	0.9
10	alt	Antenna altitude above/below mean sea level (geoid)	x.x	1080.406
11	units	Units of antenna altitude (M = meters)	M	M
12	null	(This field not available on OEM4 family receivers)		„
13	null	(This field not available on OEM4 family receivers)		„
14	age	Age of Differential GPS data (in seconds) ^a	xx	„
15	stn ID	Differential base station ID, 0000-1023	xxxx	„
16	*xx	Checksum	*hh	*48
17	[CR][LF]	Sentence terminator		[CR][LF]

a The maximum age reported here is limited to 99 seconds.

b An indicator of 9 has been temporarily set for WAAS. The NMEA standard for WAAS has not been decided yet.

Recommended Input:

log gpggartk ontime 1

Example:

```
$GPGGA,182053.00,5106.9802878,N,11402.3037361,W,4,07,1.1,1048.237,M,,02,  
AAAA*18
```

3.4.20 GPGLL Geographic Position NMEA

Latitude and longitude of present vessel position, time of position fix, and status.

Table 53 compares the position precision of selected NMEA logs.

This log will output null data in all fields until a valid almanac is obtained.

Message ID: 219

Log Type: Synch

Field	Structure	Field Description	Symbol	Example
1	\$GPGLL	Log header		\$GPGLL
2	lat	Latitude (DDmm.mm)	llll.ll	5106.7198674
3	lat dir	Latitude direction (N = North, S = South)	a	N
4	lon	Longitude (DDDmm.mm)	yyyyy.yy	11402.3587526
5	lon dir	Longitude direction (E = East, W = West)	a	W
6	utc	UTC time of position (hours/minutes/seconds/decimal seconds)	hhmmss.ss	220152.50
7	data status	Data status: A = Data valid, V = Data invalid	A	A
8	*xx	Checksum	*hh	*1B
9	[CR][LF]	Sentence terminator		[CR][LF]

Recommended Input:

log gppll ontime 1

Example:

\$GPGLL,5106.9802869,N,11402.3037325,W,182147.00,A*1C

Table 53: Position Precision of NMEA Logs

NMEA Log	Latitude (# of decimal places)	Longitude (# of decimal places)	Altitude (# of decimal places)
GPGBA	4	4	2
GPGBALONG	7	7	3
GPGBARTK	7	7	3
GPGLL	7	7	N/A
GPRMC	7	7	N/A

3.4.21 GPGRS GPS Range Residuals for Each Satellite NMEA

Range residuals can be computed in two ways, and this log reports those residuals. Under mode 0, residuals output in this log are used to update the position solution output in the GPGLA message. Under mode 1, the residuals are re-computed after the position solution in the GPGLA message is computed. The receiver computes range residuals in mode 1. An integrity process using GPGRS would also require GPGLA (for position fix data), GPGLA (for DOP figures), and GPGLV (for PRN numbers) for comparative purposes.

This log will output null data in all fields until a valid almanac is obtained.

Message ID: 220
Log Type: Synch

Field	Structure	Field Description	Symbol	Example
1	\$GPGRS	Log header		\$GPGRS
2	utc	UTC time of position (hours/minutes/seconds/decimal seconds)	hhmmss.ss	192911.0
3	mode	Mode 0 =residuals were used to calculate the position given in the matching GGA line (apriori) (not used by OEM4 family receiver) Mode 1 =residuals were recomputed after the GGA position was computed (preferred mode)	x	1
4 - 15	res	Range residuals for satellites used in the navigation solution. Order matches order of PRN numbers in GPGLA.	x.x,x.x,.....	-13.8,-1.9,11.4,-33.6,0.9,6.9,-12.6,0.3,0.6, -22.3
16	*xx	Checksum	*hh	*65
17	[CR][LF]	Sentence terminator		[CR][LF]

Recommended Input:

log gprgs ontime 1

Example:

```
$GPGRS,182215.00,1,-0.0,-0.0,-0.2,0.0,0.0,0.2,-0.0,0.1,,,,*42
```

-
- ☒ 1. If the range residual exceeds ± 99.9 , then the decimal part will be dropped. Maximum value for this field is ± 999 . The sign of the range residual is determined by the order of parameters used in the calculation as follows:

$$\text{range residual} = \text{calculated range} - \text{measured range}$$
 - 2. There is no residual information available from the OmniSTAR HP service, so the GPGLS contains the pseudorange position values when using it. For the OmniSTAR VBS or CDGPS service, residual information is available.
-

3.4.22 GPGSA GPS DOP and Active Satellites NMEA

GPS receiver operating mode, satellites used for navigation and DOP values.

This log will output null data in all fields until a valid almanac is obtained.

Message ID: 221

Log Type: Synch

Field	Structure	Field Description	Symbol	Example
1	\$GPGSA	Log header		\$GPGSA
2	mode MA	A = Automatic 2D/3D M = Manual, forced to operate in 2D or 3D	M	M
3	mode 123	Mode: 1 = Fix not available; 2 = 2D; 3 = 3D	x	3
4 - 15	prn	PRN numbers of satellites used in solution (null for unused fields), total of 12 fields GPS = 1 to 32 SBAS = 33 to 64 (add 87 for PRN number)	xx,xx,.....	18,03,13,25,16 , 24,12,20,,,,
16	pdop	Position dilution of precision	x.x	1.5
17	hdop	Horizontal dilution of precision	x.x	0.9
18	vdop	Vertical dilution of precision	x.x	1.2
19	*xx	Checksum	*hh	*3F
20	[CR][LF]	Sentence terminator		[CR][LF]

Recommended Input:

log gpgsa ontime 1

Example:

\$GPGSA,M,3,04,10,25,24,05,13,17,30,,,,,2.0,1.6,1.7*3B

3.4.23 GPGST Pseudorange Measurement Noise Statistics NMEA

Pseudorange measurement noise statistics are translated in the position domain in order to give statistical measures of the quality of the position solution.

This log reflects the accuracy of the solution type used in the BESTPOS, see *Page 161*, and GPGBA, see *Page 188*, logs except for the RMS field. The RMS field, since it specifically relates to pseudorange inputs, does not represent carrier-phase based positions. Instead it reflects the accuracy of the pseudorange position which is given in the PSRPOS log, see *Page 231*.

This log will output null data in all fields until a valid almanac is obtained.

Message ID: 222
Log Type: Synch

Field	Structure	Field Description	Symbol	Example
1	\$GPGST	Log header		\$GPGST
2	utc	UTC time of position (hours/minutes/seconds/ decimal seconds)	hhmmss.ss	173653.00
3	rms	RMS value of the standard deviation of the range inputs to the navigation process. Range inputs include pseudoranges and DGPS corrections.	x.x	2.73
4	smjr std	Standard deviation of semi-major axis of error ellipse (meters)	x.x	2.55
5	smnr std	Standard deviation of semi-minor axis of error ellipse (meters)	x.x	1.88
6	orient	Orientation of semi-major axis of error ellipse (degrees from true north)	x.x	15.2525
7	lat std	Standard deviation of latitude error (meters)	x.x	2.51
8	lon std	Standard deviation of longitude error (meters)	x.x	1.94
9	alt std	Standard deviation of altitude error (meters)	x.x	4.30
10	*xx	Checksum	*hh	*6E
11	[CR][LF]	Sentence terminator		[CR][LF]

Recommended Input:

log gpgst ontime 1

Example:

\$GPGST,182310.00,1.18,0.01,0.01,125.6569,0.01,0.01,0.02*6E

3.4.24 GPGSV GPS Satellites in View NMEA

Number of SVs in view, PRN numbers, elevation, azimuth and SNR value. Four satellites maximum per message. When required, additional satellite data sent in 2 or more messages (a maximum of 9). The total number of messages being transmitted and the current message being transmitted are indicated in the first two fields.

This log outputs null data in all fields until a valid almanac is obtained.

- ☒ 1. Satellite information may require the transmission of multiple messages. The first field specifies the total number of messages, minimum value 1. The second field identifies the order of this message (message number), minimum value 1.
- 2. A variable number of 'PRN-Elevation-Azimuth-SNR' sets are allowed up to a maximum of four sets per message. Null fields are not required for unused sets when less than four sets are transmitted.

Message ID: 223
Log Type: Synch

Field	Structure	Field Description	Symbol	Example
1	\$GPGSV	Log header		\$GPGSV
2	# msgsv	Total number of messages (1-9)	x	3
3	msg #	Message number (1-9)	x	1
4	# sats	Total number of satellites in view	xx	09
5	prn	Satellite PRN number GPS = 1 to 32 SBAS = 33 to 64 (add 87 for PRN number)	xx	03
6	elev	Elevation, degrees, 90 maximum	xx	51
7	azimuth	Azimuth, degrees True, 000 to 359	xxx	140
8	SNR	SNR (C/N ₀) 00-99 dB, null when not tracking	xx	42
...	...	Next satellite PRN number, elev, azimuth, SNR,		
...		
...	...	Last satellite PRN number, elev, azimuth, SNR,		
variable	*xx	Checksum	*hh	*72
variable	[CR][LF]	Sentence terminator		[CR][LF]

Recommended Input:

log gpgsv ontime 1

Example:

```
$GPGSV,3,1,10,17,76,200,50,24,60,063,50,30,58,266,50,05,45,189,48*7B
$GPGSV,3,2,10,06,41,287,,10,39,143,47,04,20,058,42,25,13,314,39*7D
$GPGSV,3,3,10,13,07,050,41,01,04,014,*7D
```

3.4.25 GPRMB Navigation Information NMEA

Navigation data from present position to a destination waypoint. The destination is set active by the receiver SETNAV command. If SETNAV has been set, a command to log either GPRMB or GPRMC will cause both logs to output data.

This log will output null data in all fields until a valid almanac is obtained.

Message ID: 224

Log Type: Synch

Field	Structure	Field Description	Symbol	Example
1	\$GPRMB	Log header		\$GPRMB
2	data status	Data status: A = data valid; V = navigation receiver warning	A	V
3	xtrack	Cross track error ^a	x.x	0.011
4	dir	Direction to steer to get back on track (L/R) ^b	a	L
5	origin ID	Origin waypoint ID ^c	c--c	START
6	dest ID	Destination waypoint ID ^c	c--c	END
7	dest lat	Destination waypoint latitude (DDmm.mm) ^c	llll.ll	5106.7074000
8	lat dir	Latitude direction (N = North, S = South) ^c	a	N
9	dest lon	Destination waypoint longitude (DDDmm.mm) ^c	yyyyy.yy	11402.349
10	lon dir	Longitude direction (E = East, W = West) ^c	a	E
11	range	Range to destination, nautical miles ^d	x.x	0.0127611
12	bearing	Bearing to destination, degrees True	x.x	153.093
13	vel	Destination closing velocity, knots	x.x	0.3591502
14	arr status	Arrival status: A = perpendicular passed V = destination not reached or passed	A	V
15	*xx	Checksum	*hh	*13
16	[CR][LF]	Sentence terminator		[CR][LF]

- a - If cross track error exceeds 9.99 NM, display 9.99
- Represents track error from intended course
- One nautical mile = 1,852 meters
- b Direction to steer is based on the sign of the crosstrack error, that is, L = xtrack error (+); R = xtrack error (-)
- c Fields 5, 6, 7, 8, 9, and 10 are tagged from the SETNAV command, see *Page 121*.
- d If range to destination exceeds 999.9 NM, display 999.9

Recommended Input:

log gprmb ontime 1

Example:

```
$GPRMB,A,0.07,R,BASE,CDNW,5103.9420000,N,11401.3380000,W,3.1,168.7,0.0,V*39
```

3.4.26 GPRMC GPS Specific Information NMEA

Time, date, position, track made good and speed data provided by the GPS navigation receiver. RMC and RMB are the recommended minimum navigation data to be provided by a GPS receiver.

A comparison of the position precision between this log and other selected NMEA logs can be seen in *Table 53, Position Precision of NMEA Logs on Page 194*.

This log will output null data in all fields until a valid almanac is obtained.

Message ID: 225

Log Type: Synch

Field	Structure	Field Description	Symbol	Example
1	\$GPRMC	Log header		\$GPRMC
2	utc	UTC of position	hhmmss.ss	140437.00
3	pos status	Position status: A = data valid V = data invalid	A	A
4	lat	Latitude (DDmm.mm)	llll.ll	5106.9850961
5	lat dir	Latitude direction (N = North, S = South)	a	N
6	lon	Longitude (DDDmm.mm)	yyyyy.yy	11402.2998978
7	lon dir	Longitude direction (E = East, W = West)	a	W
8	speed Kn	Speed over ground, knots	x.x	0.046
9	track true	Track made good, degrees True	x.x	336.8
10	date	Date: dd/mm/yy	xxxxxx	060504
11	mag var	Magnetic variation, degrees ^b	x.x	16.0
12	var dir	Magnetic variation direction E/W ^a	a	E
13	*xx	Checksum	*hh	*71
14	[CR][LF]	Sentence terminator		[CR][LF]

- a Easterly variation (E) subtracts from True course
Westerly variation (W) adds to True course
- b Note that this field is the actual magnetic variation East or West and is the inverse sign of the value entered into the *MAGVAR* command, see *Page 93* for more information.

Recommended Input:

log gprmc ontime 1

Example:

```
$GPRMC,140437.00,A,5106.9850961,N,11402.2998978,W,0.046,336.8,060504,
16.0,E*71
```

3.4.27 GPSEPHM Decoded GPS Ephemerides

A single set of GPS ephemeris parameters.

Message ID: 7

Log Type: Asynch

Field#	Field type	Data Description	Format	Binary Bytes	Binary Offset
1	header	Log header		H	0
2	PRN	Satellite PRN number	Ulong	4	H
3	tow	Time stamp of subframe 0 (seconds)	Double	8	H+4
4	health	Health status - a 6-bit health code as defined in ICD-GPS-200 ^a	Ulong	4	H+12
5	IODE1	Issue of ephemeris data 1	Ulong	4	H+16
6	IODE2	Issue of ephemeris data 2	Ulong	4	H+20
7	week	GPS week number	Ulong	4	H+24
8	z week	Z count week number. This is the week number from subframe 1 of the ephemeris. The 'toe week' (field #7) is derived from this to account for rollover.	Ulong	4	H+28
9	toe	Reference time for ephemeris, seconds	Double	8	H+32
10	A	Semi-major axis, meters	Double	8	H+40
11	ΔN	Mean motion difference, radians/second	Double	8	H+48
12	M_0	Mean anomaly of reference time, radians	Double	8	H+56
13	ecc	Eccentricity, dimensionless - quantity defined for a conic section where $e = 0$ is a circle, $e = 1$ is an ellipse, $0 < e < 1$ is a parabola and $e > 1$ is a hyperbola.	Double	8	H+64
14	ω	Argument of perigee, radians - measurement along the orbital path from the ascending node to the point where the SV is closest to the Earth, in the direction of the SV's motion.	Double	8	H+72
15	cuc	Argument of latitude (amplitude of cosine, radians)	Double	8	H+80
16	cus	Argument of latitude (amplitude of sine, radians)	Double	8	H+88
17	crc	Orbit radius (amplitude of cosine, meters)	Double	8	H+96
18	crs	Orbit radius (amplitude of sine, meters)	Double	8	H+104
19	cic	Inclination (amplitude of cosine, radians)	Double	8	H+112
20	cis	Inclination (amplitude of sine, radians)	Double	8	H+120
21	I_0	Inclination angle at reference time, radians	Double	8	H+128
22	\dot{I}	Rate of inclination angle, radians/second	Double	8	H+136
23	ω_0	Right ascension, radians	Double	8	H+144
24	$\dot{\omega}$	Rate of right ascension, radians/second	Double	8	H+152
25	iodc	Issue of data clock	Ulong	4	H+160
26	toc	SV clock correction term, seconds	Double	8	H+164
27	tgdc	Estimated group delay difference, seconds	Double	8	H+172
28	a_{f0}	Clock aging parameter, seconds (s)	Double	8	H+180
29	a_{f1}	Clock aging parameter, (s/s)	Double	8	H+188

Continued on Page 202

Field#	Field type	Data Description	Format	Binary Bytes	Binary Offset
30	a _{f2}	Clock aging parameter, (s/s/s)	Double	8	H+196
31	AS	Anti-spoofing on: 0 = FALSE 1 = TRUE	Enum	4	H+204
32	N	Corrected mean motion, radians/second	Double	8	H+208
33	URA	User Range Accuracy variance, m ² . The ICD ^a specifies that the URA index transmitted in the ephemerides can be converted to a nominal standard deviation value using an algorithm listed there. We publish the square of the nominal value (variance). The correspondence between the original URA index and the value output is shown in <i>Table 54</i> .	Double	8	H+216
34	xxxx	32-bit CRC (ASCII and Binary only)	Hex	4	H+224
35	[CR][LF]	Sentence terminator (ASCII only)	-	-	-

- a. To obtain copies of ICD-GPS-200, refer to ARINC in the *Standards and References* section of the *GPS+ Reference Manual* available on our website at <http://www.novatel.com/support/docupdates.htm>.

Table 54: URA Variance

Index Value (m)	A: Standard Deviations (m)	Variance: A ² (m ²)
0	2.0	4
1	2.8	7.84
2	4.0	16
3	5.7	32.49
4	8	56
5	11.3	127.69
6	16.0	256
7	32.0	1024
8	64.0	4096
9	128.0	16384
10	256.0	65536
11	512.0	262144
12	1024.0	1048576
13	2048.0	4194304
14	4096.0	16777216
15	8192.0	67108864

Recommended Input:

log gpsephema onchanged

ASCII Example:

```
#GPSEPHEMA, COM1, 14, 81.0, ERROR, 0, 0.000, 00000000, 9145, 1522;
6, 423540.0, 63, 64, 64, 1262, 1262, 424800.0, 2.655894033e+07,
5.534516249e-09, -1.429148032e+00, 6.2850565882e-03,
-2.026795978e+00, 2.393499017e-06, 4.608184099e-06,
2.74125000e+02, 4.30625000e+01, 1.285225153e-07, 1.117587090e-07,
9.3598975235e-01, 4.150172871e-10, 1.081912914e+00, -8.60571561e-09,
64, 424800.0, -4.656612873e-09, -2.94484e-06, -1.13687e-12, 0.00000,
TRUE, 1.458711083e-04, 4.00000000e+00*09a3a5e2
...
#GPSEPHEMA, COM1, 0, 81.0, SATTIME, 1263, 239730.000, 00000000, 9145, 1522;
13, 239730.0, 0, 160, 160, 1263, 1263, 244800.0, 2.656060392e+07,
3.876590047e-09, 1.087692891e+00, 2.1466212347e-03,
6.7361097243e-01, 1.648440957e-06, 9.942799807e-06,
1.98843750e+02, 3.36250000e+01, -1.005828381e-07, 1.862645149e-09,
9.8247586002e-01, 3.671581508e-10, -2.155392355e+00, -7.69817780e-09,
160, 244800.0, -1.117587090e-08, -3.03681e-05, 3.41061e-13,
0.00000, TRUE, 1.458557464e-04, 4.00000000e+00*2a0020bb
```

3.4.28 GPVTG Track Made Good And Ground Speed NMEA

The track made good and speed relative to the ground.

This log will output null data in all fields until a valid almanac is obtained.

Message ID: 226

Log Type: Synch

Field	Structure	Field Description	Symbol	Example
1	\$GPVTG	Log header		\$GPVTG
2	track true	Track made good, degrees True	x.x	24.168
3	T	True track indicator	T	T
4	track mag	Track made good, degrees Magnetic; Track mag = Track true + (MAGVAR correction) See the <i>MAGVAR</i> command, <i>Page 93</i> .	x.x	24.168
5	M	Magnetic track indicator	M	M
6	speed Kn	Speed over ground, knots	x.x	0.4220347
7	N	Nautical speed indicator (N = Knots)	N	N
8	speed Km	Speed, kilometers/hour	x.x	0.781608
9	K	Speed indicator (K = km/hr)	K	K
10	*xx	Checksum	*hh	*7A
11	[CR][LF]	Sentence terminator		[CR][LF]

Recommended Input:

log gpvtg ontime 1

Example:

\$GPVTG,235.083,T,235.083,M,0.003,N,0.006,K*4B

3.4.29 GPZDA UTC Time and Date NMEA

This log will output null data in all fields until a valid almanac is downloaded from a satellite. Any alternate almanac already in NVM will not be output.

Message ID: 227

Log Type: Synch

Field	Structure	Field Description	Symbol	Example
1	\$GPZDA	Log header		\$GPZDA
2	utc	UTC time	hhmmss.ss	220238.00
3	day	Day, 01 to 31	xx	15
4	month	Month, 01 to 12	xx	07
5	year	Year	xxxx	1992
6	null	Local zone description - not available	xx	, ,
7	null	Local zone minutes description - not available ^a	xx	, ,
8	*xx	Checksum	*hh	*6F
9	[CR][LF]	Sentence terminator		[CR][LF]

- a Local time zones are not supported by the OEM4 family receiver. Fields 6 and 7 will always be null.

Recommended Input:

```
log gpzda ontime 1
```

Example:

```
$GPZDA,184330.00,23,03,2004,,*6F
```

3.4.30 IONUTC Ionospheric and UTC Data

The Ionospheric Model parameters (ION) and the Universal Time Coordinated parameters (UTC) are provided.

Message ID: 8
Log Type: Asynch

Field #	Field type	Data Description	Format	Binary Bytes	Binary Offset
1	header	Log header		H	0
2	a0	Alpha parameter constant term	Double	8	H
3	a1	Alpha parameter 1st order term	Double	8	H+8
4	a2	Alpha parameter 2nd order term	Double	8	H+16
5	a3	Alpha parameter 3rd order term	Double	8	H+24
6	b0	Beta parameter constant term	Double	8	H+32
7	b1	Beta parameter 1st order term	Double	8	H+40
8	b2	Beta parameter 2nd order term	Double	8	H+48
9	b3	Beta parameter 3rd order term	Double	8	H+56
10	utc wn	UTC reference week number	Ulong	4	H+64
11	tot	Reference time of UTC parameters	Ulong	4	H+68
12	A0	UTC constant term of polynomial	Double	8	H+72
13	A1	UTC 1st order term of polynomial	Double	8	H+80
14	wn lsf	Future week number	Ulong	4	H+88
15	dn	Day number (the range is 1 to 7 where Sunday = 1 and Saturday = 7)	Ulong	4	H+92
16	deltat ls	Delta time due to leap seconds	Long	4	H+96
17	deltat lsf	Future delta time due to leap seconds	Long	4	H+100
18	Reserved		Ulong	4	H+104
19	xxxx	32-bit CRC (ASCII and Binary only)	Hex	4	H+108
20	[CR][LF]	Sentence terminator (ASCII only)	-	-	-

Recommended Input:

log ionutca onchanged

ASCII Example:

```
#IONUTCA, COM1, 0, 76.0, FINESTEERING, 1263, 240240.111, 00000000, ec21, 1522;
2.142041921615601e-08, 7.450580596923827e-09, -1.192092895507812e-07,
0.0000000000000000e+000, 1.2288000000000000e+05, 0.0000000000000000e+000,
-2.6214400000000000e+05, 1.9660800000000000e+05, 1263, 405504,
1.3969838619232178e-08, 3.641531521e-14, 1246, 5, 13, 13, 0*559e0e85
```

3.4.31 LBANDINFO L-Band Configuration Information

This log outputs configuration information for an L-Band service. In the case of using the free CDGPS service, no subscription is required and therefore the subscription fields will report an UNKNOWN subscription status. See also the examples on the next page.

-
- ☒ 1. In addition to a NovAtel receiver with L-Band capability, a subscription to the OmniSTAR, or use of the free CDGPS, service is required. Contact NovAtel for details. Contact information may be found on the back of this manual or you can refer to the *Customer Service* section in *Volume 1* of this manual set.
 - 2. The OMNIINFO log is still available to OmniSTAR users but will be made obsolete in a future firmware release. Please use the LBANDINFO log instead.
-

Message ID: 730
Log Type: Asynch

Field #	Field Type	Data Description	Format	Binary Bytes	Binary Offset
1	header	Log header		H	0
2	freq	Selected frequency for L-Band service (kHz)	Ulong	4	H
3	baud	Communication baud rate from L-Band satellite	Ulong	4	H+4
4	ID	L-Band signal service ID	Ushort	2	H+8
5	Reserved		Ushort	2	H+10
6	OSN	L-Band serial number	Ulong	4	H+12
7	vbs sub	L-Band VBS subscription type (see <i>Table 55 on Page 208</i>)	Enum	4	H+16
8	vbs exp week	GPS week number of L-Band VBS expiration date ^a	Ulong	4	H+20
9	vbs exp secs	Number of seconds into the GPS week of L-Band VBS expiration date ^a	Ulong	4	H+24
10	hp sub	OmniSTAR HP or XP subscription type (see <i>Table 55 on Page 208</i>)	Enum	4	H+28
11	hp exp week	GPS week number of OmniSTAR HP or XP expiration date ^a	Ulong	4	H+32
12	hp exp secs	Number of seconds into the GPS week of OmniSTAR HP or XP expiration date ^a	Ulong	4	H+36
13	hp sub mode	HP or XP subscription mode if the subscription is valid: 0 = HP 1 = XP	Ulong	4	H+40
14	xxxx	32-bit CRC (ASCII and Binary only)	Hex	4	H+44
15	[CR][LF]	Sentence terminator (ASCII only)	-	-	-

- a. If the subscription type is COUNTDOWN, see Field #7 above, the expiration week and expiration seconds into the GPS week will contain the amount of running time remaining in the subscription. If the subscription type is COUNTDOWNOVERRUN, the expiration week and expiration seconds into GPS week will count the amount of the overrun time.

Table 55: L-Band Subscription Type

Binary	ASCII	Description
0	EXPIRED	The L-Band subscription has expired or does not exist.
1	FIXEDTIME	The L-Band subscription will expire at a fixed date and time.
2	COUNTDOWN	The L-Band subscription will expire after the specified amount of running time.
3	COUNTDOWNOVERRUN	The COUNTDOWN subscription has expired but has entered a brief grace period. Resubscribe immediately.
16	UNKNOWN	Unknown subscription

Recommended Input:

```
log lbandinfoa ontime 1
```

ASCII Example 1 (OmniSTAR HP):

```
#LBANDINFOA, COM2, 0, 81.5, FINESTEERING, 1295, 152639.184, 00000240, c51d, 34461;
1547547, 4800, c685, 0, 762640, EXPIRED, 0, 0, FIXEDTIME, 1199, 259199, 0*8cc5e573
```

Abbreviated ASCII Example 2 (CDGPS):

```
LBANDINFO COM1 0 45.5 FINESTEERING 1297 498512.389 00000000 c51d 34486
1547547 4800 0 0 762640 UNKNOWN 0 0 UNKNOWN 0 0 0
```

3.4.32 LBANDSTAT L-Band Status Information

This log outputs status information for a standard L-Band, OmniSTAR XP or OmniSTAR HP (High Performance) service.

-
- ☒ 1. In addition to a NovAtel receiver with L-Band capability, a subscription to the OmniSTAR, or use of the free CDGPS, service is required. Contact NovAtel for details. Contact information may be found on the back of this manual or you can refer to the *Customer Service* section in *Volume 1* of this manual set.
 - 2. The OMNISTAT log is still available to OmniSTAR users but will be made obsolete in a future firmware release. Please use the LBANDSTAT log instead.
 - 3. Changes to the status fields of the LBANDSTAT log also apply to the obsolete OMNISTAT log.
-

Message ID: 731

Log Type: Asynch

Field #	Field Type	Data Description	Format	Binary Bytes	Binary Offset
1	header	Log header		H	0
2	freq	Measured frequency of L-Band signal (Hz)	Ulong	4	H
3	C/N ₀	Carrier to noise density ratio $C/N_0 = 10[\log_{10}(S/N_0)]$ (dB-Hz)	Float	4	H+4
4	locktime	Number of seconds of continuous tracking (no cycle slipping)	Float	4	H+8
5	Reserved		Float	4	H+12
6	tracking	Tracking status of L-Band signal (see <i>Table 56 on Page 210</i>)	Hex	2	H+16
7	VBS status	Status word for OmniSTAR VBS (see <i>Table 57 on Page 210</i>)	Hex	2	H+20
8	#bytes	Number of bytes fed to the standard process	Ulong	4	H+24
9	#good dgps	Number of standard updates	Ulong	4	H+28
10	#bad data	Number of missing standard updates	Ulong	4	H+32
11	Reserved	(the <i>hp status 1</i> field is obsolete and has been replaced by the longer OmniSTAR HP Status field. The shorter legacy status here is maintained for backward compatibility)	Hex	2	H+36
12	hp status 2	Additional status pertaining to the HP or XP process (see <i>Table 58 on Page 211</i>)	Hex	2	H+40
13	#bytes hp	Number of bytes fed to the HP or XP process	Ulong	4	H+44
14	hp status	Status from the HP or XP process (see <i>Table 59 on Page 211</i>)	Hex	2	H+48
15	Reserved		Hex	4	H+50
16	xxxx	32-bit CRC (ASCII and Binary only)	Hex	4	H+54
17	[CR][LF]	Sentence terminator (ASCII only)	-	-	-

Recommended Input:

log lbandstata ontime 1

ASCII Example:

```
#LBANDSTAT,COM1,0,73.5,FINESTEERING,1314,494510.000,00000000,c797,1846;
1551488896,43.19,62.3,0.00,0082,0000,7235,11,0,0000,0001,7762,04000000,0
*93F7d2af
```

Table 56: L-Band Signal Tracking Status

Nibble #	Bit #	Mask	Description	Range Value
N0	0	0x0001	Tracking State	0 = Searching for data 1 = Data found and verifying 2 = Producing data
	1	0x0002		
	2	0x0004	Reserved	
	3	0x0008		
N1	4	0x0010	Reserved	
	5	0x0020		
	6	0x0040	Bit Timing Lock	0 = Not Locked, 1 = Locked
	7	0x0080	Phase Lock	0 = Not Locked, 1 = Locked
N2	8	0x0100	DC Offset Unlocked	0 = Good, 1 = Warning
	9	0x0200	AGC Unlocked	0 = Good, 1 = Warning
	10	0x0400	Reserved	
	11	0x0800		
N3	12	0x1000	Reserved	
	13	0x2000		
	14	0x4000	Error	0 = Good, 1 = Error
	15	0x8000		

Table 57: OmniSTAR VBS Status Word

Nibble #	Bit #	Mask	Description	Bit = 0	Bit = 1
N0	0	0x0001	Subscription Expired ^a	False	True
	1	0x0002	Out of Region ^a	False	True
	2	0x0004	Wet Error ^a	False	True
	3	0x0008	Link Error ^a	False	True
N1	4	0x0010	No Remote Sites	False	True
	5	0x0020	No Almanac	False	True
	6	0x0040	No Position	False	True
	7	0x0080	No Time	False	True
N2	8	0x0100	Reserved		
	9	0x0200			
	10	0x0400			
	11	0x0800			
N3	12	0x1000	Reserved		
	13	0x2000			
	14	0x4000			
	15	0x8000			

- a. Contact OmniSTAR for subscription support. All other status values will be updated by collecting OmniSTAR data for 20-35 minutes.

Table 58: OmniSTAR HP Additional Status Word

Nibble #	Bit #	Mask	Description	Bit = 0	Bit = 1
N0	0	0x0001	Solution not fully converged	False	True
	1	0x0002	Reserved		
	2	0x0004			
	3	0x0008			
N1	4	0x0010	HP not authorized	Authorized	Unauthorized
	5	0x0020	XP not authorized	Authorized	Unauthorized
	6	0x0040	Reserved		
	7	0x0080			
N2	8	0x0100		Reserved	
	9	0x0200			
	10	0x0400			
	11	0x0800			
N3	12	0x1000	Reserved		
	13	0x2000			
	14	0x4000			
	15	0x8000			

Table 59: OmniSTAR HP Status Word

Nibble #	Bit #	Mask	Description	Bit = 0	Bit = 1
N0	0	0x00000001	Subscription Expired ^a	False	True
	1	0x00000002	Out of Region ^a	False	True
	2	0x00000004	Wet Error ^a	False	True
	3	0x00000008	Link Error ^a	False	True
N1	4	0x00000010	No Measurements	False	True
	5	0x00000020	No Ephemeris	False	True
	6	0x00000040	No Initial Position	False	True
	7	0x00000080	No Time Set	False	True
N2	8	0x00000100	Velocity Error	False	True
	9	0x00000200	No Reference Stations	False	True
	10	0x00000400	No Mapping Message	False	True
	11	Reserved			
N3-N5	12-23	Reserved			
N6	24-25				
	26	0x04000000	Static Initialization Mode	False	True
	27	Reserved			
N7	28-30	Reserved			
	31	0x80000000	Updating Data	False	True

- a. Contact OmniSTAR for subscription support. All other status values will be updated by collecting the OmniSTAR data for 20-35 minutes.

3.4.33 LOGLIST List of System Logs

Outputs a list of log entries in the system. The following table is of the binary output while *Table 60* on *Page 213* shows the ASCII output. See also the RXCONFIG log on *Page 297* for a list of current command settings.

Message ID: 5
Log Type: Polled

Field #	Field type	Data Description	Format	Binary Bytes	Binary Offset
1	header	Log header		H	0
2	#logs	Number of messages to follow, maximum = 20	Long	4	H
3	port	Output port, see <i>Table 5, Detailed Serial Port Identifiers</i> on <i>Page 18</i>	Enum	4	H+4
4	message	Message ID of log	Ushort	2	H+8
5	message type	Bits 0-4 = Reserved Bits 5-6 = Format 00 = Binary 01 = ASCII 10 = Abbreviated ASCII, NMEA 11 = Reserved Bit 7 = Response Bit (see <i>Section 1.2, Responses</i> on <i>Page 20</i>) 0 = Original Message 1 = Response Message	Char	1	H+10
6	reserved		Char	3 ^a	H+11
7	trigger	0 = ONNEW 1 = ONCHANGED 2 = ONTIME 3 = ONNEXT 4 = ONCE 5 = ONMARK	Enum	4	H+14
8	period	Log period for ONTIME	Double	8	H+18
9	offset	Offset for period (ONTIME trigger)	Double	8	H+26
10	hold	0 = NOHOLD 1 = HOLD	Enum	4	H+34
11...	Next log offset = H + 4 + (#logs x 34)				
variable	xxxx	32-bit CRC	Hex	4	H+4+ (#logs x 34)

a. In the binary log case an additional 2 bytes of padding are added to maintain 4 byte alignment

Table 60: LOGLIST ASCII Format

Field #	Field type	Data Description	Format
1	header	Log header	
2	#port	Number of messages to follow, maximum = 20	Long
3	port	Output port, see <i>Table 5, Detailed Serial Port Identifiers on Page 18</i>	Enum
4	message	Message name of log with no suffix for abbreviated ascii, an A suffix for ascii and a B suffix for binary.	Char []
5	trigger	ONNEW ONCHANGED ONTIME ONNEXT ONCE ONMARK	Enum
6	period	Log period for ONTIME	Double
7	offset	Offset for period (ONTIME trigger)	Double
8	hold	NOHOLD HOLD	Enum
9...	Next port		
variable	xxxx	32-bit CRC	Hex
variable	[CR][LF]	Sentence terminator	-

Recommended Input:

```
log loglista once
```

ASCII Example:

```
#LOGLISTA, COM1, 0, 79.5, FINESTEERING, 1263, 241051.827, 00000000, c00c, 1522;
8,
COM1, RXSTATUSEVENTA, ONNEW, 0.000000, 0.000000, HOLD,
COM2, RXSTATUSEVENTA, ONNEW, 0.000000, 0.000000, HOLD,
COM3, RXSTATUSEVENTA, ONNEW, 0.000000, 0.000000, HOLD,
USB1, RXSTATUSEVENTA, ONNEW, 0.000000, 0.000000, HOLD,
USB2, RXSTATUSEVENTA, ONNEW, 0.000000, 0.000000, HOLD,
USB3, RXSTATUSEVENTA, ONNEW, 0.000000, 0.000000, HOLD,
COM1, BESTPOSA, ONTIME, 10.000000, 0.000000, NOHOLD,
COM1, LOGLISTA, ONCE, 0.000000, 0.000000, NOHOLD*4a4d995d
```

3.4.34 MARKPOS, MARK2POS Position at Time of Mark Input Event

This log contains the estimated position of the antenna when a pulse is detected at a mark input. MARKPOS is a result of a pulse on the MK1I input and MARK2POS is generated when a pulse occurs on a MK2I input. Refer to the *Technical Specifications* appendix in *Volume 1* of this manual set for mark input pulse specifications and the location of the mark input pins.

The position at the mark input pulse is extrapolated using the last valid position and velocities. The latched time of mark impulse is in GPS weeks and seconds into the week. The resolution of the latched time is 49 ns. See also the notes on MARKPOS in the MARKTIME log on *Page 216*.

Message ID: 181 (MARKPOS) and 615 (MARK2POS)

Log Type: Asynch

Field #	Field type	Data Description	Format	Binary Bytes	Binary Offset
1	header	Log header		H	0
2	sol status	Solution status (see <i>Table 48, Solution Status on Page 163</i>)	Enum	4	H
3	pos type	Position type (see <i>Table 47, Position or Velocity Type on Page 162</i>)	Enum	4	H+4
4	lat	Latitude	Double	8	H+8
5	lon	Longitude	Double	8	H+16
6	hgt	Height above mean sea level	Double	8	H+24
7	undulation	Undulation - the relationship between the geoid and the WGS84 ellipsoid (m) ^a	Float	4	H+32
8	datum id#	Datum ID number (see <i>Chapter 2, Table 20, Datum Transformation Parameters on Page 65</i>)	Enum	4	H+36
9	lat σ	Latitude standard deviation	Float	4	H+40
10	lon σ	Longitude standard deviation	Float	4	H+44
11	hgt σ	Height standard deviation	Float	4	H+48
12	stn id	Base station ID	Char[4]	4	H+52
13	diff_age	Differential age in seconds	Float	4	H+56
14	sol_age	Solution age in seconds	Float	4	H+60
15	#obs	Number of observations tracked	Uchar	1	H+64
16	#GPSL1	Number of GPS L1 ranges used in computation	Uchar	1	H+65
17	#L1	Number of GPS L1 ranges above the RTK mask angle	Uchar	1	H+66
18	#L2	Number of GPS L2 ranges above the RTK mask angle	Uchar	1	H+67
19	Reserved		Uchar	1	H+68
20			Uchar	1	H+69
21			Uchar	1	H+70
22			Uchar	1	H+71
23	xxxx	32-bit CRC (ASCII and Binary only)	Hex	4	H+72
24	[CR][LF]	Sentence terminator (ASCII only)	-	-	-

- a. When using a datum other than WGS84, the undulation value also includes the vertical shift due to differences between the datum in use and WGS84

Recommended Input:

log markposa onnew

Use the ONNEW trigger with the MARKTIME or MARKPOS logs.

Example:

```
#MARKPOSA, COM1, 0, 63.0, COARSE, 1027, 322788.595, 00000000, 6221, 0;  
SOL_COMPUTED, WIDELANE, 51.11227014, -114.03907552, 1003.799, -16.199, 61,  
7.793, 3.223, 34.509, "", 0.0, 60.000, 8, 4, 4, 4, 0, 0, 0, 0, 1*99999999
```

3.4.35 MARKTIME, MARK2TIME Time of Mark Input Event

This log contains the time of the leading edge of the detected mark input pulse. MARKTIME gives the time when a pulse occurs on the MK1I input and MARK2TIME is generated when a pulse occurs on a MK2I input. Refer to the *Technical Specifications* appendix in *Volume 1* of this manual set for mark input pulse specifications and the location of the mark input pins. The resolution of this measurement is 49ns.

Message ID: 231 (MARKTIME) and 616 (MARK2TIME)

Log Type: Asynch

Field #	Field type	Data Description	Format	Binary Bytes	Binary Offset
1	header	Log header		H	0
2	week	GPS week number	Long	4	H
3	seconds	Seconds into the week as measured from the receiver clock, coincident with the time of electrical closure on the Mark Input port.	Double	8	H+4
4	offset	Receiver clock offset, in seconds. A positive offset implies that the receiver clock is ahead of GPS Time. To derive GPS time, use the following formula: GPS time = receiver time - (offset)	Double	8	H+12
5	offset std	Standard deviation of receiver clock offset (s)	Double	8	H+20
6	utc offset	This field represents the offset of GPS time from UTC time, computed using almanac parameters. UTC time is GPS time plus the current UTC offset plus the receiver clock offset. UTC time = GPS time + offset + UTC offset ^a	Double	8	H+28
7	status	Clock model status, see <i>Table 49, Clock Model Status on Page 173</i>	Enum	4	H+36
8	xxxx	32-bit CRC (ASCII and Binary only)	Hex	4	H+40
9	[CR][LF]	Sentence terminator (ASCII only)	-	-	-

- a. 0 indicates that UTC time is unknown because there is no almanac available in order to acquire the UTC offset.

Recommended Input:

log marktimea onnew

Example:

```
#MARKTIME, COM1, 0, 63.0, COARSE, 1027, 322788.595, 00000000, 6221, 0;
653, 338214.773382376, 0.000504070, 0.000000013, -8.000000000, 0*99999999
```

-
- 1. Use the ONNEW trigger with this or the MARKPOS logs.
 - 2. Only the MARKPOS logs, the MARKTIME logs, and 'polled' log types are generated 'on the fly' at the exact time of the mark. Synchronous and asynchronous logs output the most recently available data.
-

3.4.36 MATCHEDPOS Matched RTK Position RTK

This log represents positions that have been computed from time matched base and rover observations. There is no base station extrapolation error on these positions because they are based on buffered measurements; they lag real time by some amount depending on the latency of the data link. If the rover receiver has not been enabled to accept RTK differential data, or is not actually receiving data leading to a valid solution, this will be reflected by the code shown in field #2 (solution status) and #3 (position type).

This log provides the best accuracy in static operation. For lower latency in kinematic operation, see the RTKPOS or BESTPOS logs.

The data in the logs will change only when a base observation (RTCM, RTCMV3, RTCA, or CMR) changes.

A good message trigger for this log is "ONCHANGED". Then, only positions related to unique base station messages will be produced, and the existence of this log will indicate a successful link to the base station.

-
- ☒ Asynchronous logs, such as MATCHEDPOS, should only be logged ONCHANGED. Otherwise, the most current data is not output when it is available. This is especially true of the ONTIME trigger, which may cause inaccurate time tags to result.
-

Message ID: 96

Log Type: Asynch

Field #	Field type	Data Description	Format	Binary Bytes	Binary Offset
1	header	Log header		H	0
2	sol status	Solution status (see <i>Table 48, Solution Status on Page 163</i>)	Enum	4	H
3	pos type	Position type (see <i>Table 47, Position or Velocity Type on Page 162</i>)	Enum	4	H+4
4	lat	Latitude	Double	8	H+8
5	lon	Longitude	Double	8	H+16
6	hgt	Height above mean sea level	Double	8	H+24
7	undulation	Undulation - the relationship between the geoid and the WGS84 ellipsoid (m) ^a	Float	4	H+32
8	datum id#	Datum ID number (see <i>Chapter 2, Table 20, Datum Transformation Parameters on Page 65</i>)	Enum	4	H+36
9	lat σ	Latitude standard deviation	Float	4	H+40
10	lon σ	Longitude standard deviation	Float	4	H+44
11	hgt σ	Height standard deviation	Float	4	H+48
12	stn id	Base station ID	Char[4]	4	H+52

Continued on Page 218

Field #	Field type	Data Description	Format	Binary Bytes	Binary Offset
13	Reserved		Float	4	H+56
14			Float	4	H+60
15	#obs	Number of observations tracked	Uchar	1	H+64
16	#GPSL1	Number of GPS L1 ranges used in computation	Uchar	1	H+65
17	#L1	Number of GPS L1 ranges above the RTK mask angle	Uchar	1	H+66
18	#L2	Number of GPS L2 ranges above the RTK mask angle	Uchar	1	H+67
19	Reserved		Uchar	1	H+68
20			Uchar	1	H+69
21			Uchar	1	H+70
22			Uchar	1	H+71
23	xxxx	32-bit CRC (ASCII and Binary only)	Hex	4	H+72
24	[CR][LF]	Sentence terminator (ASCII only)	-	-	-

- a. When using a datum other than WGS84, the undulation value also includes the vertical shift due to differences between the datum in use and WGS84

Recommended Input:

log matchedposa onchanged

ASCII Example:

```
#MATCHEDPOSA, COM1, 0, 79.5, FINESTEERING, 1263, 241396.000, 00000000, b743, 1522;
SOL_COMPUTED, NARROW_INT, 51.11633809849, -114.03839553770, 1048.2376, -16.2711,
WGS84, 0.0065, 0.0063, 0.0117, "AAAA", 0.000, 0.000, 9, 8, 8, 0, 0, 0, 0*93bd6cd0
```

3.4.37 MATCHEDXYZ Matched RTK Cartesian Position RTK

This log contains the receiver's matched position in ECEF coordinates. It represents positions that have been computed from time matched base and rover observations. There is no base station extrapolation error on these positions because they are based on buffered measurements; they lag real time by some amount depending on the latency of the data link. If the rover receiver has not been enabled to accept RTK differential data, or is not actually receiving data leading to a valid solution, this will be reflected by the code shown in field #2 (solution status) and #3 (position type). See *Figure 8, Page 170* for a definition of the ECEF coordinates.

This log provides the best accuracy in static operation. For lower latency in kinematic operation, see the BESTXYZ or RTKXYZ logs on *Pages 168 and 295* respectively. The data in the logs will change only when a base observation (RTCM, RTCMV3, RTCA, or CMR) changes.

A good message trigger for this log is "ONCHANGED". Then, only positions related to unique base station messages will be produced, and the existence of this log will indicate a successful link to the base station.

The time stamp in the header is the time of the matched observations that the computed position is based on, not the current time.

Message ID: 242
Log Type: Asynch

Field #	Field type	Data Description	Format	Binary Bytes	Binary Offset
1	header	Log header		H	0
2	P-sol status	Solution status, see <i>Table 48, Solution Status on Page 163</i>	Enum	4	H
3	pos type	Position type, see <i>Table 47, Position or Velocity Type on Page 162</i>	Enum	4	H+4
4	P-X	Position X-coordinate (m)	Double	8	H+8
5	P-Y	Position Y-coordinate (m)	Double	8	H+16
6	P-Z	Position Z-coordinate (m)	Double	8	H+24
7	P-X σ	Standard deviation of P-X (m)	Float	4	H+32
8	P-Y σ	Standard deviation of P-Y (m)	Float	4	H+36
9	P-Z σ	Standard deviation of P-Z (m)	Float	4	H+40
18	stn ID	Base station ID	Char[4]	4	H+44
22	#obs	Number of observations tracked	Uchar	1	H+48
23	#GPSL1	Number of GPS L1 ranges used in computation	Uchar	1	H+49
24	#L1	Number of GPS L1 ranges above the RTK mask angle	Uchar	1	H+50
25	#L2	Number of GPS L2 ranges above the RTK mask angle	Uchar	1	H+51
26	Reserved		Char	1	H+52
27			Char	1	H+53
28			Char	1	H+54
29			Char	1	H+55
30	xxxx	32-bit CRC (ASCII and Binary only)	Hex	4	H+56
31	[CR][LF]	Sentence terminator (ASCII only)	-	-	-

Recommended Input:

log matchedxyza onchanged

- ☒ Asynchronous logs, such as MATCHEDXYZ, should only be logged ONCHANGED. Otherwise, the most current data is not output when it is available. This is especially true of the ONTIME trigger, which may cause inaccurate time tags to result.
-

ASCII Example:

```
#MATCHEDXYZA, COM1, 0, 74.5, FINESTEERING, 1263, 241448.000, 00000000, f98b, 1522;  
SOL_COMPUTED, NARROW_INT, -1634532.4437, -3664608.9032, 4942482.7181,  
0.0070, 0.0062, 0.0117, "AAAA", 9, 8, 8, 8, 0, 0, 0, 0*e215b592
```

3.4.38 NAVIGATE User Navigation Data

This log reports the status of the waypoint navigation progress. It is used in conjunction with the SETNAV command, see *Page 121*.

See *Figure , below*, for an illustration of navigation parameters.

The SETNAV command must be enabled before valid data will be reported from this log.

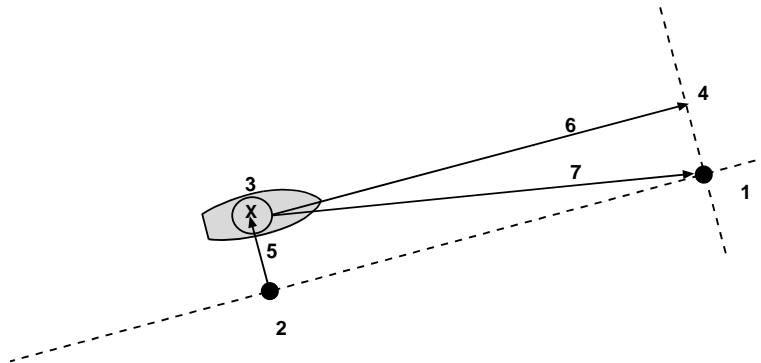

Reference	Description
1	TO lat-lon
2	X-Track perpendicular reference point
3	Current GPS position
4	A-Track perpendicular reference point
5	X-Track (cross track)
6	A-Track (along track)
7	Distance and bearing from 3 to 1

Figure 9: Navigation Parameters

Table 61: Navigation Data Type

Navigation Data Type		Description
Binary	ASCII	
0	GOOD	Navigation is good
1	NOVELOCITY	Navigation has no velocity
2	BADNAV	Navigation calculation failed for an unknown reason
3	FROM_TO_SAME	“From” is too close to “To” for computation
4	TOO_CLOSE_TO_TO	Position is too close to “To” for computation
5	ANTIPODAL_WAYPTS	Waypoints are antipodal on surface

Message ID: 161
Log Type: Synch

Field #	Field Type	Data Description	Format	Binary Bytes	Binary Offset
1	header	Log header		H	0
2	sol status	Solution status, see <i>Table 48, Solution Status on Page 163</i>	Enum	4	H
3	pos type	Position type, see <i>Table 47, Position or Velocity Type on Page 162</i>	Enum	4	H+4
4	vel type	Velocity type, see <i>Table 47, Position or Velocity Type on Page 162</i>	Enum	4	H+8
5	nav type	Navigation data type (see <i>Table 61, Navigation Data Type on Page 221</i>).	Enum	4	H+12
6	distance	Straight line horizontal distance from current position to the destination waypoint, in meters (see <i>Figure on Page 221</i>). This value is positive when approaching the waypoint and becomes negative on passing the waypoint.	Double	8	H+16
7	bearing	Direction from the current position to the destination waypoint in degrees with respect to True North (or Magnetic if corrected for magnetic variation by MAGVAR command)	Double	8	H+24
8	along track	Horizontal track distance from the current position to the closest point on the waypoint arrival perpendicular; expressed in meters. This value is positive when approaching the waypoint and becomes negative on passing the waypoint.	Double	8	H+32
9	xtrack	The horizontal distance (perpendicular track-error) from the vessel's present position to the closest point on the great circle line that joins the FROM and TO waypoints. If a "track offset" has been entered in the SETNAV command, xtrack will be the perpendicular error from the "offset track". Xtrack is expressed in meters. Positive values indicate the current position is right of the Track, while negative offset values indicate left.	Double	8	H+40
10	eta week	Estimated GPS week number at time of arrival at the "TO" waypoint along track arrival perpendicular based on current position and speed, in units of GPS weeks. If the receiving antenna is moving at a speed of less than 0.1 m/sec in the direction of the destination, the value in this field will be "9999".	Ulong	4	H+48
11	eta secs	Estimated GPS seconds into week at time of arrival at destination waypoint along track arrival perpendicular, based on current position and speed, in units of GPS seconds into the week. If the receiving antenna is moving at a speed of less than 0.1 m/sec in the direction of the destination, the value in this field will be "0.000".	Double	8	H+52
12	xxxx	32-bit CRC (ASCII and Binary only)	Hex	4	H+60
13	[CR][LF]	Sentence terminator (ASCII only)	-	-	-

Recommended Input:

```
log navigatea ontime 1
```

ASCII Example:

```
#NAVIGATEA, COM1, 0, 75.0, FINESTEERING, 1263, 241580.000, 00000000, aece, 1522;
SOL_COMPUTED, NARROW_INT, SOL_COMPUTED, NOVELOCITY, 5745.2403, 168.674455,
5745.2403, -125.2312, 9999, 0.000*4bef7c5d
```

3.4.39 NMEA Standard Logs

See the chapter on *Message Formats* in *Volume 1* of this manual set for more detail on the structure of NMEA logs. The details for the following NMEA logs are listed alphabetically in this chapter.

GPALM	ALMANAC DATA
GPGGA	GLOBAL POSITION SYSTEM FIX DATA AND UNDULATION
GPGGALONG	GPS FIX DATA, EXTRA PRECISION AND UNDULATION
GPGGARTK	GPS FIX DATA
GPGLL	GEOGRAPHIC POSITION
GPGRS	GPS RANGE RESIDUALS FOR EACH SATELLITE
GPGSA	GPS DOP AN ACTIVE SATELLITES
GPGST	PSEUDORANGE MEASUREMENT NOISE STATISTICS
GPGSV	GPS SATELLITES IN VIEW
GPRMB	NAVIGATION INFORMATION
GPRMC	GPS SPECIFIC INFORMATION
GPVTG	TRACK MADE GOOD AND GROUND SPEED
GPZDA	UTC TIME AND DATE

3.4.40 OMNIHPPOS OmniSTAR HP Position

Outputs L-Band Extra Performance (XP) or High Performance (HP) position information.

- In addition to a NovAtel receiver with L-Band capability, a subscription to the OmniSTAR service is required. Contact NovAtel for details. Contact information may be found on the back of this manual or you can refer to the *Customer Service* section in *Volume 1* of this manual set.

Message ID: 495

Log Type: Synch

Field #	Field type	Data Description	Format	Binary Bytes	Binary Offset
1	header	Log header		H	0
2	sol status	Solution status, see <i>Table 48, Solution Status on Page 163</i>	Enum	4	H
3	pos type	Position type, see <i>Table 47, Position or Velocity Type on Page 162</i>	Enum	4	H+4
4	lat	Latitude	Double	8	H+8
5	lon	Longitude	Double	8	H+16
6	hgt	Height above mean sea level	Double	8	H+24
7	undulation	Undulation - the relationship between the geoid and the WGS84 ellipsoid (m) ^a	Float	4	H+32
8	datum id#	Datum ID number (see <i>Chapter 2, Table 20, Datum Transformation Parameters on Page 65</i>)	Enum	4	H+36
9	lat σ	Latitude standard deviation	Float	4	H+40
10	lon σ	Longitude standard deviation	Float	4	H+44
11	hgt σ	Height standard deviation	Float	4	H+48
12	stn id	Base station ID	Char[4]	4	H+52
13	diff_age	Differential age in seconds	Float	4	H+56
14	sol_age	Solution age in seconds	Float	4	H+60
15	#obs	Number of observations tracked	Uchar	1	H+64
16	#GPSL1	Number of GPS L1 ranges used in computation	Uchar	1	H+65
17	#L1	Number of GPS L1 ranges above the RTK mask angle	Uchar	1	H+66
18	#L2	Number of GPS L2 ranges above the RTK mask angle	Uchar	1	H+67
19	Reserved		Uchar	1	H+68
20			Uchar	1	H+69
21			Uchar	1	H+70
22			Uchar	1	H+71
23	xxxx	32-bit CRC (ASCII and Binary only)	Hex	4	H+72
24	[CR][LF]	Sentence terminator (ASCII only)	-	-	-

- a. When using a datum other than WGS84, the undulation value also includes the vertical shift due to differences between the datum in use and WGS84

Recommended Input:

log omnihpposa ontime 1

ASCII Example:

```
#OMNIHPPOSA,COM1,0,72.0,FINESTEERING,1161,321910.000,00000000,ad26,683;  
SOL_COMPUTED,OMNISTAR_HP,51.11635244839,-114.03819232612,1064.1015,-16.2713,  
WGS84,0.1371,0.1390,0.2741,"",5.000,0.000,7,6,6,6,0,0,0,0*66c318fb
```

3.4.41 **PASSCOM, PASSXCOM, PASSAUX, PASSUSB Redirect Data**

The pass-through logging feature enables the receiver to redirect any ASCII or binary data that is input at a specified port to any specified receiver port. Data can be passed through a disabled port, see the *INTERFACEMODE* command on *Page 87*, and be output from an alternative port using the pass-through logs. It also allows the receiver to perform bi-directional communications with other devices such as a modem, terminal or another receiver.

There are several pass-through logs. PASSCOM1, PASSCOM2, PASSCOM3, PASSXCOM1, PASSXCOM2 and PASSAUX allow for redirection of data that is arriving at COM1, COM2, COM3, virtual COM1, virtual COM2 or AUX, respectively. The AUX port is available on OEM4-G2-based receivers (hardware Rev. 3 and higher) and DL-4 products. PASSUSB1, PASSUSB2, PASSUSB3 are only available on receivers that support USB and can be used to redirect data from USB1, USB2, or USB3.

If the data being injected is ASCII, then the data will be grouped together with the following rules:

- blocks of 80 characters
- any block of characters ending in a <CR>
- any block of characters ending in a <LF>
- any block remaining in the receiver code when a time-out occurs (100 ms)

If the data being injected is binary, then the data will be grouped as follows:

- blocks of 80 bytes
- any block remaining in the receiver code when a time-out occurs (100 ms)

If a binary value is encountered in an ASCII output, then the byte is output as a hexadecimal byte preceded by a back slash and an x. For example 0x0a is output as \x0a. An actual '\ ' in the data is output as '\\'. The output counts as one pass-through byte although it is four characters.

For more information on pass-through logging, please see *Volume 1* of this manual set.

PASSCOM1 Message ID:233

PASSCOM2 Message ID:234

PASSCOM3 Message ID:235

PASSXCOM1 Message ID: 405

PASSXCOM2 Message ID: 406

PASSUSB1 Message ID: 607

PASSUSB2 Message ID: 608

PASSUSB3 Message ID: 609

PASSAUX Message ID: 690

Log Type: Asynch

Field #	Field type	Data Description	Format	Binary Bytes	Binary Offset
1	header	Log header		H	0
2	#bytes	Number of bytes to follow	Ulong	4	H
3	data	Message data	Char [80]	80	H+4
4...	Next byte offset = H + 4 + (#bytes x 80)				
variable	xxxx	32-bit CRC (ASCII and Binary only)	Hex	4	H+8+(#bytes x 80)
variable	[CR][LF]	Sentence terminator (ASCII only)	-	-	-

Recommended Input:

log passcom1a onchanged

-
- Asynchronous logs should only be logged ONCHANGED. Otherwise, the most current data is not output when it is available. This is especially true of the ONTIME trigger, which may cause inaccurate time tags to result.
-

ASCII Example 1:

```
LOG COM1 PASSCOM2A ONNEW
#PASSCOM2A,COM1,0,59.5,COARSESTEERING,1323,144532.877,004c0000,2b46,1874;22,
this is an example of *58de7722
#PASSCOM2A,COM1,0,59.5,COARSESTEERING,1323,144534.930,00440000,2b46,1874;7,pa
sscom*dc595769
#PASSCOM2A,COM1,0,60.0,COARSESTEERING,1323,144540.127,00440000,2b46,1874;32,2
a data input on the com2 port\x0d\x0a*92de38aa
```

In *Example 1*, the input string on COM2 was:

"this is an example of passcom2a data input on the com2 port[CR][LF]"

ASCII Example 2:

```
#PASSCOM2A,COM1,0,62.5,FINESTEERING,1263,242040.838,00000000,2b46,1522;
9,\x1e\xfb~\xd6\xfe\x17\x02\x17\xe2*bef61205
```

In the example, note that '~' is a printable character.

3.4.42 PORTSTATS Port Statistics

This log conveys various status parameters of the receiver's COM ports and, if supported, USB ports. The receiver maintains a running count of a variety of status indicators of the data link. This log outputs a report of those indicators.

Parity and framing errors will occur for COM ports if poor transmission lines are encountered or if there is an incompatibility in the data protocol. If errors occur, you may need to confirm the bit rate, number of data bits, number of stop bits and parity of both the transmit and receiving ends. Characters may be dropped when the CPU is overloaded.

Message ID: 72

Log Type: Polled

Field #	Field type	Data Description	Format	Binary Bytes	Binary Offset
1	header	Log header		H	0
2	#port	Number of ports with information to follow	Long	4	H
3	port	Serial port identifier, see <i>Table 15, COM Serial Port Identifiers on Page 60</i>	Enum	4	H+4
4	rx chars	Total number of characters received through this port	Ulong	4	H+8
5	tx chars	Total number of characters transmitted through this port	Ulong	4	H+12
6	acc rx chars	Total number of accepted characters received through this port	Ulong	4	H+16
7	dropped chars	Number of software overruns	Ulong	4	H+20
8	interrupts	Number of interrupts on this port	Ulong	4	H+24
9	breaks	Number of breaks (This field does not apply for a USB port and will always be set to 0 for USB.)	Ulong	4	H+28
10	par err	Number of parity errors (This field does not apply for a USB port and will always be set to 0 for USB.)	Ulong	4	H+32
11	fram err	Number of framing errors (This field does not apply for a USB port and will always be set to 0 for USB.)	Ulong	4	H+36
12	overruns	Number of hardware overruns	Ulong	4	H+40
13	Next port offset = H + 4 + (#port x 40)				
14	xxxx	32-bit CRC (ASCII and Binary only)	Hex	4	H+4+ (#port x 40)
15	[CR][LF]	Sentence terminator (ASCII only)	-	-	-

Recommended Input:

```
log portstatsa once
```

ASCII example:

```
#PORTSTATSA,COM1,0,73.5,FINESTEERING,1263,242178.588,00000000,a872,1522;  
6,  
COM1,2329,83352,2325,0,11521,4,0,0,0,  
COM2,576474,557,576474,0,74851,0,0,0,0,  
COM3,0,0,0,0,7,0,0,0,0,  
USB1,0,0,0,0,0,0,0,0,0,  
USB2,0,0,0,0,0,0,0,0,0,  
USB3,0,0,0,0,0,0,0,0,0*b7333ec1
```

3.4.43 PSRDOP Pseudorange DOP

The dilution of precision data is calculated using the geometry of only those satellites that are currently being tracked and used in the position solution by the receiver. This log is updated once every 60 seconds or whenever a change in the satellite constellation occurs. Therefore, the total number of data fields output by the log is variable and depends on the number of SVs that are being tracked. Twelve is the maximum number of SV PRNs contained in the list.

-
- ☒ 1. If a satellite is locked out using the LOCKOUT command, it will still be shown in the PRN list, but it will be significantly de-weighted in the DOP calculation
 - 2. The vertical dilution of precision can be calculated by: $vdop = \sqrt{pdop^2 - hdop^2}$
-

Message ID: 174
Log Type: Asynch

Field #	Field type	Data Description	Format	Binary Bytes	Binary Offset
1	header	Log header		H	0
2	gdop	Geometric dilution of precision - assumes 3-D position and receiver clock offset (all 4 parameters) are unknown.	Float	4	H
3	pdop	Position dilution of precision - assumes 3-D position is unknown and receiver clock offset is known.	Float	4	H+4
4	hdop	Horizontal dilution of precision.	Float	4	H+8
5	htdop	Horizontal position and time dilution of precision.	Float	4	H+12
6	tdop	Time dilution of precision - assumes 3-D position is known and only the receiver clock offset is unknown.	Float	4	H+16
7	cutoff	Elevation cut-off angle.	Float	4	H+20
8	#PRN	Number of satellites PRNs to follow.	Long	4	H+24
9	PRN	PRNof SV PRN tracking, null field until position solution available.	Ulong	4	H+28
10...	Next PRN offset = H + 28 + (#prn x 4)				
variable	xxxx	32-bit CRC (ASCII and Binary only)	Hex	4	H+28+ (#prn x 4)
variable	[CR][LF]	Sentence terminator (ASCII only)	-	-	-

Recommended Input:

log psrdopa onchanged

ASCII Example:

```
#PSRDOPA,COM1,0,73.0,FINESTEERING,1263,245640.500,00000000,768f,1522;
1.9216,1.7574,0.8475,1.1500,0.7774,5.0,9,29,10,16,21,24,26,18,17,30*7f6215c3
```

3.4.44 PSRPOS Pseudorange Position

This log contains the pseudorange position computed by the receiver, along with three status flags. In addition, it reports other status indicators, including differential age, which is useful in predicting anomalous behavior brought about by outages in differential corrections.

Message ID: 47
Log Type: Synch

Field #	Field type	Data Description	Format	Binary Bytes	Binary Offset
1	header	Log header		H	0
2	sol status	Solution status (see Table 48 on Page 163)	Enum	4	H
3	pos type	Position type (see Table 47 on Page 162)	Enum	4	H+4
4	lat	Latitude	Double	8	H+8
5	lon	Longitude	Double	8	H+16
6	hgt	Height above mean sea level	Double	8	H+24
7	undulation	Undulation - the relationship between the geoid and the WGS84 ellipsoid (m) ^a	Float	4	H+32
8	datum id#	Datum ID number (see Table 20, Datum Transformation Parameters on Page 65)	Enum	4	H+36
9	lat σ	Latitude standard deviation	Float	4	H+40
10	lon σ	Longitude standard deviation	Float	4	H+44
11	hgt σ	Height standard deviation	Float	4	H+48
12	stn id	Base station ID	Char[4]	4	H+52
13	diff_age	Differential age in seconds	Float	4	H+56
14	sol_age	Solution age in seconds	Float	4	H+60
15	#obs	Number of observations tracked	Uchar	1	H+64
16	#GPSL1	Number of GPS L1 ranges used in computation	Uchar	1	H+65
17	Reserved		Uchar	1	H+66
18			Uchar	1	H+67
19			Uchar	1	H+68
20			Uchar	1	H+69
21			Uchar	1	H+70
22			Uchar	1	H+71
23	xxxx	32-bit CRC (ASCII and Binary only)	Hex	4	H+72
24	[CR][LF]	Sentence terminator (ASCII only)	-	-	-

- a. When using a datum other than WGS84, the undulation value also includes the vertical shift due to differences between the datum in use and WGS84

Recommended Input:

log psrposa ontime 1

ASCII Example:

```
#PSRPOSA, COM1, 0, 70.0, FINESTEERING, 1263, 245720.000, 00000000, 2174, 1522;
SOL_COMPUTED, PSRDIFF, 51.11634011613, -114.03839917897, 1047.3624,
-16.2711, WGS84, 0.9056, 0.6452, 1.8299, "AAAA", 10.000, 0.000, 9, 9,
0, 0, 0, 0, 0, 0*59c99a48
```

3.4.45 PSRVEL Pseudorange Velocity

In the PSRVEL log the actual speed and direction of the receiver antenna over ground is provided. The velocity measurements sometimes have a latency associated with them. The time of validity is the time tag in the log minus the latency value. See also the table footnote for velocity logs on *Page 142*.

The velocity status indicates varying degrees of velocity quality. To ensure healthy velocity, the position sol-status must also be checked. If the sol-status is non-zero, the velocity will likely be invalid. It should be noted that the receiver does not determine the direction a vessel, craft, or vehicle is pointed (heading), but rather the direction of the motion of the GPS antenna relative to the ground.

The velocity is computed using Doppler values typically derived from differences in consecutive carrier phase measurements. As such, it is an average velocity based on the average change in pseudorange over the time interval and not an instantaneous velocity at the PSRVEL time tag. The velocity latency to be subtracted from the time tag will normally be 1/2 the time between filter updates. Under default operation, the position filter is updated at a rate of 2 Hz. This translates into a velocity latency of 0.25 second. The latency can be reduced by increasing the update rate of the filter by requesting the BESTVEL, PSRVEL, BESTPOS or PSRPOS messages at a rate higher than 2 Hz. For example, a logging rate of 10 Hz would reduce the velocity latency to 0.005 seconds. For integration purposes, the velocity latency should be applied to the record time tag.

A valid solution with a latency of 0.0 indicates that the instantaneous Doppler measurement was used to calculate velocity.

Message ID: 100

Log Type: Synch

Field #	Field type	Data Description	Format	Binary Bytes	Binary Offset
1	header	Log header		H	0
2	sol status	Solution status, see <i>Table 48, Solution Status on Page 163</i>	Enum	4	H
3	vel type	Velocity type, see <i>Table 47, Position or Velocity Type on Page 162</i>	Enum	4	H+4
4	latency	A measure of the latency in the velocity time tag in seconds. It should be subtracted from the time to give improved results.	Float	4	H+8
5	age	Differential age in seconds	Float	4	H+12
6	hor spd	Horizontal speed over ground, in meters per second	Double	8	H+16
7	trk gnd	Actual direction of motion over ground (track over ground) with respect to True North, in degrees	Double	8	H+24
8	vert spd	Vertical speed, in meters per second, where positive values indicate increasing altitude (up) and negative values indicate decreasing altitude (down)	Double	8	H+32
9	Reserved		Float	4	H+40
10	xxxx	32-bit CRC (ASCII and Binary only)	Hex	4	H+44
11	[CR][LF]	Sentence terminator (ASCII only)	-	-	-

Recommended Input:

log psrvela ontime 1

ASCII Example:

```
#PSRVELA, COM1, 0, 67.0, FINESTEERING, 1263, 245820.000, 00000000, 658b, 1522;  
SOL_COMPUTED, PSRDIFF, 0.250, 10.000, 0.0369, 351.259474, -0.0109, 0.0*ea9b653f
```

3.4.46 PSRXYZ Pseudorange Cartesian Position and Velocity

This log contains the receiver's pseudorange position and velocity in ECEF coordinates. The position and velocity status field's indicate whether or not the corresponding data is valid. See *Figure 8, Page 170* for a definition of the ECEF coordinates.

The velocity measurements sometimes have a latency associated with them. The time of validity is the time tag in the log minus the latency value.

The velocity status indicates varying degrees of velocity quality. To ensure healthy velocity, the position sol-status must also be checked. If the sol-status is non-zero, the velocity will likely be invalid. It should be noted that the receiver does not determine the direction of a vessel, craft, or vehicle is pointed (heading), but rather the direction of the motion of the GPS antenna relative to the ground.

The velocity is computed using Doppler values typically derived from differences in consecutive carrier phase measurements. As such, it is an average velocity based on the average change in pseudorange over the time interval and not an instantaneous velocity at the PSRVEL time tag. The velocity latency to be subtracted from the time tag will normally be 1/2 the time between filter updates. Under default operation, the position filter is updated at a rate of 2 Hz. This translates into a velocity latency of 0.25 second. The latency can be reduced by increasing the update rate of the filter by requesting the BESTXYZ message at a rate higher than 2 Hz. For example, a logging rate of 10 Hz would reduce the velocity latency to 0.005 seconds. For integration purposes, the velocity latency should be applied to the record time tag.

A valid solution with a latency of 0.0 indicates that the instantaneous Doppler measurement was used to calculate velocity.

Message ID: 243
Log Type: Synch

Field #	Field type	Data Description	Format	Binary Bytes	Binary Offset
1	header	Log header		H	0
2	P-sol status	Solution status, see <i>Table 48, Solution Status on Page 163</i>	Enum	4	H
3	pos type	Position type, see <i>Table 47, Position or Velocity Type on Page 162</i>	Enum	4	H+4
4	P-X	Position X-coordinate (m)	Double	8	H+8
5	P-Y	Position Y-coordinate (m)	Double	8	H+16
6	P-Z	Position Z-coordinate (m)	Double	8	H+24
7	P-X σ	Standard deviation of P-X (m)	Float	4	H+32
8	P- Y σ	Standard deviation of P-Y (m)	Float	4	H+36
9	P-Z σ	Standard deviation of P-Z (m)	Float	4	H+40
10	V-sol status	Solution status, see <i>Table 48, Solution Status on Page 163</i>	Enum	4	H+44
11	vel type	Velocity type, see <i>Table 47, Position or Velocity Type on Page 162</i>	Enum	4	H+48
12	V-X	Velocity vector along X-axis (m)	Double	8	H+52
13	V-Y	Velocity vector along Y-axis (m)	Double	8	H+60
14	V-Z	Velocity vector along Z-axis (m)	Double	8	H+68

Continued on Page 235

Field #	Field type	Data Description	Format	Binary Bytes	Binary Offset
15	V-X σ	Standard deviation of V-X (m)	Float	4	H+76
16	V-Y σ	Standard deviation of V-Y (m)	Float	4	H+80
17	V-Z σ	Standard deviation of V-Z (m)	Float	4	H+84
18	stn ID	Base station ID	Char[4]	4	H+88
19	V-latency	A measure of the latency in the velocity time tag in seconds. It should be subtracted from the time to give improved results.	Float	4	H+92
20	diff_age	Differential age in seconds	Float	4	H+96
21	sol_age	Solution age in seconds	Float	4	H+100
22	#obs	Number of observations tracked	Uchar	1	H+104
23	#GPSL1	Number of GPS L1 ranges used in computation	Uchar	1	H+105
24	Reserved		Char	1	H+106
25			Char	1	H+107
26			Char	1	H+108
27			Char	1	H+109
28			Char	1	H+110
29			Char	1	H+111
30	xxxx	32-bit CRC (ASCII and Binary only)	Hex	4	H+112
31	[CR][LF]	Sentence terminator (ASCII only)	-	-	-

Recommended Input:

```
log psrxyza ontime 1
```

ASCII Example:

```
#PSRXYZA,COM1,0,68.5,FINESTEERING,1263,245891.000,00000000,c0a5,1522;
SOL_COMPUTED,PSRDIFF,-1634532.4104,-3664608.9516,4942482.7843,0.8875,
1.5396,1.3041,SOL_COMPUTED,PSRDIFF,0.0272,0.0359,-0.0249,0.1061,0.1840,
0.1559,"AAAA",0.250,1.000,0.000,9,9,0,0,0,0,0,0,0*96723e6
```

3.4.47 RANGE Satellite Range Information

RANGE contains the channel measurements for the currently tracked satellites. When using this log, please keep in mind the constraints noted along with the description.

It is important to ensure that the receiver clock has been set. This can be monitored by the bits in the *Receiver Status* field of the log header. Large jumps in pseudorange as well as accumulated Doppler range (ADR) will occur as the clock is being adjusted. If the ADR measurement is being used in precise phase processing, it is important not to use the ADR if the "parity known" flag in the *ch-tr-status* field is not set as there may exist a half (1/2) cycle ambiguity on the measurement. The tracking error estimate of the pseudorange and carrier phase (ADR) is the thermal noise of the receiver tracking loops only. It does not account for possible multipath errors or atmospheric delays.

If both the L1 and L2 signals are being tracked for a given PRN, two entries with the same PRN will appear in the range logs. As shown in *Table 62, Channel Tracking Status* on *Page 237*, these entries can be differentiated by bit 20, which is set if there are multiple observables for a given PRN, and bits 21-22, which denotes whether the observation is for L1 or L2. This is to aid in parsing the data.

Table 62: Channel Tracking Status

Nibble #	Bit #	Mask	Description	Range Value
N0	0	0x00000001	Tracking state	0-11, see <i>Table 64, Tracking State on Page 239</i>
	1	0x00000002		
	2	0x00000004		
	3	0x00000008		
N1	4	0x00000010	SV channel number	0-n (0 = first, n = last) n depends on the receiver
	5	0x00000020		
	6	0x00000040		
N2	7	0x00000080	Phase lock flag	0 = Not locked, 1 = Locked
	8	0x00000100		
	9	0x00000200		
N3	10	0x00000400	Parity known flag	0 = Not known, 1 = Known
	11	0x00000800	Code locked flag	0 = Not locked, 1 = Locked
	12	0x00001000	Correlator spacing	0-7, see <i>Table 65, Correlator Spacing on Page 239</i>
	13	0x00002000		
N4	14	0x00004000	Satellite system	0 = GPS, 1, 3-7 = Reserved, 2 = WAAS
	15	0x00008000		
	16	0x00010000		
	17	0x00020000		
N5	18	0x00040000	Reserved	
	19	0x00080000	Grouping ^a	0 = Not grouped, 1 = Grouped
	20	0x00100000	Frequency	0 = L1, 1 = L2, 2-3 = Reserved
	21	0x00200000	Code type	0 = C/A, 1 = P, 2 = P codeless 3-7 = Reserved
22	0x00400000			
N6	23	0x00800000	Forward Error Correction	0 = Not FEC, 1 = FEC
	24	0x01000000		
	25	0x02000000		
N7	26	0x04000000	Primary L1 channel	0 = Not primary, 1 = Primary
	27	0x08000000	Carrier phase measurement ^b	0 = Half Cycle Not Added, 1 = Half Cycle Added
	28	0x10000000		
	29	Reserved		
N7	30	0x40000000	PRN lock flag ^c	0 = PRN Not Locked Out, 1 = PRN Locked Out
	31	0x80000000	Channel assignment	0 = Automatic, 1 = Forced

a. Grouped: Channel has an associated channel (L1/L2 pairs)

b. This bit will be zero until the parity is known and the parity known flag (bit 11) is set to 1.

c. A PRN can be locked out using the LOCKOUT command, see also *Page 89*.

Message ID: 43
Log Type: Synch

Field #	Field type	Data Description	Format	Binary Bytes	Binary Offset
1	header	Log header		H	0
2	# obs	Number of observations with information to follow ^a	Long	4	H
3	PRN	GPS satellite PRN number of range measurement	UShort	2	H+4
4	Reserved		UShort	2	H+6
5	psr	Pseudorange measurement (m)	Double	8	H+8
6	psr std	Pseudorange measurement standard deviation (m)	Float	4	H+16
7	adr	Carrier phase, in cycles (accumulated Doppler range)	Double	8	H+20
8	adr std	Estimated carrier phase standard deviation (cycles)	Float	4	H+28
9	dopp	Instantaneous carrier Doppler frequency (Hz)	Float	4	H+32
10	C/N ₀	Carrier to noise density ratio C/N ₀ = 10[log ₁₀ (S/N ₀)] (dB-Hz)	Float	4	H+36
11	locktime	Number of seconds of continuous tracking (no cycle slipping)	Float	4	H+40
12	ch-tr-status	Tracking status (see 62, <i>Channel Tracking Status on Page 237</i> and the example in <i>Table 63</i>)	ULong	4	H+44
13...	Next PRN offset = H + 4 + (#obs x 44)				
variable	xxxx	32-bit CRC (ASCII and Binary only)	Hex	4	H+4+ (#obs x 44)
variable	[CR][LF]	Sentence terminator (ASCII only)	-	-	-

- a. Some satellite PRN numbers may have two lines of observations, one for the L1 frequency and the other for L2.

Recommended Input:

log rangea ontime 30

ASCII Example:

```
#RANGEA, COM1, 0, 78.5, FINESTEERING, 1263, 245980.000, 00000000, 5103, 1522;
18,
29, 0, 23564951.224, 0.101, -123834693.971736, 0.019, 2717.438, 41.0, 2648.260,
08109c04,
29, 0, 23564956.856, 0.214, -96494599.645066, 0.020, 2117.480, 34.6, 2643.480,
01309c0b,
16, 0, 23957481.388, 0.112, -125897418.664850, 0.014, 2361.750, 40.2, 1218.990,
18109c44,
16, 0, 23957485.426, 0.248, -98101902.534034, 0.022, 1840.320, 33.2, 1219.000,
11309c4b,
...
30, 0, 23126046.425, 0.085, -121528145.931062, 0.010, -3505.320, 42.6, 14064.520,
08109d24,
30, 0, 23126051.798, 0.230, -94697247.029530, 0.015, -2731.426, 33.9, 14064.540,
01309d2b*529dccac
```

Table 63: Channel Tracking Example

Ox	N7				N6				N5				N4				N3				N2				N1				N0			
0x	0				8				1				0				9				C				0				4			
Bit #	31	30	29	28	27	26	25	24	23	22	21	20	19	18	17	16	15	14	13	12	11	10	9	8	7	6	5	4	3	2	1	0
Binary ^a	0	0	0	0	1	0	0	0	0	0	0	1	0	0	0	0	1	0	0	1	1	1	1	0	0	0	0	0	0	0	1	0
Data	Chan. Assignment		Reserved (R)		Primary L1		R	Code Type		Frequency		Grouping	R	Satellite System		Correlator Spacing		Code locked flag		Parity flag		Phase lock flag		Channel Number				Tracking State				
Value	Auto-matic				Primary			C/A		L1		Grouped		GPS		PAC		Locked		Known		Locked		Channel 0				L1 Phase Lock Loop				

- a. For a complete list of hexadecimal and binary equivalents please refer to the appendix on *Unit Conversion* in the *GPS+ Reference Manual* available on our website at <http://www.novatel.com/support/docupdates.htm>.

Table 64: Tracking State

State	Description	State	Description
0	L1 Idle	7	L1 Frequency-lock loop
1	L1 Sky search	8	L2 Idle
2	L1 Wide frequency band pull-in	9	L2 P code alignment
3	L1 Narrow frequency band pull-in	10	L2 Search
4	L1 Phase lock loop	11	L2 Phase lock loop
5	L1 Reacquisition	19	L2 Steering
6	L1 Steering		

Table 65: Correlator Spacing

State	Description
0	Reserved
1	Standard correlator: spacing = 1 chip
2	Narrow Correlator: spacing < 1 chip
3	Reserved
4	Pulse Aperture Correlator (PAC)

3.4.48 RANGECMP Compressed Version of the RANGE Log

Message ID: 140
Log Type: Synch

Field #	Field Type	Data Description	Format	Binary Bytes	Binary Offset
1	header	Log header		H	0
2	#obs	Number of satellite observations with information to follow.	Long	4	H
3	1st range record	Compressed range log in format of <i>Table 66</i>	Hex	24	H+4
4	Next rangecmp offset = H + 4 + (#obs x 24)				
variable	xxxx	32-bit CRC (ASCII and Binary only)	Hex	4	H + 4 + (#obs x 24)
variable	[CR][LF]	Sentence terminator (ASCII only)	-	-	-

Recommended Input:

log rangecmpa ontime 10

Example:

```
#RANGECMPA, COM1, 0, 69.5, FINESTEERING, 1263, 246632.000, 00000000, 9691, 1522;
18,
049c100824af09c0352b150b024a52b8501d889c01030000,
0b9c3001cb8b0720602b150bf54bc8d3731def9be1010000,
249c1018f946f76fce95440af5ea55c1200a72daa5030000,
2b9c3011fa33f9cfe895440ae5e58bbe200a73da05030000,
449c10180bec0760af354b0bb9ded2946110e0e9a0020000,
4b9c30114a2c06e0cb354b0b28411fb8a310e0e9c0010000,
649c1008b2bb09b01b55670abbd182aa201512ec81030000,
6b9c3001949507b02955670a89fbc2ac311512eca1020000,
849c1008bbd0f32f0245e20b12ad98b161184d3dca020000,
8b9c30016681f65f4145e20b8074cdeab418df3c6a010000,
a49c1008e0a50da02b9e3f0b0b0b709c811a4adea0020000,
ab9c300180a20a30619e3f0bf5030ebe931aafdde0010000,
c49c1018b3ac0e105b2bab0b7418cad571129f96a0020000,
cb9c30114b6f0b20902bab0b16170187b3122f96e0010000,
e49c1008209af76ffc63510aaabcecb820118e3287030000,
eb9c3001c574f95f1b64510a8740feb721118e32c7020000,
249d10081fdaf11f10083d0bb95e239e811e912fa7020000,
2b9d3001bff9f4df41083d0b4f6e61bfb31e912fa7010000*a5748b01
```

Table 66: Range Record Format (RANGECMP only)

Data	Bit(s) first to last	Length (bits)	Scale Factor	Units
Channel Tracking Status	0-31	32	see Table 62, Channel Tracking Status on Page 237	-
Doppler Frequency	32-59	28	1/256	Hz
Pseudorange (PSR)	60-95	36	1/128	m
ADR ^a	96-127	32	1/256	cycles
StdDev-PSR	128-131	4	see ^b	m
StdDev-ADR	132-135	4	(n + 1)/512	cycles
PRN	136-143	8	1	-
Lock Time ^c	144-164	21	1/32	s
C/No ^d	165-169	5	(20 + n)	dB-Hz
Reserved	170-191	22		

a. ADR (Accumulated Doppler Range) is calculated as follows:

$$\text{ADR_ROLLS} = (\text{RANGECMP_PSR} / \text{WAVELENGTH} + \text{RANGECMP_ADR}) / \text{MAX_VALUE}$$

Round to the closest integer

IF (ADR_ROLLS ≤ 0)

$$\text{ADR_ROLLS} = \text{ADR_ROLLS} - 0.5$$

ELSE

$$\text{ADR_ROLLS} = \text{ADR_ROLLS} + 0.5$$

At this point integerise ADR_ROLLS

$$\text{CORRECTED_ADR} = \text{RANGECMP_ADR} - (\text{MAX_VALUE} * \text{ADR_ROLLS})$$

where

ADR has units of cycles

WAVELENGTH = 0.1902936727984 for L1

WAVELENGTH = 0.2442102134246 for L2

MAX_VALUE = 8388608

b.

Code	StdDev-PSR (m)
0	0.050
1	0.075
2	0.113
3	0.169
4	0.253
5	0.380
6	0.570
7	0.854
8	1.281
9	2.375
10	4.750
11	9.500
12	19.000
13	38.000
14	76.000
15	152.000

c. Lock time rolls over after 2,097,151 seconds.

d. C/No is constrained to a value between 20-51 dB-Hz. Thus, if it is reported that C/No = 20 dB-Hz, the actual value could be less. Likewise, if it is reported that C/No = 51 dB-Hz, the true value could be greater.

3.4.49 RANGEGPSL1 L1 Version of the RANGE Log

This log is identical to the RANGE log, see *Page 236*, except that it only includes L1 GPS observations.

Message ID: 631
Log Type: Synch

Field #	Field type	Data Description	Format	Binary Bytes	Binary Offset
1	header	Log header		H	0
2	# obs	Number of L1 observations with information to follow	Long	4	H
3	PRN	GPS satellite PRN number of range measurement	UShort	2	H+4
4	Reserved		UShort	2	H+6
5	psr	Pseudorange measurement (m)	Double	8	H+8
6	psr std	Pseudorange measurement standard deviation (m)	Float	4	H+16
7	adr	Carrier phase, in cycles (accumulated Doppler range)	Double	8	H+20
8	adr std	Estimated carrier phase standard deviation (cycles)	Float	4	H+28
9	dopp	Instantaneous carrier Doppler frequency (Hz)	Float	4	H+32
10	C/N ₀	Carrier to noise density ratio C/N ₀ = 10[log ₁₀ (S/N ₀)] (dB-Hz)	Float	4	H+36
11	locktime	Number of seconds of continuous tracking (no cycle slipping)	Float	4	H+40
12	ch-tr-status	Tracking status (see 62, <i>Channel Tracking Status on Page 237</i>)	ULong	4	H+44
13...	Next PRN offset = H + 4 + (#obs x 44)				
variable	xxxx	32-bit CRC (ASCII and Binary only)	Hex	4	H+4+ (#obs x 44)
variable	[CR][LF]	Sentence terminator (ASCII only)	-	-	-

Recommended Input:

log rangea ontime 30

ASCII Example:

```
#RANGEGPSL1A, COM1, 0, 70.5, FINESTEERING, 1263, 246723.000, 00000000, 5862, 1522;
9,
29, 0, 23199473.208, 0.070, -121914103.478085, 0.010, 2442.504, 44.2,
3391.260, 08109c04,
10, 0, 21572439.996, 0.039, -113363992.231497, 0.005, -2279.199, 49.4,
12078.570, 18109c24,
16, 0, 23650098.774, 0.100, -124282114.716141, 0.014, 1978.891, 41.1,
1961.990, 18109c44,
...
30, 0, 23631470.601, 0.108, -124184149.366874, 0.015, -3634.508, 40.5,
14807.520, 08109d24*f7103bb9
```

3.4.50 RAWALM Raw Almanac Data

This log contains the undecoded almanac subframes as received from the satellite. For more information on Almanac data, refer to the GPS SPS Signal Specification (refer to the *Standards and References* section of the *GPS+ Reference Manual* available on our website at <http://www.novatel.com/support/docupdates.htm>).

The OEM4 family of receivers automatically saves almanacs in their non-volatile memory (NVM), therefore creating an almanac boot file is not necessary.

Message ID: 74

Log Type: Asynch

Field #	Field type	Data Description	Format	Binary Bytes	Binary Offset
1	header	Log header		H	0
2	ref week	Almanac reference week number	Ulong	4	H
3	ref secs	Almanac reference time (seconds.)	Ulong	4	H+4
4	subframes	Number of subframes to follow	Ulong	4	H+8
5	svid	SV ID (satellite vehicle ID) ^a	UShort	2	H+12
6	data	Subframe page data.	Hex	30	H+14
7...	Next subframe offset = H + 12 + (subframe x 32)				
variable	xxxx	32-bit CRC (ASCII and Binary only)	Hex	4	H + 12 + (32 x subframes)
variable	[CR][LF]	Sentence terminator (ASCII only)	-	-	-

- a. A value between 1 and 32 for the SV ID indicates the PRN of the satellite. Any other values indicate the page ID. See section 20.3.3.5.1.1, *Data ID and SV ID*, of ICD-GPS-200C for more details. To obtain copies of ICD-GPS-200, see ARINC in the *Standards/References* appendix in the *GPS+ Reference Manual*.

Recommended Input:

log rawalma onchanged

ASCII Example:

```
#RAWALMA, COM1, 0, 74.0, SATTIME, 1263, 246828.000, 00000000, cc1b, 1522;
1263, 405504.000, 42,
3, 8b03bc501bb7432d0263f706fd4000a10cfd24d4a7168fe9ac857b0c0037,
27, 8b03bc501db05b94486303eafd3f00a10db0d04430a707b230bf53060154,
4, 8b03bc501e344436a3630ba6fd3700a10c815375d7fd337635ae16f3ffa8,
28, 8b03bc5020335c46d9630b17fd5600a10d25fd86359e222df5e9e403000c,
5, 8b03bc5020b5452a5e63fbf6fd3e00a10e14fa38bf21db2e2c1c3a030002,
...
25, 8b03bc505731595c836300f5fd3a00a10ccacf1f3cbeb5b46f9210080008,
2, 8b03bc5057b742c15c63f9b1fd3effa10c93f9360cbaefbe2e0c93d8ffdf,
26, 8b03bc5059b25a7c8863190bfd6900a10cd8a83edc16cb9b9b76b532ff84*6181a963
```

3.4.51 RAWEPHEM Raw Ephemeris

This log contains the raw binary information for subframes one, two and three from the satellite with the parity information removed. Each subframe is 240 bits long (10 words - 24 bits each) and the log contains a total 720 bits (90 bytes) of information (240 bits x 3 subframes). This information is preceded by the PRN number of the satellite from which it originated. This message will not be generated unless all 10 words from all 3 frames have passed parity.

Ephemeris data whose TOE (Time Of Ephemeris) is older than six hours will not be shown.

Message ID: 41

Log Type: Asynch

Field #	Field type	Data Description	Format	Binary Bytes	Binary Offset
1	header	Log header		H	0
2	prn	Satellite PRN number	Ulong	4	H
3	ref week	Ephemeris reference week number	Ulong	4	H+4
4	ref secs	Ephemeris reference time (seconds)	Ulong	4	H+8
5	subframe1	Subframe 1 data.	Hex	30	H+12
6	subframe2	Subframe 2 data.	Hex	30	H+42
7	subframe3	Subframe 3 data.	Hex	30	H+72
8	xxxx	32-bit CRC (ASCII and Binary only)	Hex	4	H+102
9	[CR][LF]	Sentence terminator (ASCII only)	-	-	-

Recommended Input:

log rawephema unchanged

ASCII Example:

```
#RAWEPHEMA, COM1, 14, 76.5, SATTIME, 1262, 423540.000, 00000000, 97b7, 1522;
6, 1262, 424800,
8b03b889dfa53b90fc34bd9822236338ad0a49f6f64067b600fff6ff9d30,
8b03b889ddaa4005623c88c5c5720005050337cb8109aaa10c4b2067b646,
8b03b889de2e00452c14c2d3003c2622ba2d2244ad6bc049ffa1e1401229*d219ae03
#RAWEPHEMA, COM1, 13, 76.5, SATTIME, 1263, 247140.000, 00000000, 97b7, 1522;
29, 1263, 251984,
8b03bc5073a63bd00035c075bb505194c87c4ecaf2143d850000e1ec565,
8b03bc50742a14035d2b9f65c9e412032604434f521521a10da5353d8524,
8b03bc5074ac0033a6f9ba41fffb27d70d2e1768c689c5d1ffac78140e77*bd8345b6
...
#RAWEPHEMA, COM1, 0, 76.5, SATTIME, 1263, 247140.000, 00000000, 97b7, 1522;
18, 1263, 252000,
8b03bc5073a63bd1013dc075bb505194c87c4ecaea2b3d8600ffe7fd426a,
8b03bc50742a2bf3ee2f4d9018e31af59c02532bda13c1a10d3e4d3d867f,
8b03bc5074acffe47f168d1cffe4274ab4e018c488137253ffa9172b1f1c1*12437bb6
```

3.4.52 RAWGPSSUBFRAME Raw Subframe Data

This log contains the raw GPS subframe data.

A raw GPS subframe is 300 bits in total. This includes the parity bits which are interspersed with the raw data ten times in six bit chunks, for a total of 60 parity bits. Note that in Field #5, the 'data' field below, we have stripped out these 60 parity bits, and only the raw subframe data remains, for a total of 240 bits. There are two bytes added onto the end of this 30 byte packed binary array to pad out the entire data structure to 32 bytes in order to maintain 4 byte alignment.

Message ID: 25
Log Type: Asynch

Field #	Field type	Data Description	Format	Binary Bytes	Binary Offset
1	header	Log header		H	0
2	decode #	Frame decoder number	Ulong	4	H
3	PRN	Satellite PRN number	Ulong	4	H+4
4	subfr id	Subframe ID	Ulong	4	H+8
5	data	Raw subframe data	Hex[30]	32 ^a	H+12
6	chan	Signal channel number that the frame was decoded on.	Ulong	4	H+44
7	xxxx	32-bit CRC (ASCII and Binary only)	Hex	4	H+48
8	[CR][LF]	Sentence terminator (ASCII only)	-	-	-

- a. In the binary log case an additional 2 bytes of padding are added to maintain 4 byte alignment

Recommended Input:

```
log rawgpssubframea onnew
```

ASCII Example:

```
#RAWGPSSUBFRAMEA,COM1,54,72.0,SATTIME,1263,236412.000,00000000,f690,1522;
16,9,3,8b03bc4cf5ae0031d1304bb9ff9926bdc7bf244729e91722ffa6e348061b,
16*17f7348d
...
#RAWGPSSUBFRAMEA,COM1,4,72.0,SATTIME,1263,247440.000,00000000,f690,1522;
18,30,1,8b03bc508ca73bd00135c075bb505194c87c4ecae5a3d860000676ce806,
18*dcefc53
#RAWGPSSUBFRAMEA,COM1,3,72.0,SATTIME,1263,247446.000,00000000,f690,1522;
18,30,2,8b03bc508d295afbe2339a6ee39617fc7103c0ff19150da10d8d723d867c,
18*5b14e101
...
#RAWGPSSUBFRAMEA,COM1,0,72.0,SATTIME,1263,247434.000,00000000,f690,1522;
18,30,5,8b03bc508c3440aaaaaaaaaaaaaaaaaaaaaaaaaaaaaaaaaaaaaaaaaaaaaaaaaaaa,
18*c654525a
```

3.4.53 RAWGPSWORD Raw Navigation Word

This message contains the framed raw navigation words. Each log contains a new 30 bit navigation word (in the least significant 30 bits), plus the last 2 bits of the previous word (in the most significant 2 bits). The 30 bit navigation word contains 24 bits of data plus 6 bits of parity. The GPS time stamp in the log header is the time that the first bit of the 30 bit navigation word was received. Only navigation data that has passed parity checking will appear in this log. One log will appear for each PRN being tracked every 0.6 seconds if logged ONNEW or ONCHANGED.

Message ID: 407

Log Type: Asynch

Field #	Field type	Data Description	Format	Binary Bytes	Binary Offset
1	header	Log header		H	0
2	PRN	Satellite PRN number	Ulong	4	H
3	nav word	Raw navigation word	Ulong	4	H+4
4	xxxx	32-bit CRC (ASCII and Binary only)	Hex	4	H+8
5	[CR][LF]	Sentence terminator (ASCII only)	-	-	-

Recommended Input:

```
log rawgpsworda onnew
```

ASCII Example:

```
#RAWGPSWORDA, COM1, 0, 72.0, FINESTEERING, 1263, 247930.270, 00000000, 9b16, 1522;
21, 7edc5796*3103d12f
#RAWGPSWORDA, COM1, 0, 72.0, FINESTEERING, 1263, 247930.875, 00000000, 9b16, 1522;
26, 7cb4b5f0*5b4c3a6c
#RAWGPSWORDA, COM1, 0, 72.0, FINESTEERING, 1263, 247930.873, 00000000, 9b16, 1522;
17, 832c812b*e0602fc9
...
#RAWGPSWORDA, COM1, 0, 70.0, FINESTEERING, 1263, 247936.883, 00000000, 9b16, 1522;
15, c01768e3*1430a655
```

3.4.54 RAWLBANDFRAME Raw L-Band Frame Data

This log contains the raw L-Band frame data if you are tracking CDGPS. The RAWBANDPACKET is output for OmniSTAR tracking.

-
- ☒ 1. In addition to a NovAtel receiver with L-Band capability, use of the free CDGPS service is required. Contact NovAtel for details. Contact information may be found on the back of this manual or you can refer to the *Customer Service* section in *Volume 1* of this manual set.
 - 2. The RAWOMNIFRAME log is still available to OmniSTAR users but will be made obsolete in a future firmware release. Please use the RAWBANDPACKET log instead, see *Page 248*.
-

Message ID: 732
Log Type: Asynch

Field #	Field type	Data Description	Format	Binary Bytes	Binary Offset
1	header	Log header		H	0
2	frame#	Frame number	Ushort	2	H+2
3	channelcode	10 bit channel code word	Ushort	2	H+4
4	data	Raw L-Band frame data	Uchar[1200]	1200	H+6
5	xxxx	32-bit CRC (ASCII and Binary only)	Hex	4	H+1206
6	[CR][LF]	Sentence terminator (ASCII only)	-	-	-

Recommended Input:

log rawbandframea onnew

ASCII Example:

```
#RAWLBANDFRAMEA,COM2,0,73.5,FINESTEERING,1295,152802.068,00000040,4f80,34461;
9,1a1e,600,f6,00,62,35,c8,cd,34,e7,6a,a1,37,44,8f,a8,24,71,90,d0,5f,94,2d,94,
3c,74,9c,f0,12,a3,4c,a7,30,aa,b6,2e,27,dd,dc,24,ba,d3,76,8d,76,d9,e7,83,1a,c8
,81,b0,62,1c,69,88,23,70,2a,06,c0,fc,f8,80,2c,72,f1,2e,6b,c2,5b,ec,03,70,d3,f
3,fe,ef,37,3d,17,37,1b,cf,be,af,d1,02,15,96,d1,f6,58,56,ac,bd,a3,11,12,d0,3d,
11,27,8a,87,28,0c,0f,52,70,b3,2f,0c,0c,62,2d,b8,69,6c,52,10,df,7d,bb,08,d6,ca
,a9,5e,77,66,96,c2,a0,63,3b,98,34,bc,d5,47,64,e0,00,37,10,4a,f7,c1,b6,83,8f,0
6,94,21,ff,b4,27,15,b0,60,40,02,b4,af,9c,9d,c2,d4,ea,95,68,86,0f,0a,9d,2d,36,
52,68,65,b8,a2,0b,00,21,80,64,8a,72,ff,59,b7,79,b9,49,fd,f5,3c,48,1c,2f,77,f1
,b2,9e,58,0a,81,05,1f,00,7b,00,1e,68,c9,a3,12,56,b8,2a,32,df,d9,ea,03,9b,16,c
6,17,2f,33,b3,5f,c4,f9,d2,97,75,64,06,52,a1,b2,3a,4b,69,e7,eb,0f,97,d3,e6,bf,
de,af,37,c6,10,13,9b,dc,c9,e3,22,80,78,3f,78,90,d5,9f,d3,5f,af,1f,7a,75,ef,77
,8e,de,ac,00,32,2e,79,fb,3f,65,f3,4f,28,77,b4,6d,f2,6f,31,24,b2,40,76,37,27,b
c,95,33,15,01,76,d5,f1,c4,75,16,e6,c6,ab,f2,fe,34,d9,c3,55,85,61,49,e6,a4,4e,
8b,2a,60,57,8a,e5,77,02,fc,9c,7d,d4,40,4c,1d,11,3c,9b,8e,c3,73,d3,3c,0d,ff,18
.
.
.
,7a,21,05,cb,12,f6,dd,c3,df,69,62,f5,70*3791693b
```

3.4.55 RAWLBANDPACKET Raw L-Band Data Packet

This log contains the raw L-Band packet data. The RAWLBANDPACKET log is only output for OmniSTAR tracking. If you are tracking CDGPS, only the RAWLBANDFRAME log is output.

-
- ☒ 1. In addition to a NovAtel receiver with L-Band capability, a subscription to the OmniSTAR service is required. Contact NovAtel for details. Contact information may be found on the back of this manual or you can refer to the *Customer Service* section in *Volume 1* of this manual set.
 - 2. The RAWOMNIPACKET log is still available to OmniSTAR users but will be made obsolete in a future firmware release. Please use the RAWLBANDPACKET log instead.
-

Message ID: 733
Log Type: Asynch

Field #	Field type	Data Description	Format	Binary Bytes	Binary Offset
1	header	Log header		H	0
2	#bytes	Number of bytes to follow	Ulong	4	H
3	data	Raw L-Band data packet.	Uchar[128]	#bytes (up to 128)	H+4
4	xxxx	32-bit CRC (ASCII and Binary only)	Hex	4	H+4+ #bytes
5	[CR][LF]	Sentence terminator (ASCII only)	-	-	-

Recommended Input:

log rawbandpacketa onnew

ASCII Example:

```
#RAWLBANDPACKETA,COM2,0,77.0,FINESTEERING,1295,238642.610,01000040,c5b1,34461;9,07,de,3a,f9,df,30,7b,0d,cb*7e5205a8
```

3.4.57 REFSTATION Base Station Position and Health RTK

This log contains the ECEF Cartesian position of the base station as received through the RTCM, RTCMV3, RTCA, or CMR message. It also features a time tag, the health status of the base station, and the station ID. This information is set at the base station using the FIX POSITION command and the DGPSTXID command. See *Figure 8, Page 170* for a definition of the ECEF coordinates.

The base station health, Field #6, may be one of 8 values (0 to 7). Values 0 through 5 indicate the scale factor that multiply satellite UDRE one-sigma differential error values. Below are values 0 to 5 and their corresponding UDRE scale factors:

0: 1 (Health OK) 1: 0.75 2: 0.5 3: 0.3 4: 0.2 5: 0.1

The base station health field only applies to RTCM base stations. A value of 6 means that the base station transmission is not monitored and a value of 7 means that the base station is not working.

Message ID: 175
Log Type: Asynch

Field #	Field type	Data Description	Format	Binary Bytes	Binary Offset
1	header	Log header		H	0
2	status	Status of the base station information (see <i>Table 67</i> below)	ULong	4	H
3	x	ECEF X value	Double	8	H+4
4	y	ECEF Y value	Double	8	H+12
5	z	ECEF Z value	Double	8	H+20
6	health	Base station health, see the 2nd paragraph above	ULong	4	H+28
7	stn type	Base station type (see <i>Table 68, Base Station Type</i> on <i>Page 251</i>)	Enum	4	H+32
8	stn ID	Base station ID	Char[5]	g ^a	H+36
9	xxxx	32-bit CRC (ASCII and Binary only)	Hex	4	H+44
10	[CR][LF]	Sentence terminator (ASCII only)	-	-	-

- a. In the binary log case an additional 3 bytes of padding are added to maintain 4 byte alignment

Recommended Input:

log refstationa onchanged

ASCII Example:

```
#REFSTATIONA, COM1, 0, 65.0, FINESTEERING, 1263, 327030.000, 00000100, 4e46, 1522;
00000000, -1634529.233, -3664611.942, 4942481.496, 0, RTCA, "AAAA"*e4c61a4b
```

Table 67: Base Station Status

Bit #	Mask	Description	Bit = 0	Bit = 1
0	0x00000001	Validity of the base station.	Valid	Invalid

Table 68: Base Station Type

Base Station Type		Description
(Binary)	(ASCII)	
0	NONE	Base station is not used
1	RTCM	Base station is RTCM
2	RTCA	Base station is RTCA
3	CMR	Base station is CMR
4	RTCMV3	Base station is RTCMV3

3.4.58 RTCA Standard Logs DGPS

RTCA1 DIFFERENTIAL GPS CORRECTIONS

Message ID: 10

RTCAEPHEM EPHEMERIS AND TIME INFORMATION

Message ID: 347

RTCAOBS BASE STATION OBSERVATIONS *RTK*

Message ID: 6

RTCAREF BASE STATION PARAMETERS *RTK*

Message ID: 11

The RTCA (Radio Technical Commission for Aviation Services) Standard is being designed to support Differential Global Navigation Satellite System (DGNSS) Special Category I (SCAT-I) precision instrument approaches. The RTCA Standard is in a preliminary state. NovAtel's current support for this Standard is based on "Minimum Aviation System Performance Standards DGNSS Instrument Approach System: SCAT-I" dated August 27, 1993.

The above messages can be logged with an A or B suffix for an ASCII or Binary output with a NovAtel header followed by Hex or Binary raw data respectively.

See the chapter on *Message Formats* in *Volume 1* of this manual set for more information on RTCA standard logs.

Example Input:

```
interfacemode com2 none RTCA
fix position 51.1136 -114.0435 1059.4
log com2 rtcaobs ontime 2
log com2 rtcaref ontime 10
log com2 rtca1 ontime 10 3
log com2 rtcaephem ontime 10 7
```

3.4.59 RTCADATA1 Differential GPS Corrections DGPS

See the chapter on *Message Formats* in *Volume 1* of this manual set for information on RTCA standard logs.

Message ID: 392

Log Type: Synch

Field #	Field type	Data Description	Format	Binary Bytes	Binary Offset
1	header	Log header	-	H	0
2	z-count	Modified Z count where the Z count week number is the week number from subframe 1 of the ephemeris.	Double	8	H
3	AEB	Acceleration Error Bound, the receiver report this field as 0	Uchar	4 ^a	H+8
4	#prn	Number of satellite corrections with information to follow	Ulong	4	H+12
5	prn	PRN number of satellite	Ulong	4	H+16
6	range	Pseudorange correction (m)	Double	8	H+20
7	IODE	Issue of ephemeris data	Uchar	4 ^a	H+28
8	range rate	Pseudorange rate correction (m/s)	Double	8	H+32
9	UDRE	User differential range error	Float	4	H+40
10...	Next prn offset = H+16 + (#prns x 28)				
variable	xxxx	32-bit CRC (ASCII and Binary only)	Hex	4	variable
variable	[CR][LF]	Sentence terminator (ASCII only)	-	-	-

- a. In the binary log case an additional 3 bytes of padding are added to maintain 4 byte alignment

Recommended Input:

```
log rtcadata1a ontime 10 3
```

ASCII Example:

```
#RTCADATA1A,COM1,0,79.0,FINESTEERING,1263,327253.000,80180000,606b,1516;
853.000000000,0,9,
10,-7.174726857,179,-0.002809814,1.000000000,
25,-35.917011053,168,-0.006853780,1.000000000,
4,-24.536462551,39,-0.020870491,1.000000000,
24,-4.684821825,67,-0.006354673,1.000000000,
21,-45.783389787,214,0.001092934,1.000000000,
13,-20.450797536,187,-0.003220624,1.000000000,
5,-23.566730594,190,-0.009295567,1.000000000,
17,-3.136731088,11,0.001613715,1.000000000,
30,-12.609691187,114,-0.005359172,1.000000000*1fb05021
```

3.4.60 RTCADATAEPHEM Epheris and Time Information DGPS & RTK

See the chapter on *Message Formats* in *Volume 1* of this manual set for information on RTCA standard logs.

Message ID: 393

Log Type: Synch

Field #	Field type	Data Description	Format	Binary Bytes	Binary Offset
1	header	Log header	-	H	0
2	des	NovAtel designator	Uchar	1	H
3	subtype	RTCA message subtype	Uchar	3 ^a	H+1
4	week	GPS week number (weeks)	Ulong	4	H+4
5	sec	Seconds into the week (seconds)	Ulong	4	H+8
6	prn	PRN number	Ulong	4	H+12
7	Reserved		Uchar	4 ^b	H+16
8	raw data	Raw ephemeris data	Hex[90]	92 ^a	H+20
9	xxxx	32-bit CRC (ASCII and Binary only)	Hex	4	H+112
10	[CR][LF]	Sentence terminator (ASCII only)	-	-	-

- In the binary log case an additional 2 bytes of padding are added to maintain 4 byte alignment
- In the binary log case an additional 3 bytes of padding are added to maintain 4 byte alignment

Recommended Input:

```
log rtcadataephema ontime 10 7
```

ASCII Example:

```
#RTCADATAEPHEMA, COM1, 0, 81.0, FINESTEERING, 1263, 327430.092, 80180000, d869, 1516;
78, 2, 239, 327430, 10, 0, 8b03bc6a93243bd10100b709bcc51acf2ae025dfbb350dc00000505
6ce08b03bc6a93a9b3f4ea2c7d26848989f6f7031c85f30f05a10d6f5950dc7f8b03bc6a942e0
0087db1d930003627f55fc01f1c0af06413ffa8f3b3ed52*807652fc
```

3.4.61 RTCADATAOBS Base Station Observations RTK

See the chapter on *Message Formats* in *Volume 1* of this manual set for information on RTCA standard logs.

Message ID: 394

Log Type: Synch

Field #	Field type	Data Description	Format	Binary Bytes	Binary Offset
1	header	Log header	-	H	0
2	des	NovAtel designator	Uchar	1	H
3	subtype	RTCA message subtype	Uchar	3 ^a	H+1
4	min psr	Minimum pseudorange	Double	8	H+4
5	sec	Seconds into the GPS week	Float	4	H+12
6	Reserved		Long	4	H+16
7	#prn	Number of PRNs with information to follow	Ulong	4	H+20
8	trans ID	Transmitter ID	Uchar	1	H+24
9	L1 lock	L1 lock flag	Uchar	1	H+25
10	L2 lock	L2 lock flag	Uchar	2 ^b	H+26
11	L1 psr	L1 pseudorange offset (2/10 m)	Double	8	H+28
12	L2 psr	L2 pseudorange offset (1/4 m)	Double	8	H+36
13	L1 ADR	L1 carrier phase offset, accumulated Doppler range (2/1000 m)	Float	4	H+44
14	L2 ADR	L2 carrier phase offset, accumulated Doppler range (3/1000 m)	Float	4	H+48
15	L2 encrypt	L2 not encrypted 0 = FALSE 1 = TRUE?	Enum	4	H+52
16	Reserved		Long	4	H+56
17...	Next PRN offset = H+24 + (#prns x 36)				
variable	xxxx	32-bit CRC (ASCII and Binary only)	Hex	4	variable
variable	[CR][LF]	Sentence terminator (ASCII only)	-	-	-

- a. In the binary log case an additional 2 bytes of padding are added to maintain 4 byte alignment
- b. In the binary log case an additional 1 byte of padding is added to maintain 4 byte alignment

Recommended Input:

log rtcadataobsa ontime 2

ASCII Example:

```
#RTCADATAOBSA, COM1, 0, 79.0, FINESTEERING, 1263, 327528.000, 80180000, 9025, 1516;  
78, 1, 2.0418258000000000e+07, 528.000000000, 0, 9,  
17, 3, 3, 0.600000000, 2.750000000, -3.914000034, -12.729000092, TRUE, 0,  
10, 3, 3, 545967.000000000, 3.000000000, -11.930000305, -39.618000031, TRUE, 0,  
30, 3, 3, 397982.600000000, 3.500000000, 1.567999959, 4.127999783, TRUE, 0,  
24, 3, 3, 1612129.200000000, 3.750000000, -2.221999884, -9.527999878, TRUE, 0,  
5, 3, 3, 2635047.200000000, 5.750000000, 13.055999756, 42.936000824, TRUE, 0,  
25, 3, 3, 4391931.000000000, 5.500000000, 2.125999928, 7.359000206, TRUE, 0,  
13, 3, 3, 4186734.000000000, 5.750000000, -2.332000017, -7.497000217, TRUE, 0,  
21, 3, 3, 4442245.600000001, 6.000000000, -1.595999956, -5.991000175, TRUE, 0,  
4, 3, 3, 4900679.200000000, 8.000000000, 12.512000084, 39.953998566, TRUE, 0*6c07fc73
```

3.4.62 RTCADATAREF Base Station Parameters RTK

See the chapter on *Message Formats* in *Volume 1* of this manual set for information on RTCA standard logs.

Message ID: 395

Log Type: Synch

Field #	Field type	Data Description	Format	Binary Bytes	Binary Offset
1	header	Log header	-	H	0
2	des	NovAtel designator.	Uchar	1	H
3	subtype	RTCA message subtype	Uchar	3 ^a	H+1
4	X pos	Base station X coordinate position (mm)	Double	8	H+4
5	Y pos	Base station Y coordinate position (mm)	Double	8	H+12
6	Z pos	Base station Z coordinate position (mm)	Double	8	H+20
7	Reserved		Uchar	4 ^b	H+28
8	xxxx	32-bit CRC (ASCII and Binary only)	Hex	4	H+32
9	[CR][LF]	Sentence terminator (ASCII only)	-	-	-

- a. In the binary log case an additional 2 bytes of padding are added to maintain 4 byte alignment
- b. In the binary log case an additional 3 bytes of padding are added to maintain 4 byte alignment

Recommended Input:

```
log rtcadatAREFA ontime 10
```

ASCII Example:

```
#RTCADATAREFA, COM1, 0, 79.5, FINESTEERING, 1263, 327635.325, 80180000, 44de, 1516;  
78, 0, -1634531.171086837, -3664611.077192585, 4942481.496500084, 0*1a2da9af
```

3.4.63 RTCM Standard Logs DGPS

RTCM1 DIFFERENTIAL GPS CORRECTIONS

Message ID: 107

RTCM3 BASE STATION PARAMETERS *RTK*

Message ID: 117

RTCM9 PARTIAL DIFFERENTIAL GPS CORRECTIONS
(OEM4-G2 with external oscillator only)

Message ID: 275

RTCM15 IONOSPHERIC CORRECTIONS

Message ID: 307

RTCM16 SPECIAL MESSAGE

Message ID: 129

RTCM16T SPECIAL TEXT MESSAGE, see also *Page 125*

Message ID: 131

RTCM1819 RAW MEASUREMENTS *RTK*

Message ID: 260

RTCM2021 MEASUREMENT CORRECTIONS *RTK*

Message ID: 374

RTCM22 EXTENDED BASE STATION *RTK*

Message ID: 118

RTCM59 TYPE 59N-0 NOVATEL PROPRIETARY RT20 DIFFERENTIAL *RTK*

Message ID: 116

The Radio Technical Commission for Marine Services (RTCM) was established to facilitate the establishment of various radio navigation standards, which includes recommended GPS differential standard formats.

The Standard recommended by the RTCM Special Committee 104, Differential GPS Service (RTCM SC-104, Washington, D.C.) have been adopted by NovAtel for implementation into the receiver. The receiver can easily be integrated into positioning systems around the globe because it is capable of utilizing RTCM formats.

The RTCM messages can be logged with an A or B suffix for an ASCII or Binary output with a NovAtel header followed by Hex or Binary raw data respectively.

See the chapter on *Message Formats* in *Volume 1* of this manual set for more information on RTCM standard logs.

Example Input:

```
interfacemode com2 none RTCM
fix position 51.1136 -114.0435 1059.4
log com2 rtm3 ontime 10
log com2 rtm22 ontime 10
log com2 rtm1819 ontime 2
```

3.4.64 RTCMDATA1 Differential GPS Corrections DGPS

See the chapter on *Message Formats* in *Volume 1* of this manual set for information on RTCM logs.

Message ID: 396

Log Type: Synch

Field #	Field type	Data Description	Format	Binary Bytes	Binary Offset
1	header	Log header	-	H	0
2	RTCM header	RTCM message type	Ulong	4	H
3		Base station ID	Ulong	4	H+
4		Modified Z count where the Z count week number is the week number from subframe 1 of the ephemeris	Ulong	4	H+8
5		Sequence number	Ulong	4	H+12
6		Length of frame	Ulong	4	H+16
7		Base station health, see <i>REFSTATION on Page 250</i>	Ulong	4	H+20
8		#prn	Number of PRNs with information to follow	Ulong	4
9	scale	Scale where 0 = 0.02 m and 0.002 m/s 1 = 0.32 m and 0.032 m/s	Ulong	4	H+28
10	UDRE	User differential range error	Ulong	4	H+32
11	prn	Satellite PRN number	Ulong	4	H+36
12	psr corr	Scaled pseudorange correction (meters)	Long	4	H+40
13	rate corr	Scaled range rate correction	Long	4	H+44
14	IOD	Issue of data	Long	4	H+48
15...	Next PRN offset = H+28 + (#prns x 24)				
variable	xxxx	32-bit CRC (ASCII and Binary only)	Hex	4	variable
variable	[CR][LF]	Sentence terminator (ASCII only)	-	-	-

Recommended Input:

```
log rtcmdata1a ontime 10 3
```

ASCII Example:

```
#RTCMDATA1A, COM1, 0, 73.0, FINESTEERING, 1117, 160453.000, 00100020, 5745, 399;
1117, 0, 3421, 8461020, 1730644, 6,
9,
0, 0, 3, -545, -46, 43,
0, 0, 15, -313, -44, 96,
0, 0, 18, -112, -41, 1,
0, 0, 21, -874, -43, 153,
0, 0, 6, -1368, -43, 88,
0, 0, 26, -398, -43, 35,
0, 0, 23, -123, -43, 167,
0, 0, 28, -1302, -39, 22,
0, 0, 22, -1515, -48, 27*b60bf22f
```

3.4.65 RTCMDATA3 Base Station Parameters RTK

See the chapter on *Message Formats* in *Volume 1* of this manual set for information on RTCM standard logs.

Message ID: 402

Log Type: Synch

Field #	Field type	Data Description	Format	Binary Bytes	Binary Offset
1	header	Log header	-	H	0
2	RTCM header	RTCM message type	Ulong	4	H
3		Base station ID	Ulong	4	H+4
4		Modified Z count where the Z count week number is the week number from subframe 1 of the ephemeris.	Ulong	4	H+8
5		Sequence number	Ulong	4	H+12
6		Length of frame	Ulong	4	H+16
7		Base station health, see <i>REFSTATION</i> on Page 250	Ulong	4	H+20
8	ECEF-X	Base station ECEF X-coordinate (1/100 m)	Double	8	H+24
9	ECEF-Y	Base station ECEF Y-coordinate (1/100 m)	Double	8	H+32
10	ECEF-Z	Base station ECEF Z-coordinate (1/100 m)	Double	8	H+40
11	xxxx	32-bit CRC (ASCII and Binary only)	Hex	4	H+48
12	[CR][LF]	Sentence terminator (ASCII only)	-	-	-

Recommended Input:

```
log rtcmdata3a ontime 10
```

ASCII Example:

```
#RTCMDATA3A,COM1,0,74.0,FINESTEERING,1117,160636.477,00100020,2e19,399;
1117,0,3727,160636477,180,6,
-163452535.7607752382755280,-366461076.2499782443046570,
494248361.4689489603042603*f621f163
```

3.4.66 RTCMDATA9 Partial Differential GPS Corrections DGPS

See the chapter on *Message Formats* in *Volume 1* of this manual set for information on RTCM standard logs. This log is the same as the RTCMDATA1 log but there will only be corrections for a maximum of 3 satellites.

Message ID: 404

Log Type: Synch

Field #	Field type	Data Description	Format	Binary Bytes	Binary Offset
1	header	Log header	-	H	0
2	RTCM header	RTCM message type	Ulong	4	H
3		Base station ID	Ulong	4	H+4
4		Modified Z count where the Z count week number is the week number from subframe 1 of the ephemeris.	Ulong	4	H+8
5		Sequence number	Ulong	4	H+12
6		Length of frame	Ulong	4	H+16
7		Base station health, see <i>REFSTATION on Page 250</i>	Ulong	4	H+20
8	#prn	Number of PRNs with information to follow (maximum of 3)	Ulong	4	H+24
9	scale	Scale where 0 = 0.02 m and 0.002 m/s 1 = 0.32 m and 0.032 m/s	Ulong	4	H+28
10	UDRE	User differential range error	Ulong	4	H+32
11	prn	Satellite PRN number	Ulong	4	H+36
12	psr corr	Scaled pseudorange correction (meters)	Long	4	H+40
13	rate corr	Scaled range rate correction	Long	4	H+44
14	IOD	Issue of data	Long	4	H+48
15...	Next PRN offset = H+28 + (#prns x 24)				
variable	xxxx	32-bit CRC (ASCII and Binary only)	Hex	4	variable
variable	[CR][LF]	Sentence terminator (ASCII only)	-	-	-

Recommended Input:

```
log rtcmdata9a ontime 10
```

ASCII Example:

```
#RTCMDATA9A,COM1,0,74.0,FINESTEERING,1117,160710.000,00100020,8265,399;
160710000,0,3850,0,1117,6,
3,
0,0,21,-866,-29,153,
0,0,6,-1438,-29,88,
0,0,26,-409,-30,35*818597db
```

3.4.67 RTCMDATA15 Ionospheric Corrections DGPS

See the chapter on *Message Formats* in *Volume 1* of this manual set for information on RTCM standard logs.

Message ID: 397

Log Type: Synch

Field #	Field type	Data Description	Format	Binary Bytes	Binary Offset
1	header	Log header	-	H	0
2	RTCM header	RTCM message type	Ulong	4	H
3		Base station ID	Ulong	4	H+4
4		Modified Z count where the Z count week number is the week number from subframe 1 of the ephemeris.	Ulong	4	H+8
5		Sequence number	Ulong	4	H+12
6		Length of frame	Ulong	4	H+16
7		Base station health, see <i>REFSTATION</i> on Page 250	Ulong	4	H+20
8		#prn	Number of PRNs with information to follow	Ulong	4
9	Reserved		Ulong	4	H+28
10	sat type	Satellite type where 0 = GPS 1 = GLONASS	Ulong	4	H+32
11	prn	Satellite PRN number	Ulong	4	H+36
12	ion delay	Ionospheric delay (cm)	Ulong	4	H+40
13	ion rate	Ionospheric rate (0.05 cm / min.)	Long	4	H+44
14...	Next PRN offset = H+28 + (#prns x 20)				
variable	xxxx	32-bit CRC (ASCII and Binary only)	Hex	4	variable
variable	[CR][LF]	Sentence terminator (ASCII only)	-	-	-

Recommended Input:

```
log rtcmdata15a ontime 10
```

ASCII Example:

```
#RTCMDATA15A, COM1, 0, 74.5, FINESTEERING, 1117, 160783.000, 00100020, 9601, 399;
15, 0, 3971, 7799968, 5163500, 6,
10,
0, 0, 3, 1631, 445,
0, 0, 15, 1423, -222,
0, 0, 18, 1275, -334,
0, 0, 21, 1763, -334,
0, 0, 17, 1454, -556,
0, 0, 6, 2063, 0,
0, 0, 26, 1579, 222,
0, 0, 23, 1423, -111,
0, 0, 28, 1874, 445,
0, 0, 22, 2146, -445*19ed193f
```

3.4.68 RTCMDATA16 Special Message DGPS & RTK

See the chapter on *Message Formats* in *Volume 1* of this manual set for information on RTCM standard logs.

Message ID: 398

Log Type: Synch

Field #	Field type	Data Description	Format	Binary Bytes	Binary Offset
1	header	Log header	-	H	0
2	RTCM header	RTCM message type	Ulong	4	H
3		Base station ID	Ulong	4	H+4
4		Modified Z count where the Z count week number is the week number from subframe 1 of the ephemeris	Ulong	4	H+8
5		Sequence number	Ulong	4	H+12
6		Length of frame	Ulong	4	H+16
7		Base station health, see <i>REFSTATION on Page 250</i>	Ulong	4	H+20
8	#chars	Number of characters to follow	Ulong	4	H+24
9	character	Character	Char	4 ^a	H+28
10...	Next PRN offset = H+28 + (#chars x 4)				
variable	xxxx	32-bit CRC (ASCII and Binary only)	Hex	4	variable
variable	[CR][LF]	Sentence terminator (ASCII only)	-	-	-

- a. In the binary log case an additional 3 bytes of padding are added to maintain 4 byte alignment

Recommended Input:

log rtcmdata16a once

ASCII Example:

```
#RTCMDATA16A, COM1, 0, 66.0, FINESTEERING, 1117, 161024.000, 00100020, e639, 399;
161024000, 0, 4373, 2243048, 6958196, 6, 21, "Base station will shut down in 1 hour"
*b6202f15
```

3.4.69 RTCMDATA1819 Raw Measurements RTK

See the chapter on *Message Formats* in *Volume 1* of this manual set for information on RTCM standard logs.

Message ID: 399
Log Type: Synch

Field #	Field type	Data Description	Format	Binary Bytes	Binary Offset
1	header	Log header	-	H	0
2	RTCM header (for RTCM18)	RTCM message type	Ulong	4	H
3		Base station ID	Ulong	4	H+4
4		Modified Z count where the Z count week number is the week number from subframe 1 of the ephemeris	Ulong	4	H+8
5		Sequence number	Ulong	4	H+12
6		Length of frame	Ulong	4	H+16
7		Base station health, see <i>REFSTATION</i> on Page 250	Ulong	4	H+20
8		freq	Frequency indicator where 0 = L1 2 = L2 (1 is reserved for future use)	Ulong	4
9	Reserved		Ulong	4	H+28
10	GNSS time	Global Navigation Satellite System (GNSS) time of measurement (microseconds)	Long	4	H+32
11	#obs	Number of observation with information to follow	Long	4	H+36
12	multi bit	Multiple message indicator	Ulong	4	H+40
13	code	Is code P Code? 0 = FALSE 1 = TRUE	Ulong	4	H+44
14	sat type	Satellite type 0 = GPS 1 = GLONASS	Ulong	4	H+48
15	prn	Satellite PRN number	Ulong	4	H+52
16	quality	Data quality indicator, see <i>Table 69, RTCM1819 Data Quality Indicator</i> on Page 267	Ulong	4	H+56
17	continuity	Cumulative loss of continuity indicator with a loss of lock counter	Ulong	4	H+60
18	phase	Carrier phase (1/256 cycles)	Long	4	H+64
19...	Next RTCM18 observation offset = H+40 + (#obs x 28)				

Continued on Page 266

variable	RTCM header (for RTCM19)	RTCM message type	Ulong	4	variable
		Base station ID	Ulong	4	
		Modified Z count where the Z count week number is the week number from subframe 1 of the ephemeris	Ulong	4	
		Sequence number	Ulong	4	
		Length of frame	Ulong	4	
		Base station health, see <i>REFSTATION on Page 250</i>	Ulong	4	
variable	freq	Frequency indicator where 0 = L1 2 = L2 (1 is reserved for future use)	Ulong	4	variable
	smooth	Smoothing interval, see <i>Table 70, RTCM1819 Smoothing Interval on Page 268</i>	Ulong	4	
	GNSS time	GNSS time of measurement (μ s)	Long	4	
	#obs	Number of observations with information to follow	Ulong	4	
variable	multi bit	Multiple message indicator	Ulong	4	variable
	code	Is code P Code? 0 = FALSE 1 = TRUE	Ulong	4	
	sat type	Satellite type 0 = GPS 1 = GLONASS	Ulong	4	
	prn	Satellite PRN number	Ulong	4	
	quality	Data quality indicator, see <i>Table 69, RTCM1819 Data Quality Indicator on Page 267</i>	Ulong	4	
	multipath	Multipath indicator, see <i>Table 71, RTCM1819 Multipath Indicator on Page 268</i>	Ulong	4	
	range	Pseudorange (2/100 m)	Ulong	Ulong	
variable...	Next RTCM19 observation offset = variable				
variable	xxxx	32-bit CRC (ASCII and Binary only)	Hex	4	variable
variable	[CR][LF]	Sentence terminator (ASCII only)	-	-	-

Recommended Input:

```
log rtcmdata1819a ontime 2
```

ASCII Example:

```
#RTCM1819A, COM1, 1, 73.5, FINESTEERING, 1117, 161114.000, 00100020, b077, 399;
0, 0, 4523, 0, 0, 6,
2, 0, 200000, 11,
1, 1, 0, 3, 0, 1, 324771431,
1, 1, 0, 15, 0, 1, 64534978,
1, 1, 0, 18, 0, 1, 198055064,
1, 1, 0, 21, 0, 1, 426607534,
1, 1, 0, 17, 0, 1, -101227879,
1, 1, 0, 6, 0, 7, -70480075,
1, 1, 0, 26, 0, 1, -205262773,
1, 1, 0, 23, 0, 1, 46251638,
1, 1, 0, 28, 0, 1, 167164502,
1, 1, 0, 31, 0, 1, 77539005,
1, 1, 0, 22, 0, 3, -19,
0, 0, 4523, 0, 0, 6,
2, 0, 200000, 11,
1, 1, 0, 3, 2, 3, 1114597101,
1, 1, 0, 15, 2, 3, 999274497,
1, 1, 0, 18, 2, 3, 1022282623,
1, 1, 0, 21, 2, 3, 1151773907,
1, 1, 0, 17, 2, 3, 1015290815,
1, 1, 0, 6, 2, 3, 1207662688,
1, 1, 0, 26, 2, 3, 1085620069,
1, 1, 0, 23, 2, 3, 1029707897,
1, 1, 0, 28, 2, 3, 1240811844,
1, 1, 0, 31, 2, 3, 1242647691,
1, 1, 0, 22, 4, 3, 1241415667*820e5a7b
```

Table 69: RTCM1819 Data Quality Indicator

Code	Pseudorange Error
0	≤ 0.020 m
1	≤ 0.030 m
2	≤ 0.045 m
3	≤ 0.066 m
4	≤ 0.099 m
5	≤ 0.148 m
6	≤ 0.220 m
7	≤ 0.329 m
8	≤ 0.491 m
9	≤ 0.732 m
10	≤ 1.092 m
11	≤ 1.629 m
12	≤ 2.430 m
13	≤ 3.625 m
14	≤ 5.409 m
15	> 5.409 m

Table 70: RTCM1819 Smoothing Interval

Code	Smoothing Interval (Minutes)
0	0 to 1
1	1 to 5
2	5 to 15
3	Undefined smoothing interval

Table 71: RTCM1819 Multipath Indicator

Code	Multipath Error
0	≤ 0.100 m
1	≤ 0.149 m
2	≤ 0.223 m
3	≤ 0.332 m
4	≤ 0.495 m
5	≤ 0.739 m
6	≤ 1.102 m
7	≤ 1.644 m
8	≤ 2.453 m
9	≤ 3.660 m
10	≤ 5.460 m
11	≤ 8.145 m
12	≤ 12.151 m
13	≤ 18.127 m
14	> 18.127 m
15	Undetermined multipath

3.4.70 RTCMDATA2021 Measurement Corrections RTK

See the chapter on *Message Formats* in *Volume 1* of this manual set for information on RTCM standard logs.

Message ID: 400

Log Type: Synch

Field #	Field type	Data Description	Format	Binary Bytes	Binary Offset
1	header	Log header	-	H	0
2	RTCM header (for RTCM20)	RTCM message type	Ulong	4	H
3		Base station ID	Ulong	4	H+4
4		Modified Z count where the Z count week number is the week number from subframe 1 of the ephemeris	Ulong	4	H+8
5		Sequence number	Ulong	4	H+12
6		Length of frame	Ulong	4	H+16
7		Base station health, see <i>REFSTATION</i> on Page 250	Ulong	4	H+20
8		freq	Frequency indicator 0 = L1 2 = L2	Ulong	4
9	Reserved		Ulong	4	H+28
10	GNSS time	Global Navigation Satellite System (GNSS) time of measurement (μ s)	Long	4	H+32
11	#obs	Number of observation with information to follow	Long	4	H+36
12	multi bit	Multiple message indicator	Ulong	4	H+40
13	code	Is code P Code? 0 = FALSE 1 = TRUE	Ulong	4	H+44
14	sat type	Satellite type 0 = GPS 1 = GLONASS	Ulong	4	H+48
15	prn	Satellite PRN number	Ulong	4	H+52
16	quality	Data quality indicator, see <i>Table 72, RTCM2021 Data Quality Indicator</i> on Page 272	Ulong	4	H+56
17	continuity	Cumulative loss of continuity indicator with a loss of lock counter	Ulong	4	H+60
18	IODE	Issue of ephemeris data	Ulong	4	H+64
19	phase	Carrier phase correction (1/256 cycles)	Long	4	H+68
20...	Next RTMC20 observation offset = H+40 + (#obs x 32)				

Continued on Page 270

variable	RTCM header (for RTCM21)	RTCM message type	Ulong	4	variable
		Base station ID	Ulong	4	
		Modified Z count where the Z count week number is the week number from subframe 1 of the ephemeris.	Ulong	4	
		Sequence number	Ulong	4	
		Length of frame	Ulong	4	
		Base station health, see <i>REFSTATION</i> on Page 250	Ulong	4	
variable	freq	Frequency indicator	Ulong	4	variable
	Reserved		Ulong	4	
	GNSS time	GNSS time of measurement	Long	4	
	#obs	Number of observations with information to follow	Ulong	4	
variable	rate scale	Pseudorange rate correction scale factor 0 = 0.002 1 = 0.032	Ulong	4	variable
	code	Is code P Code? 0 = FALSE 1 = TRUE	Ulong	4	
	sat type	Satellite type 0 = GPS 1 = GLONASS	Ulong	4	
	prn	Satellite PRN number	Ulong	4	
	corr scale	Pseudorange correction scale factor 0 = 0.02 1 = 0.32	Ulong	4	
	quality	Data quality indicator, see <i>Table 72, RTCM2021 Data Quality Indicator</i> on Page 272	Ulong	4	
	multipath	Multipath indicator, see <i>Table 73, RTCM2021 Multipath Indicator</i> on Page 272	Ulong	4	
	IODE	Issue of ephemeris data	Ulong	4	
	range corr	Pseudorange correction (scaled)	Long	4	
	range rate	Pseudorange range correction rate (scaled)	Long	4	
variable...	Next RTCM21 observation offset = variable				
variable	xxxx	32-bit CRC (ASCII and Binary only)	Hex	4	variable
variable	[CR][LF]	Sentence terminator (ASCII only)	-	-	-

Recommended Input:

log rtcmdata2021a ontime 10

ASCII Example:

```
#RTCMDATA2021A, COM1, 0, 72.0, FINESTEERING, 1117, 161400.000, 00100020, fc4d, 399;  
0, 0, 5000, 0, 0, 6,  
2, 0, 0, 10,  
0, 1, 0, 3, 0, 1, 43, -324,  
0, 1, 0, 15, 0, 1, 96, -812,  
0, 1, 0, 18, 0, 1, 1, 514,  
0, 1, 0, 21, 0, 1, 153, 997,  
0, 1, 0, 6, 0, 7, 88, -779,  
0, 1, 0, 26, 0, 1, 35, 39,  
0, 1, 0, 23, 0, 1, 167, 229,  
0, 1, 0, 28, 0, 1, 22, 1738,  
0, 1, 0, 31, 0, 1, 125, 5194,  
0, 1, 0, 22, 0, 4, 27, -102,  
0, 0, 5000, 0, 0, 6,  
2, 0, 0, 10,  
0, 1, 0, 3, 0, 0, 3, 43, -661, -9,  
0, 1, 0, 15, 0, 0, 3, 96, -479, -11,  
0, 1, 0, 18, 0, 0, 3, 1, -152, -8,  
0, 1, 0, 21, 0, 0, 3, 153, -933, -9,  
0, 1, 0, 6, 0, 0, 3, 88, -2151, -12,  
0, 1, 0, 26, 0, 0, 3, 35, -630, -8,  
0, 1, 0, 23, 0, 0, 3, 167, -259, -10,  
0, 1, 0, 28, 0, 0, 3, 22, -1503, -7,  
0, 1, 0, 31, 0, 0, 3, 125, -1905, -9,  
0, 1, 0, 22, 0, 0, 3, 27, -2281, -14*F3963d96
```

Table 72: RTCM2021 Data Quality Indicator

Code	Pseudorange Error
0	≤ 0.1 m
1	≤ 0.25 m
2	≤ 0.5 m
3	≤ 1.0 m
4	≤ 2.0 m
5	≤ 3.5 m
6	≤ 5 m
7	> 5

Table 73: RTCM2021 Multipath Indicator

Code	Multipath Error
0	≤ 0.1 m
1	≤ 0.25 m
2	≤ 0.5 m
3	≤ 1.0 m
4	≤ 2.5 m
5	≤ 5 m
6	> 5 m
7	Undetermined multipath

3.4.71 RTCMDATA22 Extended Base Station RTK

See the chapter on *Message Formats* in *Volume 1* of this manual set for information on RTCM standard logs.

Message ID: 401
Log Type: Synch

Field #	Field type	Data Description	Format	Binary Bytes	Binary Offset
1	header	Log header	-	H	0
2	RTCM header	RTCM message type	Ulong	4	H
3		Base station ID	Ulong	4	H+4
4		Modified Z count where the Z count week number is the week number from subframe 1 of the ephemeris.	Ulong	4	H+8
5		Sequence number	Ulong	4	H+12
6		Length of frame	Ulong	4	H+16
7		Base station health, see <i>REFSTATION</i> on Page 250	Ulong	4	H+20
8		L1 ECEF-X	L1 ECEF ΔX correction (1/256 cm)	Long	4
9	L1 ECEF-Y	L1 ECEF ΔY correction (1/256 cm)	Long	4	H+28
10	L1 ECEF-Z	L1 ECEF ΔZ correction (1/256 cm)	Long	4	H+32
11	Reserved		Ulong	4	H+36
12	height stat	No height flag where 0 = FALSE 1 = TRUE	Enum	4	H+40
13	phase center	Antenna L1 phase center height (1/256 cm)	Ulong	4	H+44
14	L2 ECEF-X	L1 ECEF ΔX correction (1/256 cm)	Long	4	H+48
15	L2 ECEF-Y	L1 ECEF ΔY correction (1/256 cm)	Long	4	H+52
16	L2 ECEF-Z	L1 ECEF ΔZ correction (1/256 cm)	Long	4	H+56
17	xxxx	32-bit CRC (ASCII and Binary only)	Hex	4	H+60
18	[CR][LF]	Sentence terminator (ASCII only)	-	-	-

Recommended Input:

```
log rtcmdata22a ontime 10
```

ASCII Example:

```
#RTCMDATA22A, COM1, 0, 70.0, FINESTEERING, 1117, 161590.000, 00100020, 990f, 399;  
1730644, 0, 5316, 2324476, 8451556, 6,  
61, -64, 120, 0, TRUE, 0, 0, 0, 0*b86ebf12
```

3.4.72 RTCMDATA59 Type 59N-0 NovAtel RT20 Differential RTK

See the chapter on *Message Formats* in *Volume 1* of this manual set for information on RTCM standard logs.

Message ID: 403

Log Type: Synch

Field #	Field type	Data Description	Format	Binary Bytes	Binary Offset
1	header	Log header	-	H	0
2	RTCM header	RTCM message type	Ulong	4	H
3		Base station ID	Ulong	4	H+4
4		Modified Z count where the Z count week number is the week number from subframe 1 of the ephemeris.	Ulong	4	H+8
5		Sequence number	Ulong	4	H+12
6		Length of frame	Ulong	4	H+16
7		Base station health, see <i>REFSTATION on Page 250</i>	Ulong	4	H+20
8	subtype	Message subtype	Char	4 ^a	H+24
9	min psr	Minimum pseudorange (m)	Long	4	H+28
10	time offset	Time difference between the Z-count time and the measurement time where Z-count time from subframe 1 of the ephemeris (0.1 seconds / lsb)	Long	4	H+32
10	Reserved		Ulong	4	H+36
11	#prn	Number of PRNs with information to follow	Ulong	4	H+40
12	prn	Satellite PRN number	Ulong	4	H+44
13	lock	Lock time: 0 = <20 seconds 1 = 20-40 seconds 2 = 40-80 seconds 3 = >80 seconds	Ulong	4	H+48
14	psr	Pseudorange correction (1/10 m)	Ulong	4	H+52
15	adr	Accumulated Doppler Range (ADR) correction (1/1000 m)	Long	4	H+56
16...	Next PRN offset = H+44 + (#prns x 16)				
variable	xxxx	32-bit CRC (ASCII and Binary only)	Hex	4	variable
variable	[CR][LF]	Sentence terminator (ASCII only)	-	-	-

- a. In the binary log case an additional 3 bytes of padding are added to maintain 4 byte alignment

Recommended Input:

log rtcmdata59a ontime 10

ASCII Example:

```
#RTCMDATA59A, COM1, 0, 71.5, FINESTEERING, 1117, 323592.000, 00140000, 3df8, 337;  
67108864, 0, 5320, 67272710, 0, 6,  
78, 20341249, 0, 0, 10,  
15, 2, 36613566, -153,  
30, 2, 24667890, -209,  
17, 3, 21548029, -138,  
6, 3, 6, -68,  
23, 3, 43118232, -225,  
5, 0, 45608604, -118,  
24, 3, 31489783, -218,  
10, 3, 5398457, 55,  
22, 3, 35679766, 33,  
26, 2, 42925557, -101*203b6b3d
```

3.4.73 RTCMV3 RTCMV3 Standard Logs RTK

RTCM1001 L1-ONLY GPS RTK OBSERVABLES

Message ID: 772

RTCM1002 EXTENDED L1-ONLY GPS RTK OBSERVABLES

Message ID: 774

RTCM1003 L1 AND L2 GPS RTK OBSERVABLES

MESSAGE ID: 776

RTCM1004 EXTENDED L1AND L2 GPS RTK OBSERVABLES

Message ID: 770

RTCM1005 STATIONARY RTK BASE STATION ANTENNA REFERENCE POINT (ARP)

Message ID: 765

RTCM1006 STATIONARY RTK BASE STATION ARP WITH ANTENNA HEIGHT

Message ID: 768

RTCM SC-104 Version 3.0 is a more efficient alternative to the documents entitled "RTCM Recommended Standards for Differential Navstar GPS Service, Version 2.x". Version 3.0, consists primarily of messages designed to support real-time kinematic (RTK) operations. The reason for this emphasis is that RTK operation involves broadcasting a lot of information, and thus benefits the most from a more efficient data format.

The RTCM SC-104 standards have been adopted by NovAtel for implementation into the receiver. The receiver can easily be integrated into positioning systems around the globe because it is capable of utilizing RTCM Version 3.0 formats. Refer to the chapter on *Message Formats* in *Volume 1* of this manual set for more information on RTCMV3 standard logs.

-
- ☒ 1. At the base station, choose to send either an RTCM1005 or RTCM1006 message to the rover station. Then select one of the observable messages (RTCM1001, RTCM1002, RTCM1003 or RTCM1004) to send from the base.
 - 2. The RTCM messages can be logged with an A or B suffix for an ASCII or Binary output with a NovAtel header followed by Hex or Binary raw data respectively.
-

Example Input:

```
interfacemode com2 none RTCMV3
fix position 51.1136 -114.0435 1059.4
log com2 rtc1005 ontime 3
log com2 rtc1002 ontime 10
```

3.4.74 RTCMDATA1001 L1-Only GPS RTK Observables RTK

This log is available at the base station. Refer to the chapter on *Message Formats* in *Volume 1* of this manual set for information on RTCMV3 logs.

Message ID: 784
Log Type: Synch

Field #	Field type	Data Description	Format	Binary Bytes	Binary Offset
1	header	Log header	-	H	0
2	RTCMV3 observations header	Message number	Ushort	2	H
3		Base station ID	Ushort	2	H+2
4		GPS epoch time in milliseconds from the beginning of the GPS week, which begins at midnight GMT on Saturday night/Sunday morning, measured in GPS time (as opposed to UTC).	Ulong	4	H+4
5		GNSS message flag: 0 = No further GNSS observables referenced to the same epoch time. The receiver begins to process data immediately after decoding the message. 1 = The next message contains observables from another GNSS source referenced to the same epoch time.	Uchar	1	H+8
6		Number of GPS satellite signals processed (the number of satellites in the message and not necessarily equal to the number of satellites visible to the base station).	Uchar	1	H+9
7		Smoothing indicator 0 = Divergence-free smoothing not used 1 = Divergence-free smoothing used	Uchar	1	H+10
8		Smoothing interval, see <i>Table 74 on Page 278</i> . This is the integration period over which reference station pseudorange code phase measurements are averaged using carrier phase information. Divergence-free smoothing may be continuous over the entire period that the satellite is visible.	Uchar	1	H+11
9		#prns	Number of PRNs with information to follow	Ulong	4
10	prn#	Satellite PRN number	Uchar	1	H+16
11	code-ind	GPS L1 code indicator 0 = C/A code 1 = P(Y) code direct	Uchar	1	H+17
12	psr	GPS L1 pseudorange (m)	Ulong	4	H+18
13	phase-pseudo	GPS L1 (phaserange - pseudorange) Range: -262.1435 to +262.1435 m	Long	4	H+22
14	locktime-ind	GPS L1 lock time indicator, see <i>Table 75 on Page 278</i>	Uchar	2 ^a	H+26
15...	Next PRN offset = H+16 + (#prns x 12)				
variable	xxxx	32-bit CRC (ASCII and Binary only)	Hex	4	variable
variable	[CR][LF]	Sentence terminator (ASCII only)	-	-	-

a. In the binary log case an additional byte of padding is added to maintain 4 byte alignment

Table 74: Carrier Smoothing Interval of Code Phase

Indicator		Smoothing Interval
ASCII	Binary	
0	000	No smoothing
1	001	< 30 s
2	010	30-60 s
3	011	1-2 min.
4	100	2-4 min.
5	101	4-8 min.
6	110	>8 min.
7	111	Unlimited smoothing interval

Table 75: Lock Time Indicator

Indicator (i) ^a	Minimum Lock Time (s)	Range of Indicated Lock Times
0-23	i	$0 \leq \text{lock time} < 24$
24-47	$i \cdot 2 - 24$	$24 \leq \text{lock time} < 72$
48-71	$i \cdot 4 - 120$	$72 \leq \text{lock time} < 168$
72-95	$i \cdot 8 - 408$	$168 \leq \text{lock time} < 360$
96-119	$i \cdot 16 - 1176$	$360 \leq \text{lock time} < 744$
120-126	$i \cdot 32 - 3096$	$744 \leq \text{lock time} < 937$
127	---	$\text{lock time} \geq 937$

- a. Determining Loss of Lock: In normal operation, a cycle slip is evident when the Minimum Lock Time (s) has decreased in value. For long time gaps between messages, such as from a radio outage, extra steps should be taken on the rover to safeguard against missed cycle slips.

Recommended Input:

log rtcmdata1001a ontime 10 3

ASCII Example:

```
#RTCMDATA1001A, COM1, 0, 82.0, FINESTEERING, 1317, 239228.000, 00180040, c279, 1855;  
0, 0, 239228000, 0, 8, 0, 0, 8, 21, 0, 14513926, 8707, 127, 2, 0, 3705361, 5040, 127, 16, 0,  
7573721, 3555, 124, 29, 0, 5573605, -11078, 127, 26, 0, 2996771, -17399, 99, 6, 0, 9341652,  
-329, 127, 10, 0, 13274623, 2408, 127, 30, 0, 3355111, 18860, 127*ec698c2a
```

3.4.75 RTCMDATA1002 Extended L1-Only GPS RTK Observables RTK

This log is available at the base station. Refer to the chapter on *Message Formats* in *Volume 1* of this manual set for information on RTCMV3 logs.

Message ID: 785

Log Type: Synch

Field #	Field type	Data Description	Format	Binary Bytes	Binary Offset
1	header	Log header	-	H	0
2	RTCMV3 observations header, see the RTCMDATA1001 log on <i>Page 277</i> for details	Message number	Ushort	2	H
3		Base station ID	Ushort	2	H+2
4		GPS epoch time (ms)	Ulong	4	H+4
5		GNSS message flag	Uchar	1	H+8
6		Number of GPS satellite signals processed (0-31)	Uchar	1	H+9
7		Smoothing indicator	Uchar	1	H+10
8		Smoothing interval, see <i>Table 74</i> on <i>Page 278</i> .	Uchar	1	H+11
9		#prns	Number of PRNs with information to follow	Ulong	4
10	prn#	Satellite PRN number	Uchar	1	H+16
11	code-ind	GPS L1 code indicator 0 = C/A code 1 = P(Y) code direct	Uchar	1	H+17
12	psr	GPS L1 pseudorange (m)	Ulong	4	H+18
13	phase-pseudo	GPS L1 (phaserange - pseudorange) Range: -262.1435 to +262.1435 m	Long	4	H+22
14	locktime-ind	GPS L1 lock time indicator, see <i>Table 75</i> on <i>Page 278</i>	Uchar	1	H+26
15	amb	GPS L1 PSR modulus ambiguity (m). The integer number of full pseudorange modulus divisions (299,792.458 m) of the raw L1 pseudorange measurement.	Uchar	1	H+27
16	CNR	GPS L1 carrier-to-noise ratio (dBHz). The reference station's estimate of the satellite's signal. A value of 0 indicates that the CNR measurement is not computed.	Uchar	4 ^a	H+28
17...	Next PRN offset = H+16 + (#prns x 16)				
variable	xxxx	32-bit CRC (ASCII and Binary only)	Hex	4	variable
variable	[CR][LF]	Sentence terminator (ASCII only)	-	-	-

a. In the binary log case an additional 3 bytes of padding are added to maintain 4 byte alignment

Recommended Input:

log rtcmdata1002a ontime 7

ASCII Example:

```
#RTCMDATA1002A, COM1, 0, 79.0, FINESTEERING, 1317, 239318.000, 00180040, adb2, 1855;  
0, 0, 239318000, 0, 9, 0, 0, 9, 21, 0, 12261319, -9236, 127, 0, 202,  
2, 0, 6623657, 4517, 127, 0, 171, 16, 0, 5632627, 1876, 127, 0, 179,  
29, 0, 3064427, -10154, 127, 0, 177, 26, 0, 14721908, -21776, 105, 0, 164,  
6, 0, 9384778, 1113, 127, 0, 205, 18, 0, 9594701, -1176, 27, 0, 184,  
10, 0, 14876991, 8629, 127, 0, 202, 30, 0, 6417059, 20243, 127, 0, 195*e7d3c54d
```

3.4.76 RTCMDATA1003 L1/L2 GPS RTK Observables RTK

This log is available at the base station. Refer to the chapter on *Message Formats* in *Volume 1* of this manual set for information on RTCMV3 logs.

Message ID: 786

Log Type: Synch

Field #	Field type	Data Description	Format	Binary Bytes	Binary Offset
1	header	Log header	-	H	0
2	RTCMV3 observations header, see the RTCMDATA1001 log on <i>Page 277</i> for details	Message number	Ushort	2	H
3		Base station ID	Ushort	2	H+2
4		GPS epoch time (ms)	Ulong	4	H+4
5		GNSS message flag	Uchar	1	H+8
6		Number of GPS satellite signals processed (0-31)	Uchar	1	H+9
7		Smoothing indicator	Uchar	1	H+10
8		Smoothing interval, see <i>Table 74</i> on <i>Page 278</i> .	Uchar	1	H+11
9		#prns	Number of PRNs with information to follow	Ulong	4
10	prn#	Satellite PRN number	Uchar	1	H+16
11	L1code-ind	GPS L1 code indicator 0 = C/A code 1 = P(Y) code direct	Uchar	1	H+17
12	L1psr	GPS L1 pseudorange (m)	Ulong	4	H+18
13	L1 phase-pseudo	GPS L1 (phaserange - pseudorange) Range: -262.1435 to +262.1435 m	Long	4	H+22
14	L1locktime-ind	GPS L1 lock time indicator, see <i>Table 75</i> on <i>Page 278</i>	Uchar	1	H+26
15	L2code-ind	GPS L2 code indicator 0 = C/A or L2C code 1 = P(Y) code direct 2 = P(Y) code cross-correlated 3 = Correlated P/Y	Uchar	1	H+27
16	L1L2psrdiff	GPS L2-L1 pseudorange difference (m)	Short	2	H+28
17	L2phase-L1pseudo	GPS L2 phaserange - L1 pseudorange Range: -262.1435 m to +262.1435 m	Long	4	H+30
18	L1L2 locktime-ind	GPS L2 lock time indicator, see <i>Table 75</i> on <i>Page 278</i>	Uchar	2 ^a	H+34
19...	Next PRN offset = H+16 + (#prns x 20)				
variable	xxxx	32-bit CRC (ASCII and Binary only)	Hex	4	variable
variable	[CR][LF]	Sentence terminator (ASCII only)	-	-	-

a. In the binary log case an additional byte of padding is added to maintain 4 byte alignment

Recommended Input:

log rtcmdata1003a ontime 7

ASCII Example:

```
#RTCMDATA1003A, COM1, 0, 79.0, FINESTEERING, 1317, 239386.000, 00180040, a38c, 1855;  
0, 0, 239386000, 0, 9, 0, 0, 9,  
21, 0, 10569576, -8901, 127, 0, -176, -7752, 127,  
2, 0, 8831714, 3717, 127, 0, -163, 7068, 127,  
16, 0, 4189573, -1118, 127, 0, -108, -1273, 127,  
29, 0, 1181151, -10116, 127, 0, -61, -11354, 127,  
26, 0, 12256552, -15107, 109, 0, 24, -18232, 109,  
6, 0, 9442835, 1961, 127, 0, -116, 2536, 127,  
18, 0, 7145333, -3326, 54, 0, -17, -304, 54,  
10, 0, 1125215, 13933, 127, 0, -148, 12353, 127,  
30, 0, 8737848, 20418, 127, 0, -48, 19592, 127*2286a5ab
```

3.4.77 RTCMDATA1004 Expanded L1/L2 GPS RTK Observables RTK

This log is available at the base station. Refer also to *Message Formats* in *Volume 1* of this manual set.

Message ID: 787

Log Type: Synch

Field #	Field type	Data Description	Format	Binary Bytes	Binary Offset
1	header	Log header	-	H	0
2	RTCMV3 observations header, see the RTCMDATA1001 log on <i>Page 277</i> for details	Message number	Ushort	2	H
3		Base station ID	Ushort	2	H+2
4		GPS epoch time (ms)	Ulong	4	H+4
5		GNSS message flag	Uchar	1	H+8
6		Number of GPS satellite signals processed (0-31)	Uchar	1	H+9
7		Smoothing indicator	Uchar	1	H+10
8		Smoothing interval, see <i>Table 74</i> on <i>Page 278</i> .	Uchar	1	H+11
9		#prns	Number of PRNs with information to follow	Ulong	4
10	prn#	Satellite PRN number	Uchar	1	H+16
11	L1code-ind	GPS L1 code indicator 0 = C/A code 1 = P(Y) code	Uchar	1	H+17
12	L1psr	GPS L1 pseudorange (m)	Ulong	4	H+18
13	L1 phase-pseudo	GPS L1 (phaserange - pseudorange) Range: -262.1435 to +262.1435 m	Long	4	H+22
14	L1lcktm-ind	GPS L1 lock time indicator, see <i>Table 75</i> on <i>Page 278</i>	Uchar	1	H+26
15	L1amb	GPS L1 PSR modulus ambiguity (m). The integer number of full pseudorange modulus divisions (299,792.458 m) of the raw L1 pseudorange.	Uchar	1	H+27
16	L1CNR	GPS L1 carrier-to-noise ratio (dBHz). The reference station's estimate of the satellite's signal. A value of 0 indicates that the CNR measurement is not computed.	Uchar	1	H+28
17	L2code-ind	GPS L2 code indicator: 0 = C/A or L2C code 1 = P(Y) code direct 2 = P(Y) code cross-correlated 3 = Correlated P(Y)	Uchar	1	H+29
18	L1L2psrdiff	GPS L2-L1 pseudorange difference (m)	Short	4 ^a	H+30
19	L2phase-L1pseudo	GPS L2 phaserange - L1 pseudorange Range: -262.1435 m to +262.1435 m	Long	4	H+34
20	L2lcktm-ind	GPS L2 lock time indicator, see <i>Table 75</i> on <i>Page 278</i>	Uchar	1	H+38
21	L2CNR	GPS L2 carrier-to-noise ratio (dBHz). The reference station's estimate of the satellite's signal. A value of 0 indicates that the CNR measurement is not computed.	Uchar	1	H+39
22...	Next PRN offset = H+16 + (#prns x 24)				
variable	xxxx	32-bit CRC (ASCII and Binary only)	Hex	4	variable
variable	[CR][LF]	Sentence terminator (ASCII only)	-	-	-

a. In the binary log case an additional 2 bytes of padding are added to maintain 4 byte alignment

Recommended Input:

log rtcmdata1004a ontime 7

ASCII Example:

```
#RTCMDATA1004A, COM1, 0, 83.5, FINESTEERING, 1317, 238497.000, 00180040, 5500, 1855;  
0, 0, 238497000, 0, 7, 0, 0, 7,  
21, 0, 3492634, 1536, 98, 0, 202, 0, -169, 1904, 96, 175,  
2, 0, 10314064, -3500, 99, 0, 195, 0, -192, -1385, 96, 165,  
16, 0, 9713480, 7187, 65, 0, 164, 0, -80, 6159, 65, 148,  
29, 0, 11686252, 1601, 95, 0, 163, 0, -24, 932, 94, 164,  
6, 0, 10511647, 3261, 99, 0, 206, 0, -115, 3375, 96, 188,  
10, 0, 1964375, 2688, 99, 0, 200, 0, -120, 2779, 96, 178,  
30, 0, 9085068, 4078, 98, 0, 190, 0, -50, 2990, 96, 167*f91c8c6d
```

3.4.78 RTCMDATA1005 Base Station Antenna Reference Point (ARP) RTK

This log is available at the base station. Refer to the chapter on *Message Formats* in *Volume 1* of this manual set for information on RTCMV3 logs.

Message ID: 788

Log Type: Synch

Field #	Field type	Data Description	Format	Binary Bytes	Binary Offset
1	header	Log header	-	H	0
2	msg#	Message number	Ushort	2	H
3	ID	Base station ID	Ushort	2	H+2
4	Reserved		Uchar	1	H+4
5	GPSind	GPS indicator 0 = No GPS service supported 1 = GPS service supported	Uchar	1	H+5
6	GLOind	GLONASS indicator 0 = No GLONASS service supported 1 = GLONASS service supported	Uchar	1	H+6
7	GALind	Galileo indicator 0 = No Galileo service supported 1 = Galileo service supported	Uchar	1	H+7
8	Reserved		Uchar	1	H+8
9	ECEF-X	Base station ECEF X-coordinate (1/10000 m)	Double	8	H+9
10	Reserved		Uchar	1	H+17
11	ECEF-Y	Base station ECEF Y-coordinate (1/10000 m)	Double	8	H+18
12	Reserved		Uchar	2 ^a	H+26
13	ECEF-Z	Base station ECEF Z-coordinate (1/10000 m)	Double	8	H+28
14	xxxx	32-bit CRC (ASCII and Binary only)	Hex	4	H+36
15	[CR][LF]	Sentence terminator (ASCII only)	-	-	-

a. In the binary log case an additional byte of padding is added to maintain 4 byte alignment

Recommended Input:

```
log rtcmdata1005a ontime 3
```

ASCII Example:

```
#RTCMDATA1005A,COM1,0,84.5,FINESTEERING,1317,238322.885,00180040,0961,1855;  
0,0,0,1,0,0,0,-16349783637,0,-36646792121,0,49422987955*7dbd6160
```

3.4.79 RTCMDATA1006 Base Station ARP with Antenna Height RTK

This log is available at the base station. Refer to the chapter on *Message Formats* in *Volume 1* of this manual set for information on RTCMV3 logs.

Message ID: 789

Log Type: Synch

Field #	Field type	Data Description	Format	Binary Bytes	Binary Offset
1	header	Log header	-	H	0
2	msg#	Message number	Ushort	2	H
3	ID	Base station ID	Ushort	2	H+2
4	Reserved		Uchar	1	H+4
5	GPSind	GPS indicator 0 = No GPS service supported 1 = GPS service supported	Uchar	1	H+5
6	GLOind	GLONASS indicator 0 = No GLONASS service supported 1 = GLONASS service supported	Uchar	1	H+6
7	GALind	Galileo indicator 0 = No Galileo service supported 1 = Galileo service supported	Uchar	1	H+7
8	Reserved		Uchar	1	H+8
9	ECEF-X	Base station ECEF X-coordinate (1/10000 m)	Double	8	H+9
10	Reserved		Uchar	1	H+17
11	ECEF-Y	Base station ECEF Y-coordinate (1/10000 m)	Double	8	H+18
12	Reserved		Uchar	2 ^a	H+26
13	ECEF-Z	Base station ECEF Z-coordinate (1/10000 m)	Double	8	H+28
14	anthgt	Antenna height	Ushort	4 ^b	H+36
15	xxxx	32-bit CRC (ASCII and Binary only)	Hex	4	H+40
16	[CR][LF]	Sentence terminator (ASCII only)	-	-	-

- In the binary log case an additional byte of padding is added to maintain 4 byte alignment
- In the binary log case 2 additional bytes of padding are added to maintain 4 byte alignment

Recommended Input:

```
log rtcmdata1006a ontime 3
```

ASCII Example:

```
#RTCMDATA1006A, COM1, 0, 80.5, FINESTEERING, 1317, 239459.744, 00180040, 7583, 1855  
;0, 0, 0, 1, 0, 0, 0, -16349783637, 0, -36646792121, 0, 49422987955, 0*5a466fb5
```

3.4.80 RTKDATA RTK Solution Parameters RTK

This is the “RTK output” log, and it contains miscellaneous information regarding the RTK solution. It is based on the matched update. Note that the length of the log messages will vary depending on the number of common satellites (on both rover and base stations) in the solution, a quantity represented by #sv in the field numbers.

See also the BESTPOS log (the best available position computed by one receiver) and the MATCHEDPOS log (positions that have been computed from time matched base and rover observations), on *Pages 161 and 214* respectively.

See *Figure 8, Page 170* for a definition of the ECEF coordinates

Message ID: 215

Log Type: Asynch

Field #	Field type	Data Description	Format	Binary Bytes	Binary Offset
1	header	Log header		H	0
2	sol status	Solution status (see <i>Table 48, Solution Status on Page 163</i>)	Enum	4	H
3	pos type	Position type (see <i>Table 47, Position or Velocity Type on Page 162</i>)	Enum	4	H+4
4	rtk info	RTK information (see <i>Table 78, RTK Information on Page 290</i>)	Ulong	4	H+8
5	#obs	Number of observations tracked	Uchar	1	H+12
6	#GPSL1	Number of GPS L1 ranges used in computation	Uchar	1	H+13
7	#L1	Number of GPS L1 ranges above the RTK mask angle	Uchar	1	H+14
8	#L2	Number of GPS L2 ranges above the RTK mask angle	Uchar	1	H+15
9	Reserved		Uchar	1	H+16
10			Uchar	1	H+17
11			Uchar	1	H+18
12			Uchar	1	H+19
13	search stat	Searcher status (see <i>Table 76, Searcher Type on Page 290</i>)	Enum	4	H+20
14	# lane	Number of possible lane combinations	Ulong	4	H+24
15-23	[C]	The $C_{xx}, C_{xy}, C_{xz}, C_{yx}, C_{yy}, C_{yz}, C_{zx}, C_{zy}$ and C_{zz} components in (meters) ² , of the ECEF position covariance matrix (3x3)	Float	36	H+28
24	Δx	Float solution baseline in ECEF - x	Double	8	H+64
25	Δy	Float solution baseline in ECEF - y	Double	8	H+72
26	Δz	Float solution baseline in ECEF - z	Double	8	H+80
27	$x \sigma$	Standard deviation of float solution baseline - x (m)	Float	4	H+88
28	$y \sigma$	Standard deviation of float solution baseline - y (m)	Float	4	H+92
29	$z \sigma$	Standard deviation of float solution baseline - z (m)	Float	4	H+96
30	ref PRN	Base PRN	Ulong	4	H+100
31	# SV	Number of SVs to follow.	Long	4	H+104
32	PRN	Satellite PRN number of range measurement	Ulong	4	H+108
33	amb	Ambiguity type (see <i>Table 77, Ambiguity Type on Page 290</i>)	Enum	4	H+112
34	res	Residual (m)	Float	4	H+116

Continued on Page 289

Field #	Field type	Data Description	Format	Binary Bytes	Binary Offset
35...	Next SV offset = H + 108 + (obs x 12)				
variable	xxxx	32-bit CRC (ASCII and Binary only)	Hex	4	H+108+(12x obs)
variable	[CR][LF]	Sentence terminator (ASCII only)	-	-	-

Recommended Input:

log rtkdataa onchanged

-
- Asynchronous logs should only be logged ONCHANGED. Otherwise, the most current data is not output when it is available. This is especially true of the ONTIME trigger, which may cause inaccurate time tags to result.
-

ASCII Example:

```
#RTKDATAA, COM1, 0, 67.5, FINESTEERING, 1263, 249934.000, 00000000, f013, 1522;
SOL_COMPUTED, NARROW_INT, 00000003, 10, 8, 8, 8, 0, 0, 0, 0, HANDOFF_COMPLETE, 1,
2.9794e-05, 3.4515e-05, -3.6738e-05,
3.4515e-05, 1.0044e-04, -8.0896e-05,
-3.6738e-05, -8.0896e-05, 2.4138e-04,
-3.2072, 3.0497, 1.2114, 0.0184, 0.0332, 0.0378, 29,
7,
17, NARROW_INT, 0.000034189,
10, NARROW_INT, 0.002642911,
21, NARROW_INT, -0.000157104,
16, NARROW_INT, 0.002812332,
26, NARROW_INT, 0.000783464,
18, NARROW_INT, 0.003042223,
15, NARROW_INT, -0.001087773*a985c950
```

Table 76: Searcher Type

Searcher Type (binary)	Searcher Type (ASCII)	Description
0	NONE_REQUESTED	No search requested
1	BUFFERING_MEASUREMENTS	Buffering measurements
2	SEARCHING	Currently searching
3	COMPLETE	Searcher made decision
4	HANDOFF_COMPLETE	Hand off to L1 and L2 complete

Table 77: Ambiguity Type

Ambiguity Type (binary)	Ambiguity Type (ASCII)	Description
0	UNDEFINED	Undefined ambiguity
1	L1_FLOAT	Floating L1 ambiguity
2	IONOFREE_FLOAT	Floating ionospheric-free ambiguity
3	NARROW_FLOAT	Floating narrow-lane ambiguity
4	NLF_FROM_WL1	Floating narrow-lane ambiguity derived from integer wide-lane ambiguity
5	L1_INT	Integer L1 ambiguity
6	WIDE_INT	Integer wide-lane ambiguity
7	NARROW_INT	Integer narrow-lane ambiguity
8	IONOFREE_DISCRETE	Discrete ionospheric-free ambiguity

Table 78: RTK Information

Bit #	Mask	Description	Bit = 0	Bit = 1
0	0x00000001	RTK dynamics	Static	Dynamic
1	0x00000002	RTK dynamics mode	Auto	Forced
2	0x00000004	Severe differential ionosphere detected	No	Yes
3-31	0xFFFFFFFF8	Reserved		

3.4.81 RTKPOS RTK Low Latency Position Data RTK

This log contains the low latency RTK position computed by the receiver, along with two status flags. In addition, it reports other status indicators, including differential age, which is useful in predicting anomalous behavior brought about by outages in differential corrections. This log is recommended for kinematic operation. Better accuracy can be obtained in static operation with the MATCHEDPOS log.

With the system operating in an RTK mode, this log will reflect if the solution is a good RTK low latency solution (from extrapolated base station measurements) or invalid. A valid RTK low latency solution will be computed for up to 60 seconds after reception of the last base station observation. The degradation in accuracy, due to differential age, is reflected in the standard deviation fields, and is summarized in the *GPS Overview* section of the *GPS+ Reference Manual* available on our website at <http://www.novatel.com/support/docupdates.htm>. See also the DGPSTIMEOUT command on Page 70.

Message ID: 141
Log Type: Synch

Field #	Field type	Data Description	Format	Binary Bytes	Binary Offset
1	header	Log header		H	0
2	sol status	Solution status (see Table 48, <i>Solution Status</i> on Page 163)	Enum	4	H
3	pos type	Position type (see Table 47, <i>Position or Velocity Type</i> on Page 162)	Enum	4	H+4
4	lat	Latitude	Double	8	H+8
5	lon	Longitude	Double	8	H+16
6	hgt	Height above mean sea level	Double	8	H+24
7	undulation	Undulation - the relationship between the geoid and the WGS84 ellipsoid (m) ^a	Float	4	H+32
8	datum id#	Datum ID number (see Chapter 2, Table 20, <i>Datum Transformation Parameters</i> on Page 65)	Enum	4	H+36
9	lat σ	Latitude standard deviation	Float	4	H+40
10	lon σ	Longitude standard deviation	Float	4	H+44
11	hgt σ	Height standard deviation	Float	4	H+48
12	stn id	Base station ID	Char[4]	4	H+52
13	diff_age	Differential age in seconds	Float	4	H+56
14	sol_age	Solution age in seconds	Float	4	H+60
15	#obs	Number of observations tracked	Uchar	1	H+64
16	#GPSL1	Number of GPS L1 ranges used in computation	Uchar	1	H+65
17	#L1	Number of GPS L1 ranges above the RTK mask angle	Uchar	1	H+66
18	#L2	Number of GPS L2 ranges above the RTK mask angle	Uchar	1	H+67
19	Reserved		Uchar	1	H+68
20			Uchar	1	H+69
21			Uchar	1	H+70
22			Uchar	1	H+71
23	xxxx	32-bit CRC (ASCII and Binary only)	Hex	4	H+72
24	[CR][LF]	Sentence terminator (ASCII only)	-	-	-

-
- a. When using a datum other than WGS84, the undulation value also includes the vertical shift due to differences between the datum in use and WGS84

Recommended Input:

log rtkposa ontime 1

ASCII Example:

```
#RTKPOSA,COM1,0,61.0,FINESTEERING,1263,250192.000,00000000,7e24,1522;  
SOL_COMPUTED,NARROW_INT,51.11633811000,-114.03839554959,1048.2207,  
-16.2711,WGS84,0.0125,0.0057,0.0111,"AAAA",2.000,0.000,11,  
8,8,8,0,0,0,0*c427e517
```

3.4.82 RTKVEL RTK Velocity RTK

This log contains the RTK velocity information computed by the receiver. In addition, it reports a velocity status indicator, which is useful in indicating whether or not the corresponding data is valid and differential age, which is useful in predicting anomalous behavior brought about by outages in differential corrections. The velocity measurements sometimes have a latency associated with them. The time of validity is the time tag in the log minus the latency value. See also the table footnote for velocity logs on *Page 142*.

With the system operating in an RTK mode, this log will reflect if the solution is a good RTK Low Latency solution (from extrapolated base station measurements) or invalid. A valid RTK Low Latency solution will be computed for up to 60 seconds after reception of the last base station observation. The degradation in accuracy due to differential age is reflected in the standard deviation fields, and is summarized in the *GPS Overview* section of the *GPS+ Reference Manual* available on our website at <http://www.novatel.com/support/docupdates.htm>. See also the DGPSTIMEOUT command on *Page 70*.

The velocity is computed from consecutive RTK low latency updates. As such, it is an average velocity based on the time difference between successive position computations and not an instantaneous velocity at the RTKVEL time tag. The velocity latency to be subtracted from the time tag will normally be 1/2 the time between filter updates. Under default operation, the RTK low latency filter is updated at a rate of 2 Hz. This translates into a velocity latency of 0.25 seconds. The latency can be reduced by increasing the update rate of the RTK low latency filter by requesting the BESTVEL, RTKVEL, BESTPOS or RTKPOS messages at a rate higher than 2 Hz. For example, a logging rate of 10 Hz would reduce the velocity latency to 0.005 seconds. For integration purposes, the velocity latency should be applied to the record time tag.

Message ID: 216

Log Type: Synch

Field #	Field type	Data Description	Format	Binary Bytes	Binary Offset
1	header	Log header		H	0
2	sol status	Solution status, see <i>Table 48, Solution Status on Page 163</i>	Enum	4	H
3	vel type	Velocity type, see <i>Table 47, Position or Velocity Type on Page 162</i>	Enum	4	H+4
4	latency	A measure of the latency in the velocity time tag in seconds. It should be subtracted from the time to give improved results.	Float	4	H+8
5	age	Differential age in seconds	Float	4	H+12
6	hor spd	Horizontal speed over ground, in meters per second	Double	8	H+16
7	trk gnd	Actual direction of motion over ground (track over ground) with respect to True North, in degrees	Double	8	H+24
8	vert spd	Vertical speed, in meters per second, where positive values indicate increasing altitude (up) and negative values indicate decreasing altitude (down)	Double	8	H+32
9	Reserved		Float	4	H+40
10	xxxx	32-bit CRC (ASCII and Binary only)	Hex	4	H+44
11	[CR][LF]	Sentence terminator (ASCII only)	-	-	-

Recommended Input:

```
log rtkvela ontime 1
```

ASCII Example:

```
#RTKVELA, COM1, 0, 69.5, FINESTEERING, 1263, 250259.000, 00000000, 71e2, 1522;  
SOL_COMPUTED, NARROW_INT, 0.250, 1.000, 0.0050, 84.774070, 0.0101, 0.0*bfa52ee6
```

3.4.83 RTKXYZ RTK Cartesian Position and Velocity RTK

This log contains the receiver's low latency position and velocity in ECEF coordinates. The position and velocity status field's indicate whether or not the corresponding data is valid. See *Figure 8, Page 170* for a definition of the ECEF coordinates.

The velocity measurements sometimes have a latency associated with them. The time of validity is the time tag in the log minus the latency value.

With the system operating in an RTK mode, this log will reflect if the solution is a good RTK Low Latency solution (from extrapolated base station measurements) or invalid. A valid RTK Low Latency solution will be computed for up to 60 seconds after reception of the last base station observation. The degradation in accuracy due to differential age is reflected in the standard deviation fields, and is summarized in the *GPS Overview* section of the *GPS+ Reference Manual* available on our website at <http://www.novatel.com/support/docupdates.htm>. See also the DGPSTIMEOUT command on *Page 70*.

The velocity is computed from consecutive RTK low latency updates. As such, it is an average velocity based on the time difference between successive position computations and not an instantaneous velocity at the RTKVEL time tag. The velocity latency to be subtracted from the time tag will normally be 1/2 the time between filter updates. Under default operation, the RTK low latency filter is updated at a rate of 2 Hz. This translates into a velocity latency of 0.25 seconds. The latency can be reduced by increasing the update rate of the RTK low latency filter by requesting the BESTXYZ message at a rate higher than 2 Hz. For example, a logging rate of 10 Hz would reduce the velocity latency to 0.005 seconds. For integration purposes, the velocity latency should be applied to the record time tag

See also the BESTXYZ and MATCHEDXYZ logs, on *Pages 168 and 219* respectively.

Message ID: 244
Log Type: Synch

Field #	Field type	Data Description	Format	Binary Bytes	Binary Offset
1	header	Log header		H	0
2	P-sol status	Solution status, see <i>Table 48, Solution Status on Page 163</i>	Enum	4	H
3	pos type	Position type, see <i>Table 47, Position or Velocity Type on Page 162</i>	Enum	4	H+4
4	P-X	Position X-coordinate (m)	Double	8	H+8
5	P-Y	Position Y-coordinate (m)	Double	8	H+16
6	P-Z	Position Z-coordinate (m)	Double	8	H+24
7	P-X σ	Standard deviation of P-X (m)	Float	4	H+32
8	P-Y σ	Standard deviation of P-Y (m)	Float	4	H+36
9	P-Z σ	Standard deviation of P-Z (m)	Float	4	H+40
10	V-sol status	Solution status, see <i>Table 48, Solution Status on Page 163</i>	Enum	4	H+44
11	vel type	Velocity type, see <i>Table 47 on Page 162</i>	Enum	4	H+48
12	V-X	Velocity vector along X-axis (m)	Double	8	H+52
13	V-Y	Velocity vector along Y-axis (m)	Double	8	H+60

Continued on Page 296

Field #	Field type	Data Description	Format	Binary Bytes	Binary Offset
14	V-Z	Velocity vector along Z-axis (m)	Double	8	H+68
15	V-X σ	Standard deviation of V-X (m)	Float	4	H+76
16	V-Y σ	Standard deviation of V-Y (m)	Float	4	H+80
17	V-Z σ	Standard deviation of V-Z (m)	Float	4	H+84
18	stn ID	Base station identification	Char[4]	4	H+88
19	V-latency	A measure of the latency in the velocity time tag in seconds. It should be subtracted from the time to give improved results.	Float	4	H+92
20	diff_age	Differential age in seconds	Float	4	H+96
21	sol_age	Solution age in seconds	Float	4	H+100
22	#obs	Number of observations tracked	Uchar	1	H+104
23	#GPSL1	Number of GPS L1 ranges used in computation	Uchar	1	H+105
24	#L1	Number of GPS L1 ranges above the RTK mask angle	Uchar	1	H+106
25	#L2	Number of GPS L2 ranges above the RTK mask angle	Uchar	1	H+107
26	Reserved		Char	1	H+108
27			Char	1	H+109
28			Char	1	H+110
29			Char	1	H+111
30	xxxx	32-bit CRC (ASCII and Binary only)	Hex	4	H+112
31	[CR][LF]	Sentence terminator (ASCII only)	-	-	-

Recommended Input:

```
log rtkxyza ontime 1
```

ASCII Example:

```
#RTKXYZA,COM1,0,65.5,FINESTEERING,1263,250320.000,00000000,9cb9,1522;
SOL_COMPUTED,NARROW_INT,-1634532.4437,-3664608.8994,4942482.7015,
0.0060,0.0118,0.0117,SOL_COMPUTED,NARROW_INT,-0.0026,0.0005,-0.0050,
0.0121,0.0236,0.0234,"AAAA",0.250,2.000,0.000,11,8,8,8,0,0,0,0*5d19a735
```

3.4.84 RXCONFIG Receiver Configuration

This log is used to output a list of all current command settings. When requested, an RXCONFIG log is output for each setting. See also the LOGLIST log on *Page 212* for a list of currently active logs.

Message ID: 128

Log Type: Polled

Field #	Field type	Data Description	Format	Binary Bytes	Binary Offset
1	header	Log header	-	H	0
2	e header	Embedded header	-	h	H
3	e msg	Embedded message	Varied	a	H + h
4	e xxxx	Embedded (inverted) 32-bit CRC (ASCII and Binary only). The embedded CRC is inverted so that the receiver will not recognize the embedded messages as messages to be output but will continue with the RXCONFIG message. If you wish to use the messages output from the RXCONFIG log, simply flip the embedded CRC around for individual messages.	Long	4	H+ h + a
5	xxxx	32-bit CRC (ASCII and Binary only)	Hex	4	H+ h + a + 4
6...	Next Log header offset = # of log headers to follow x (H + h + a + 4)				
7	[CR][LF]	Sentence terminator (ASCII only)	-	-	-

Recommended Input:

```
log rxconfiga once
```

ASCII Example¹:

```
#RXCONFIGA, COM1, 70, 72.0, UNKNOWN, 0, 1.656, 00000000, f702, 1522;
#ADJUST1PPSA, COM1, 70, 72.0, UNKNOWN, 0, 1.656, 00000000, f702, 1522;
OFF, ONCE, 0*ad21fe17*7d34bfd1
#RXCONFIGA, COM1, 69, 72.0, UNKNOWN, 0, 1.704, 00000000, f702, 1522;
#ANTENNAPOWERA, COM1, 69, 72.0, UNKNOWN, 0, 1.704, 00000000, f702, 1522;
ON*5f918e9a*8a1a5caf
#RXCONFIGA, COM1, 68, 72.0, UNKNOWN, 0, 1.714, 00000000, f702, 1522;
#APPLICATIONA, COM1, 68, 72.0, UNKNOWN, 0, 1.714, 00000000, f702, 1522;
STOP, 0, 1, 10000*ba861cde*3f28385b
#RXCONFIGA, COM1, 67, 72.0, UNKNOWN, 0, 1.722, 00000000, f702, 1522;
#CLOCKADJUSTA, COM1, 67, 72.0, UNKNOWN, 0, 1.722, 00000000, f702, 1522;
ENABLE*8b8b2e1b*1d4ec53e
#RXCONFIGA, COM1, 66, 72.0, UNKNOWN, 0, 1.726, 00000000, f702, 1522;
#CLOCKOFFSETA, COM1, 66, 72.0, UNKNOWN, 0, 1.726, 00000000, f702, 1522;
0*82da710b*704424bb
...
#RXCONFIGA, COM1, 46, 72.0, FINESTEERING, 1263, 234665.199, 00000000, f702, 1522;
#INTERFACEMODEA, COM1, 46, 72.0, FINESTEERING, 1263, 234665.199, 00000000, f702, 1522;
COM1, NOVATEL, NOVATEL, ON*5bb97afd*3df198bb
#RXCONFIGA, COM1, 45, 72.0, FINESTEERING, 1263, 234720.892, 00000000, f702, 1522;
#INTERFACEMODEA, COM1, 45, 72.0, FINESTEERING, 1263, 234720.892, 00000000, f702, 1522;
COM2, RTCA, NONE, ON*cf538e02*f378cf10
...
#RXCONFIGA, COM1, 1, 72.0, UNKNOWN, 0, 2.708, 00000000, f702, 1522;
#WAASECUTOFFA, COM1, 1, 72.0, UNKNOWN, 0, 2.708, 00000000, f702, 1522;
-5.000000000*7af1559f*e50ccace
#RXCONFIGA, COM1, 0, 72.0, FINESTEERING, 1263, 240449.214, 00000000, f702, 1522;
#LOGA, COM1, 0, 72.0, FINESTEERING, 1263, 240449.214, 00000000, f702, 1522;
COM1, BESTPOSA, ONTIME, 10.000000, 0.000000, NOHOLD*2bbec7e9*8daf0216
```

1. The embedded CRCs are flipped to make the embedded messages recognizable to the receiver. For example, consider the first embedded message above.

```
7d34bfd1: 0111110100110100101111111010001
          10001011111101001011001011110:8bfd2cbe
```

Its CRC is really 8bfd2cbe.

3.4.85 RXHWLEVELS Receiver Hardware Levels

This log contains the receiver environmental and voltage parameters. *Table 79* provides some of the minimum, maximum and typical parameters of OEM4-G2-based products.

☒ This log outputs null fields from OEM4-G2L-based products.

Message ID: 195

Log Type: Polled

Field #	Field type	Data Description	Format	Binary Bytes	Binary Offset
1	header	Log header		H	0
2	temp	Board temperature (degrees celsius)	Float	4	H
3	ant current	Approximate internal antenna current (A)	Float	4	H+4
4	core volt	CPU core voltage (V)	Float	4	H+8
5	supply volt	Receiver supply voltage (V)	Float	4	H+12
6	rf volt	5V RF supply voltage (V)	Float	4	H+16
7	int lna volt	Internal LNA voltage level (V)	Float	4	H+20
8	GPAI	General purpose analog input (V)	Float	4	H+24
9	Reserved		Float	4	H+28
10			Float	4	H+32
11	lna volt	LNA voltage (V) at GPSCard output	Float	4	H+36
12	xxxx	32-bit CRC (ASCII and Binary only)	Hex	4	H+40
13	[CR][LF]	Sentence terminator (ASCII only)	-	-	-

Recommended Input:

log rxhwlevels a ontime 60

ASCII Example:

```
#RXHWLEVELSA, COM1, 0, 64.0, FINESTEERING, 1263, 250724.830, 00000000, 863c, 1522;
46.000, 0.123, 1.296, 14.562, 4.994, 4.975, 0.000, 0.001, 0.012, 4.910*9462eebd
```

Table 79: Receiver Hardware Parameters

	Temperature	Antenna Current	Core Voltage ^a	Supply Voltage	RF Voltage	Internal LNA Voltage	GPAI	LNA Voltage
Min	-40	0	0.90	4.5	4.55	4.55	0	0
Max	100 ^b	0.10	1.18	18	5.25	5.25	2.5	30
Typical	40	0.04	1.00	12	5	5	0	5

- The shown voltage levels are for hardware revision 3.01 or higher OEM4-G2 cards. If the card's revision level is 3.00 or lower, then the voltage range is between 1.24 and 1.38 V DC.
- The board temperature is about 15°C higher than the ambient temperature. Bit 1, in *Table 81, Receiver Status* on *Page 303*, turns on as a warning when the board temperature is above 100°C and a hazardous temperature error message is generated at 110°C.

3.4.86 RXSTATUS Receiver Status

This log conveys various status parameters of the GPS receiver system. These include the Receiver Status and Error words which contain several flags specifying status and error conditions. If an error occurs (shown in the Receiver Error word) the receiver will idle all channels, turn off the antenna, and disable the RF hardware as these conditions are considered to be fatal errors. The log contains a variable number of status words to allow for maximum flexibility and future expansion.

The receiver gives the user the ability to determine the importance of the status bits. In the case of the Receiver Status, setting a bit in the priority mask will cause the condition to trigger an error. This will cause the receiver to idle all channels, turn off the antenna, and disable the RF hardware, the same as if a bit in the Receiver Error word is set. Setting a bit in an Auxiliary Status priority mask will cause that condition to set the bit in the Receiver Status word corresponding to that Auxiliary Status.

Receiver Errors automatically generate event messages. These event messages are output in RXSTATUSEVENT logs. It is also possible to have status conditions trigger event messages to be generated by the receiver. This is done by setting/clearing the appropriate bits in the event set/clear masks. The set mask tells the receiver to generate an event message when the bit becomes set. Likewise, the clear mask causes messages to be generated when a bit is cleared. See the STATUSCONFIG Configure RXSTATUSEVENT mask fields command on *Page 126* for details.

If you wish to disable all these messages without changing the bits, simply UNLOG the RXSTATUSEVENT logs on the appropriate ports.

Note that Field #4, the receiver status word as represented in *Table 81*, is also in Field #8 of the header. See the *ASCII Example* and *Table 81* on *Page 303* for clarification.

☒ Refer also to the chapter on *Built-In Status Tests* in *Volume 1* of this manual set.

Message ID: 93
Log Type: Asynch

Field #	Field type	Data Description	Format	Binary Bytes	Binary Offset
1	header	Log header		H	0
2	error	Receiver error (see <i>Table 80, Receiver Error</i> on <i>Page 302</i>). A value of zero indicates no errors.	ULong	4	H
3	# stats	Number of status codes (including Receiver Status). Normally = 4	ULong	4	H+4
4	rxstat	Receiver status word (see <i>Table 81, Receiver Status</i> on <i>Page 303</i>)	ULong	4	H+8
5	rxstat pri	Receiver status priority mask, which can be set using the STATUSCONFIG command (see <i>Page 126</i>)	ULong	4	H+12
6	rxstat set	Receiver status event set mask, which can be set using the STATUSCONFIG command (see <i>Page 126</i>)	ULong	4	H+16

Continued on Page 301

Field #	Field type	Data Description	Format	Binary Bytes	Binary Offset
7	rxstat clear	Receiver status event clear mask, which can be set using the STATUSCONFIG command (see Page 126)	ULong	4	H+20
8	aux1stat	Auxiliary 1 status word (see Table 82, Auxiliary 1 Status on Page 304)	ULong	4	H+24
9	aux1stat pri	Auxiliary 1 status priority mask, which can be set using the STATUSCONFIG command (see Page 126)	ULong	4	H+28
10	aux1stat set	Auxiliary 1 status event set mask, which can be set using the STATUSCONFIG command (see Page 126)	ULong	4	H+32
11	aux1stat clear	Auxiliary 1 status event clear mask, which can be set using the STATUSCONFIG command (see Page 126)	ULong	4	H+36
12	aux2stat	Auxiliary 2 status word (see Table 83, Auxiliary 2 Status on Page 304)	ULong	4	H+40
13	aux2stat pri	Auxiliary 2 status priority mask, which can be set using the STATUSCONFIG command (see Page 126)	ULong	4	H+44
14	aux2stat set	Auxiliary 2 status event set mask, which can be set using the STATUSCONFIG command	ULong	4	H+48
15	aux2stat clear	Auxiliary 2 status event clear mask, which can be set using the STATUSCONFIG command	ULong	4	H+52
16	aux3stat	Auxiliary 3 status word (see Table 84, Auxiliary 3 Status on Page 304)	ULong	4	H+56
17	aux3stat pri	Auxiliary 3 status priority mask, which can be set using the STATUSCONFIG command (see Page 126)	ULong	4	H+60
18	aux3stat set	Auxiliary 3 status event set mask, which can be set using the STATUSCONFIG command	ULong	4	H+64
19	aux3stat clear	Auxiliary 3 status event clear mask, which can be set using the STATUSCONFIG command	ULong	4	H+68
20...	Next status code offset = H + 8 + (# stats x 16)				
variable	xxxx	32-bit CRC (ASCII and Binary only)	Hex	4	H+8+(#stats x 64)
variable	[CR][LF]	Sentence terminator (ASCII only)	-	-	-

Recommended Input:

```
log rxstatusa onchanged
```

ASCII Example:

```
#RXSTATUSA, COM1, 0, 67.5, FINESTEERING, 1263, 250821.428, 00000000, 643c, 1522;
00000000, 4, 00000000, 00000000, 00000000, 00000000, 00000084, 00000008, 00000000,
00000000, 00000000, 00000000, 00000000, 00000000, 00000000, 00000000,
00000000, 00000000*a98d7a51
```

Table 80: Receiver Error

Nibble #	Bit #	Mask	Description	Bit = 0	Bit = 1
N0	0	0x00000001	Dynamic Random Access Memory (DRAM) status ^a	OK	Error
	1	0x00000002	Invalid firmware	OK	Error
	2	0x00000004	ROM status	OK	Error
	3	Reserved			
N1	4	0x00000010	Electronic Serial Number (ESN) access status	OK	Error
	5	0x00000020	Authorization code status	OK	Error
	6	0x00000040	Slow ADC status	OK	Error
	7	0x00000080	Supply voltage status	OK	Error
N2	8	0x00000100	Thermometer status	OK	Error
	9	0x00000200	Temperature status (as compared against acceptable limits)	OK	Error
	10	0x00000400	MINOS4 status	OK	Error
	11	0x00000800	PLL RF1 hardware status - L1	OK	Error
N3	12	0x00001000	PLL RF2 hardware status - L2	OK	Error
	13	0x00002000	RF1 hardware status - L1	OK	Error
	14	0x00004000	RF2 hardware status - L2	OK	Error
	15	0x00008000	NVM status	OK	Error
N4	16	0x00010000	Software resource limit	OK	Error
	17	0x00020000	Reserved		
	18	0x00040000			
	19	0x00080000			
N5	20	0x00100000	Remote loading has begun	No	Yes
	21	0x00200000	Export restriction	OK	Error
	22	0x00400000	Reserved		
	23	0x00800000			
N6	24	0x01000000			
	25	0x02000000			
	26	0x04000000			
	27	0x08000000			
N7	28	0x10000000			
	29	0x20000000			
	30	0x40000000			
	31	0x80000000	Component hardware failure	OK	Error

a. RAM failure on an OEM4-G2/G2L may also be indicated by a flashing red LED.

Table 81: Receiver Status

Nibble #	Bit #	Mask	Description	Bit = 0	Bit = 1
N0	0	0x00000001	Error flag, see <i>Table 80, Receiver Error on Page 302</i>	No error	Error
	1	0x00000002	Temperature status	Within specifications	Warning
	2	0x00000004	Voltage supply status	OK	Warning
	3	0x00000008	Antenna power status See <i>ANTENNAPOWER Control</i>	Powered	Not powered
N1	4	0x00000010	Reserved		
	5	0x00000020	Antenna open flag	OK	Open
	6	0x00000040	Antenna shorted flag	OK	Shorted
	7	0x00000080	CPU overload flag	No overload	Overload
N2	8	0x00000100	COM1 buffer overrun flag	No overrun	Overrun
	9	0x00000200	COM2 buffer overrun flag	No overrun	Overrun
	10	0x00000400	COM3 buffer overrun flag	No overrun	Overrun
	11	0x00000800	USB buffer overrun flag ^a	No overrun	Overrun
N3	12	0x00001000	Reserved		
	13	0x00002000			
	14	0x00004000			
	15	0x00008000	RF1 AGC status	OK	Bad
N4	16	0x00010000	Reserved		
	17	0x00020000	RF2 AGC status	OK	Bad
	18	0x00040000	Almanac flag	Valid	Invalid
	19	0x00080000	Position solution flag	Valid	Invalid
N5	20	0x00100000	Position fixed flag, see <i>FIX Constrain to fixed height or</i>	Not fixed	Fixed
	21	0x00200000	Clock steering status	Enabled	Disabled
	22	0x00400000	Clock model flag	Valid	Invalid
	23	0x00800000	OEM4-G2L/OEM4-G2 external oscillator flag ^b	Disabled	Enabled
N6	24	0x01000000	Software resource	OK	Warning
	25	0x02000000	Reserved		
	26	0x04000000			
	27	0x08000000			
N7	28	0x10000000			
	29	0x20000000	AUX3 status event flag	No event	Event
	30	0x40000000	AUX2 status event flag	No event	Event
	31	0x80000000	AUX1 status event flag	No event	Event

a. This flag indicates if any of the three USB ports (USB1, USB2, or USB3) are overrun. See the auxiliary status word for the specific port for which the buffer is overrun.

b. For obsolete Euro4 products, the values for this bit are 0 = PLL Not Locked and 1 = PLL Locked.

Table 82: Auxiliary 1 Status

Nibble #	Bit #	Mask	Description	Bit = 0	Bit = 1
N0	0	0x00000001	COM1 connection status	Connected	Not connected
	1	0x00000002	COM2 connection status	Connected	Not connected
	2	0x00000004	COM3 connection status	Connected	Not connected
	3	0x00000008	Position averaging	Off	On
N1	4	0x00000010	Reserved		
	5	0x00000020			
	6	0x00000040			
	7	0x00000080	USB connection status	Connected	Not connected
N2	8	0x00000100	USB1 buffer overrun flag	No overrun	Overrun
	9	0x00000200	USB2 buffer overrun flag	No overrun	Overrun
	10	0x00000400	USB3 buffer overrun flag	No overrun	Overrun
	11	0x00000800	Reserved		

Table 83: Auxiliary 2 Status

Nibble #	Bit #	Mask	Description	Bit = 0	Bit = 1
N0	0	0x00000001	Reserved		

Table 84: Auxiliary 3 Status

Nibble #	Bit #	Mask	Description	Bit = 0	Bit = 1
N0	0	0x00000001	Reserved		

3.4.87 RXSTATUSEVENT Status Event Indicator

This log is used to output event messages as indicated in the RXSTATUS log. An event message is automatically generated for all receiver errors, which are indicated in the receiver error word. In addition, event messages can be generated when other conditions, which are indicated in the receiver status and auxiliary status words, are met. Whether or not an event message is generated under these conditions is specified using the STATUSCONFIG command, which is detailed in *Section 2.6.57, STATUSCONFIG Configure RXSTATUSEVENT mask fields on Page 126*.

On startup, the receiver is set to log the RXSTATUSEVENTA log ONNEW on all ports. You can remove this message by using the UNLOG command.

☒ See also the chapter on *Built-In Status Tests* in *Volume 1* of this manual set.

Message ID: 94

Log Type: Asynch

Field #	Field type	Data Description	Format	Binary Bytes	Binary Offset
1	header	Log header		H	0
2	word	The status word that generated the event message (see <i>Table 85 on Page 306</i>)	Enum	4	H
3	bit position	Location of the bit in the status word (see <i>Table 81, Receiver Status on Page 303</i>)	Ulong	4	H+4
4	event	Event type (see <i>Table 86 on Page 306</i>)	Enum	4	H+8
3	description	This is a text description of the event or error	Char[32]	32	H+12
5	xxxx	32-bit CRC (ASCII and Binary only)	Hex	4	H+44
6	[CR][LF]	Sentence terminator (ASCII only)	-	-	-

Recommended Input:

log rxstatuseventa onchanged

ASCII Example 1:

```
#RXSTATUSEVENTA,COM1,0,46.5,FINESTEERING,1263,251784.510,00000000,b967,1522;
STATUS,19,SET,"No Valid Position Calculated"*ca0dbffb
```

ASCII Example 2:

```
#RXSTATUSEVENTA,COM1,0,0.0,FINESTEERING,1263,329182.498,00480100,b967,1522;
STATUS,8,SET,"COM1 Transmit Buffer Overrun"*c05ad726
```

Table 85: Status Word

Word (binary)	Word (ASCII)	Description
0	ERROR	Receiver Error word
1	STATUS	Receiver Status word
2	AUX1	Auxiliary 1 Status word
3	AUX2	Auxiliary 2 Status word
4	AUX3	Auxiliary 3 Status word

Table 86: Event Type

Event (binary)	Event (ASCII)	Description
0	CLEAR	Bit was cleared
1	SET	Bit was set

3.4.88 SATVIS Satellite Visibility

Satellite visibility log with additional satellite information.

Message ID: 48

Log Type: Synch

Field #	Field type	Data Description	Format	Binary Bytes	Binary Offset
1	header	Log header		H	0
2	sat vis	Is satellite visibility valid? 1 = TRUE 0 = FALSE	Enum	4	H
3	comp alm	Was complete almanac used? 1 = TRUE 0 = FALSE	Enum	4	H+4
4	#sat	Number of satellites with information to follow	Ulong	4	H+8
5	PRN	GPS satellite PRN number of range measurement.	Short	2	H+12
6	Reserved		Short	2	H+14
7	health	Satellite health ^a	Ulong	4	H+16
8	elev	Elevation (degrees)	Double	8	H+20
9	az	Azimuth (degrees)	Double	8	H+28
10	true dop	Theoretical Doppler of satellite	Double	8	H+36
11	app dop	Apparent Doppler for this receiver	Double	8	H+44
12	Next satellite offset = H + 12 + (#sat x 40)				
variable	xxxx	32-bit CRC (ASCII and Binary only)	Hex	4	H+12+ (#sat x 40)
variable	[CR][LF]	Sentence terminator (ASCII only)	-	-	-

- a. Satellite health values may be found in ICD-GPS-200. To obtain copies of ICD-GPS-200, refer to ARINC in the *Standards and References* section of the *GPS+ Reference Manual* available on our website at <http://www.novatel.com/support/docupdates.htm>.

Recommended Input:

```
log satvisa ontime 60
```

ASCII Example:

```
#SATVISA, COM1, 0, 58.0, FINESTEERING, 1263, 251958.000, 00000000, 0947, 1522;
TRUE, TRUE, 30,
21, 0, 0, 81.8, 309.6, 595.377, 595.395,
18, 0, 0, 53.8, 218.7, 2250.626, 2250.644,
26, 0, 0, 42.9, 90.6, 522.751, 522.769,
29, 0, 0, 39.1, 69.2, -643.078, -643.060,
6, 0, 255, 33.4, 164.3, -3184.244, -3184.227,
...
20, 0, 0, -80.6, 258.8, 454.007, 454.024*b6185711
```

3.4.89 SATXYZ SV Position in ECEF Cartesian Coordinates

When combined with a RANGE log, this data set contains the decoded satellite information necessary to compute the solution: satellite coordinates (ECEF WGS84), satellite clock correction, ionospheric corrections and tropospheric corrections (Hopfield model). The corrections are to be added to the pseudoranges. Only those satellites that are healthy are reported here. See also, *Figure 8 on Page 170*.

Message ID: 270

Log Type: Synch

Field #	Field type	Data Description	Format	Binary Bytes	Binary Offset
1	header	Log header		H	0
2	Reserved		Double	8	H
3	#sat	Number of satellites with Cartesian information to follow	Ulong	4	H+8
4	prn	Satellite PRN number	Ulong	4	H+12
5	x	Satellite X coordinates (ECEF, m)	Double	8	H+16
6	y	Satellite Y coordinates (ECEF, m)	Double	8	H+24
7	z	Satellite Z coordinates (ECEF, m)	Double	8	H+32
8	clk corr	Satellite clock correction (m)	Double	8	H+40
9	ion corr	Ionospheric correction (m)	Double	8	H+48
10	trop corr	Tropospheric correction (m)	Double	8	H+56
11	Reserved		Double	8	H+64
12			Double	8	H+72
13	Next satellite offset = H + 12 + (#sat x 68)				
variable	xxxx	32-bit CRC (ASCII and Binary only)	Hex	4	H+12+ (#sat x 68)
variable	[CR][LF]	Sentence terminator (ASCII only)	-	-	-

Recommended Input:

log satxyz ontme 1

ASCII Example:

```
#SATXYZA,COM1,0,59.0,FINESTEERING,1263,252053.000,00000000,6f3c,1522;
0.0,10,
29,11508502.0384,-13745489.5563,19839768.7384,70379.265,5.540440855,
3.723844559,0.00000000,0.00000000,
10,19903841.6238,-3879528.2619,17251402.5656,12392.949,10.511089723,
13.548267507,0.00000000,0.00000000,
...
3,-13242007.0491,10808251.4523,20184122.7616,28761.582,8.445311721,
8.586959159,0.00000000,0.00000000*9bc99d1e
```

3.4.90 TIME Time Data

This log provides several time related pieces of information. These include receiver clock offset and UTC time and offset. It also reports any error in the 1PPS signal.

To find out the time of the last 1PPS output signal, use the TIME log 'onnew'.

Typically you will intercept the 1PPS output signal using hardware with an accuracy of about 50 ns, and then wait a few milliseconds to receive the TIMEA/B output message over the serial port to find out what was the exact time of the last 1PPS output.

Message ID: 101
Log Type: Synch

Field #	Field type	Data Description	Format	Binary Bytes	Binary Offset
1	header	Log header		H	0
2	clock status	Clock model status (not including current measurement data), see <i>Table 49 on Page 173</i>	Enum	4	H
3	offset	Receiver clock offset, in seconds from GPS time. A positive offset implies that the receiver clock is ahead of GPS time. To derive GPS time, use the following formula: GPS time = receiver time - offset	Double	8	H+4
4	offset std	Receiver clock offset standard deviation.	Double	8	H+12
5	utc offset	The offset of GPS time from UTC time, computed using almanac parameters. UTC time is GPS time plus the current UTC offset plus the receiver clock offset: UTC time = GPS time + offset + UTC offset	Double	8	H+20
6	utc year	UTC year	Ulong	4	H+28
7	utc month	UTC month (0-12) ^a	Uchar	1	H+32
8	utc day	UTC day (0-31) ^a	Uchar	1	H+33
9	utc hour	UTC hour (0-23)	Uchar	1	H+34
10	utc min	UTC minute (0-59)	Uchar	1	H+35
11	utc millisec	UTC millisecond (0-60999) ^b	Ulong	4	H+36
12	utc status	UTC status 0 = Invalid 1 = Valid	Enum	4	H+40
13	xxxx	32-bit CRC (ASCII and Binary only)	Hex	4	H+44
14	[CR][LF]	Sentence terminator (ASCII only)	-	-	-

- a. If UTC time is unknown, the values for month and day will be 0.
- b. Maximum of 60999 when leap second is applied.

Recommended Input:

log timea ontime 1

ASCII Example:

```
#TIMEA, COM1, 0, 63.0, FINESTEERING, 1263, 252384.000, 00000000, 9924, 1522;
VALID, -5.405211352e-09, 0.000000103, -13.00000000175, 2004, 3, 23,
22, 6, 11000, VALID*33e45c7b
```

3.4.91 **TIMESYNC Synchronize Time Between GPS Receivers**

The TIMESYNC log is used in conjunction with the ADJUST1PPS command, see *Page 42*, to synchronize the time between GPS receivers.

The time data embedded in this log represents the time of the most recent 1PPS signal. This log should be issued from a communications port within 200 ms, of the last 1PPS event. See *Figure 1, 1PPS Alignment on Page 42* for an illustration.

Refer also to the *Transfer Time Between Receivers* section in *Volume 1* of this manual set.

Message ID: 492
Log Type: Synch

Field #	Field type	Data Description	Format	Binary Bytes	Binary Offset
1	header	Log header		H	0
2	week	GPS week number	Ulong	4	H
3	mseconds	Number of milliseconds into the GPS week.	Ulong	4	H+4
4	time status	GPS Time Status, see <i>Table 7, GPS Time Status on Page 21</i> .	Enum	4	H+8
5	xxxx	32-bit CRC (ASCII and Binary only)	Hex	4	H+12
6	[CR][LF]	Sentence terminator (ASCII only)	-	-	-

Recommended Input:

```
log timesync ontime 1
```

ASCII Example:

```
#TIMESYNCA,COM1,0,56.0,FINESTEERING,1263,252431.000,00000000,bd3f,1522;  
1263,252431000,FINESTEERING*2b63eba8
```

3.4.92 TRACKSTAT Tracking Status

These logs provide channel tracking status information for each of the receiver parallel channels.

If both the L1 and L2 signals are being tracked for a given PRN, two entries with the same PRN will appear in the tracking status logs. As shown in 62, *Channel Tracking Status on Page 237* these entries can be differentiated by bit 20, which is set if there are multiple observables for a given PRN, and bits 21-22, which denote whether the observation is for L1 or L2. This is to aid in parsing the data.

Message ID: 83
Log Type: Synch

Field #	Field Type	Data Description	Format	Binary Bytes	Binary Offset
1	header	Log header		H	0
2	sol status	Solution status (see Table 48, <i>Solution Status on Page 163</i>).	Enum	4	H
3	pos type	Position type (see Table 47, <i>Position or Velocity Type on Page 162</i>).	Enum	4	H+4
4	cutoff	Tracking elevation cut-off angle	Float	4	H+8
5	# chans	Number of hardware channels with information to follow	Long	4	H+12
6	PRN	GPS satellite PRN number of range measurement.	Short	2	H+16
7	Reserved		Short	2	H+18
8	ch-tr-status	Channel tracking status (see Table 62, <i>Channel Tracking Status on Page 237</i>)	ULong	4	H+20
9	psr	Pseudorange (m) - if this field is zero but the channel tracking status in the previous field indicates that the card is phase locked and code locked, the pseudorange has not been calculated yet.	Double	8	H+24
10	Doppler	Doppler frequency (Hz)	Float	4	H+32
11	C/No	Carrier to noise density ratio (dB-Hz)	Float	4	H+36
12	locktime	Number of seconds of continuous tracking (no cycle slips)	Float	4	H+40
13	psr res	Pseudorange residual from pseudorange filter (m)	Float	4	H+44
14	reject	Range reject code from pseudorange filter (see Table 87, <i>Range Reject Code on Page 312</i>)	Enum	4	H+48
15	psr weight	Pseudorange filter weighting	Float	4	H+52
16...	Next PRN offset = H + 16 + (#chans x 40)				
variable	xxxx	32-bit CRC (ASCII and Binary only)	Hex	4	H+16+ (#chans x 40)
variable	[CR][LF]	Sentence terminator (ASCII only)	-	-	-

Recommended Input:

```
log trackstata ontime 1
```

ASCII Example:

```
#TRACKSTATA, COM1, 0, 59.0, FINESTEERING, 1263, 252508.000, 00000000, 457c, 1522;
SOL_COMPUTED, NARROW_INT, 5.0, 24,
29, 0, 18109c04, 22281104.238, -998.109, 47.044, 683.730, -0.015, GOOD, 0.804,
29, 0, 11309c0b, 22281107.946, -777.750, 39.767, 680.380, 0.000, OBSL2, 0.000,
10, 0, 18109c24, 25113156.662, -3666.781, 40.094, 675.630, -0.002, GOOD, 0.504,
10, 0, 11309c2b, 25113163.682, -2857.230, 25.752, 671.380, 0.000, OBSL2, 0.000,
...
22, 0, 18109d04, 23489276.752, 3328.996, 41.835, 661.624, 0.068, GOOD, 0.579,
22, 0, 11309d0b, 23489280.666, 2594.023, 34.577, 657.780, 0.000, OBSL2, 0.000,
...
122, 0, 0c023d64, 40619875.840, -4.707, 37.977, 679.836, 0.000, NOEPHEMERIS, 0.000,
134, 0, 0c023584, 0.000, 4.906, 31.739, 0.252, 0.000, NA, 0.000*7feb6c657
```

Table 87: Range Reject Code

Reject Code (binary)	Reject Code (ASCII)	Description
0	GOOD	Observations are good
1	BADHEALTH	Bad satellite health is indicated by ephemeris data
2	OLDEPHEMERIS	Old ephemeris due to date not being updated during the last 3 hours
3	ECCENTRICANOMALY	Eccentric anomaly error during computation of the satellite's position
4	TRUEANOMALY	True anomaly error during computation of the satellite's position
5	SATCOORDINATEERROR	Satellite coordinate error during computation of the satellite's position
6	ELEVATIONERROR	Elevation error due to the satellite being below the cut-off angle
7	MISCLOSURE	Misclosure too large due to excessive gap between estimated and actual positions
8	NODIFFCORR	No compatible differential correction is available for this particular satellite
9	NOEPHEMERIS	Ephemeris data for this satellite has not yet been received
10	INVALIDIODE	Invalid IODE (Issue Of Data Ephemeris) due to mismatch between differential stations
11	LOCKEDOUT	Locked out: satellite is excluded by the user (LOCKOUT command)
12	LOWPOWER	Low power: satellite is rejected due to low carrier/noise ratio
13	OBSL2	L2 measurements are not being used by the filter
16	NOIONOCORR	No compatible ionospheric correction is available for this particular satellite
99	NA	No observation (a reject code is not applicable)
100	BAD_INTEGRITY	The integrity of the pseudorange is bad

3.4.93 VALIDMODELS Valid Model Information

This log gives a list of valid authorized models available and expiry date information.

See the VERSION log on *Page 314* for currently active models. Use the MODEL command, see *Page 97*, to change the currently active model. See the AUTH command on *Page 53* to add new models (up to a maximum of 5 models).

If a model has no expiry date it will report the year, month and day fields as 0, 0 and 0 respectively.

Message ID: 206

Log Type: Polled

Field #	Field type	Data Description	Format	Binary Bytes	Binary Offset
1	header	Log header		H	0
2	#mod	Number of models with information to follow.	Ulong	4	H
3	model	Model name	String [max. 16]	Vari-able ^a	Variable
4	expyear	Expiry year	Ulong	4	H+20
5	expmonth	Expiry month	Ulong	4	H+24
6	expday	Expiry day	Ulong	4	H+28
7...	Next model offset = H + 4 + (#mods x 28)				
variable	xxxx	32-bit CRC (ASCII and Binary only)	Hex	4	H+4+ (#mods x 28)
variable	[CR][LF]	Sentence terminator (ASCII only)	-	-	-

- a. In the binary log case additional bytes of padding are added to maintain 4 byte alignment

Recommended Input:

log validmodelsa once

ASCII Example:

```
#VALIDMODELSA,COM1,0,70.5,FINESTEERING,1263,311382.950,00000000,342f,1522;3,"
INSRT2W",0,0,0,"RT2",0,0,0,"RT2WA",0,0,0*b6be57bf
```

3.4.94 VERSION Version Information

This log contains the version information for all components of a system. When using a standard receiver, there will only be one component in the log.

A component may be hardware (for example, a receiver or data collector) or firmware in the form of applications or data (for example, data blocks for height models, user applications or Field Programmable Gate-Array (FPGA) configurations). See *Table 89, VERSION Log: Field Formats on Page 316* for details on the format of key fields.

See also the VALIDMODELS log on *Page 313*.

Message ID: 37
Log Type: Polled

Field #	Field type	Data Description	Format	Binary Bytes	Binary Offset
1	header	Log header		H	0
2	# comp	Number of components (cards, and so on)	Long	4	H
3	type	Component type (see <i>Table 88, Component Types on Page 315</i>)	Enum	4	H+4
4	model	Model	Char[16]	16	H+8
5	psn	Product serial number	Char[16]	16	H+24
6	hw version	Hardware version	Char[16]	16	H+40
7	sw version	Firmware software version	Char[16]	16	H+56
8	boot version	Boot code version	Char[16]	16	H+72
9	comp date	Firmware compile date	Char[12]	12	H+88
10	comp time	Firmware compile time	Char[12]	12	H+100
11...	Next component offset = H + 4 + (#comp x 108)				
variable	xxxx	32-bit CRC (ASCII and Binary only)	Hex	4	H+4+ (#comp x 108)
variable	[CR][LF]	Sentence terminator (ASCII only)	-	-	-

Recommended Input:

log versiona once

ASCII Example:

```
#VERSIONA, COM1, 0, 70.5, FINESTEERING, 1263, 311409.177, 00000000, 3681, 1522;1, GPSCARD, "RT2WA", "SVA03130089", "OEM4g2-2.00-X2T", "2.200A1", "2.000", "2004/Feb/10", "09:53:05"*420715a2
```

- ☒ The field types and formats remain constant for all components. However, unique applications' products may contain differences in the contents of the fields and their meanings. Below is an example of a VERSION log from a ProPak-LB receiver.

```
#VERSIONA,COM1,0,67.5,FINESTEERING,1163,485999.875,00000000,e249,710;4,
GPSCARD,"RT2WLBA","SPA02090052","OEM4-6.03-
22T","1.400D86","1.005db","2002/Apr/24","15:17:29",
```

```
DB_OMNISTARXILINX,"OmniXilinx","0","","102","","","2002/Apr/11","10:56:48",
```

```
DB_OMNISTARDSP,"OmniDSP","0","","1.000S10","","","2002/Apr/11","10:56:46",
```

```
IBOARD,"OMNISTAR","07f20040","6.01-102","1.000S10","704309","",""*74762c4f
```

Table 88: Component Types

Binary	ASCII	Description
0	UNKNOWN	Unknown component
1	GPSCARD	OEM4 family component
2	CONTROLLER	Data collector
3	ENCLOSURE	OEM card enclosure
4	IBOARD	OmniSTAR CAN ^a interface board
5-6	Reserved	
7	IMUCARD	IMU card
981073920 (0x3A7A0000)	DB_HEIGHTMODEL	Height/track model data
981073921 (0x3A7A0001)	DB_USERAPP	User application firmware
981073922 (0x3A7A0002)	DB_OMNISTARDSP	OmniSTAR DSP ^a firmware
981073924 (0x3A7A0004)	DB_OMNISTARXILINX	OmniSTAR FPGA ^a firmware
981073925 (0x3A7A0005)	DB_USERAPPAUTO	Auto-starting user application firmware

- a. Please refer to the Acronyms section in the *GPS+ Reference Manual* available from our website at <http://www.novatel.com/support/docupdates.htm>.

Table 89: VERSION Log: Field Formats

Field Type	Field Format (ASCII)	Description
hw version	P-RS-CCC	P = hardware platform (for example, OEM4) R = hardware revision (for example, 3.00) S = processor revision (for example, A) ^a CCC = COM port configuration (for example, 22T) ^b
sw version, boot version	VV.RRR[Xxxx]	VV = major revision number RRR = minor revision number X = Special (S), Beta (B), Internal Development (D, A) xxx = number
comp date	YYYY/MM/DD	YYYY = year MM = month DD = day (1 - 31)
comp time	HH:MM:SS	HH = hour MM = minutes SS = seconds

- a. This field may appear empty if the processor is not stamped with revision information
- b. One character for each of the COM ports 1, 2, and 3. Characters are:
2 for RS-232, 4 for RS-422, T for LV-TTL, and X for user-selectable (valid for COM1 of the OEM4-G2 only). Therefore, the example is for a receiver that uses RS-232 for COM 1 and COM 2 and LV-TTL for COM 3.

3.4.95 WAAS0 Remove PRN from Solution SBAS

This message tells you, when you are using SBAS messages, not to use a specific PRN message for a period of time outlined in the SBAS signal specification.

See the SBASCONTROL command on how the WAAS0 message relates to the SBAS testing modes.

Message ID: 290

Log Type: Asynch

Field #	Field type	Data Description	Format	Binary Bytes	Binary Offset
1	header	Log header		H	0
2	prn	Source PRN message - also PRN not to use.	Ulong	4	H
3	xxxx	32-bit CRC (ASCII and Binary only)	Hex	4	H+4
4	[CR][LF]	Sentence terminator (ASCII only)	-	-	-

Recommended Input:

log WAAS0 onchanged

ASCII Example:

```
#WAAS0A, COM1, 0, 68.5, SATTIME, 1093, 161299.000, 00040020, 7d6a, 209;122*e9a5ab08
```

3.4.97 WAAS2 Fast Correction Slots 0-12 SBAS

WAAS2 are fast corrections for slots 0-12 in the mask of WAAS1. This message may or may not come when SBAS is in testing mode (see the SBASCONTROL command for details).

Message ID: 296

Log Type: Asynch

Field #	Field type	Data Description	Format	Binary Bytes	Binary Offset	Scaling
1	header	Log header		H	0	
2	prn	Source PRN of message.	Ulong	4	H	-
3	iodf	Issue of fast corrections data.	Ulong	4	H+4	-
4	iodp	Issue of PRN mask data.	Ulong	4	H+8	-
5	prc0	prc(i): Fast corrections (-2048 to +2047) for the prn in slot i (i = 0-12).	Long	4	H+12	-
6	prc1		Long	4	H+16	-
7	prc2		Long	4	H+20	-
8	prc3		Long	4	H+24	-
9	prc4		Long	4	H+28	-
10	prc5		Long	4	H+32	-
11	prc6		Long	4	H+36	-
12	prc7		Long	4	H+40	-
13	prc8		Long	4	H+44	-
14	prc9		Long	4	H+48	-
15	prc10		Long	4	H+52	-
16	prc11		Long	4	H+56	-
17	prc12		Long	4	H+60	-
18	udre0	udre(i): User differential range error indicator for the prn in slot i (i = 0-12).	Ulong	4	H+64	See Table 90
19	udre1		Ulong	4	H+68	
20	udre2		Ulong	4	H+72	
21	udre3		Ulong	4	H+76	
22	udre4		Ulong	4	H+80	
23	udre5		Ulong	4	H+84	
24	udre6		Ulong	4	H+88	
25	udre7		Ulong	4	H+92	
26	udre8		Ulong	4	H+96	
27	udre9		Ulong	4	H+100	
28	udre10		Ulong	4	H+104	
29	udre11		Ulong	4	H+108	
30	udre12		Ulong	4	H+112	
31	xxxx	32-bit CRC (ASCII and Binary only)	Hex	4	H+116	-
32	[CR][LF]	Sentence terminator (ASCII only)	-	-	-	-

Recommended Input:

log WAAS2 onchanged

ASCII Example:

```
#WAAS2A,COM1,0,67.0,SATTIME,1263,312292.000,00000000,e194,1522;
122,1,1,2047,2047,2047,0,1,2047,0,0,-4,2047,2,2047,6,14,14,14,
6,8,15,5,6,6,14,6,14,12*304f9b44
```

Table 90: Evaluation of UDREI

UDREI ^a	UDRE meters	$\sigma^2_{i,udre}$ meters ²
0	0.75	0.0520
1	1.0	0.0924
2	1.25	0.1444
3	1.75	0.2830
4	2.25	0.4678
5	3.0	0.8315
6	3.75	1.2992
7	4.5	1.8709
8	5.25	2.5465
9	6.0	3.3260
10	7.5	5.1968
11	15.0	20.7870
12	50.0	230.9661
13	150.0	2078.695
14	Not Monitored	Not Monitored
15	Do Not Use	Do Not Use

- a. The σ^2 UDRE broadcast in WAAS2, WAAS3, WAAS4, WAAS5, WAAS6 and WAAS24 applies at a time prior to or at the time of applicability of the associated corrections.

3.4.98 WAAS3 Fast Corrections Slots 13-25 SBAS

WAAS3 are fast corrections for slots 13-25 in the mask of WAAS1. This message may or may not come when SBAS is in testing mode (see the SBASCONTROL command for details).

Message ID: 301

Log Type: Asynch

Field #	Field type	Data Description	Format	Binary Bytes	Binary Offset	Scaling
1	header	Log header		H	0	
2	prn	Source PRN of message.	Ulong	4	H	-
3	iodf	Issue of fast corrections data.	Ulong	4	H+4	-
4	iodp	Issue of PRN mask data.	Ulong	4	H+8	-
5	prc13	prc(i): Fast corrections (-2048 to +2047) for the prn in slot i (i = 13-25).	Long	4	H+12	-
6	prc14		Long	4	H+16	-
7	prc15		Long	4	H+20	-
8	prc16		Long	4	H+24	-
9	prc17		Long	4	H+28	-
10	prc18		Long	4	H+32	-
11	prc19		Long	4	H+36	-
12	prc20		Long	4	H+40	-
13	prc21		Long	4	H+44	-
14	prc22		Long	4	H+48	-
15	prc23		Long	4	H+52	-
16	prc24		Long	4	H+56	-
17	prc25		Long	4	H+60	-
18	udrei13	udre(i): User differential range error indicator for the prn in slot i (i = 13-25).	Ulong	4	H+64	See Table 90
19	udrei14		Ulong	4	H+68	
20	udrei15		Ulong	4	H+72	
21	udrei16		Ulong	4	H+76	
22	udrei17		Ulong	4	H+80	
23	udrei18		Ulong	4	H+84	
24	udrei19		Ulong	4	H+88	
25	udrei20		Ulong	4	H+92	
26	udrei21		Ulong	4	H+96	
27	udrei22		Ulong	4	H+100	
28	udrei23		Ulong	4	H+104	
29	udrei24		Ulong	4	H+108	
30	udrei25		Ulong	4	H+112	
31	xxxx	32-bit CRC (ASCII and Binary only)	Hex	4	H+116	-
32	[CR][LF]	Sentence terminator (ASCII only)	-	-	-	-

Recommended Input:

log WAAS3 onchanged

ASCII Example:

```
#WAAS3A, COM1, 0, 71.0, SATTIME, 1263, 312551.000, 00000000, bff5, 1522;  
122, 0, 1, 2047, 2047, 2047, 2047, 2047, 1, 2047, 2047, 2047, 13, 2047, 0,  
2047, 14, 14, 14, 14, 14, 6, 14, 14, 14, 8, 14, 12, 14*92ea5ba9
```

3.4.99 WAAS4 Fast Correction Slots 26-38 SBAS

WAAS4 are fast corrections for slots 26-38 in the mask of WAAS1. This message may or may not come when SBAS is in testing mode (see the SBASCONTROL command for details).

Message ID: 302

Log Type: Asynch

Field #	Field type	Data Description	Format	Binary Bytes	Binary Offset	Scaling
1	header	Log header		H	0	
2	prn	Source PRN of message.	Ulong	4	H	-
3	iodf	Issue of fast corrections data.	Ulong	4	H+4	-
4	iodp	Issue of PRN mask data.	Ulong	4	H+8	-
5	prc26	prc(i): Fast corrections (-2048 to +2047) for the prn in slot i (i = 26-38).	Long	4	H+12	-
6	prc27		Long	4	H+16	-
7	prc28		Long	4	H+20	-
8	prc29		Long	4	H+24	-
9	prc30		Long	4	H+28	-
10	prc31		Long	4	H+32	-
11	prc32		Long	4	H+36	-
12	prc33		Long	4	H+40	-
13	prc34		Long	4	H+44	-
14	prc35		Long	4	H+48	-
15	prc36		Long	4	H+52	-
16	prc37		Long	4	H+56	-
17	prc38		Long	4	H+60	-
18	udrei26	udre(i): User differential range error indicator for the prn in slot i (i = 26-38).	Ulong	4	H+64	See Table 90
19	udrei27		Ulong	4	H+68	
20	udrei28		Ulong	4	H+72	
21	udrei29		Ulong	4	H+76	
22	udrei30		Ulong	4	H+80	
23	udrei31		Ulong	4	H+84	
24	udrei32		Ulong	4	H+88	
25	udrei33		Ulong	4	H+92	
26	udrei34		Ulong	4	H+96	
27	udrei35		Ulong	4	H+100	
28	udrei36		Ulong	4	H+104	
29	udrei37		Ulong	4	H+108	
30	udrei38		Ulong	4	H+112	
31	xxxx	32-bit CRC (ASCII and Binary only)	Hex	4	H+116	-
32	[CR][LF]	Sentence terminator (ASCII only)	-	-	-	-

Recommended Input:

log WAAS4 onchanged

ASCII Example:

```
#WAAS4A, COM1, 0, 58.0, SATTIME, 1093, 163399.000, 00000020, b4b0, 209;  
122, 0, 3, 2047, 3, -1, 2047, 2047, 2047, -3, -1, 5, 3, 3,  
2047, 2, 14, 3, 3, 14, 14, 14, 6, 3, 4, 5, 4, 14, 3*2e0894b1
```

3.4.100 WAAS5 Fast Correction Slots 39-50 SBAS

WAAS5 are fast corrections for slots 39-50 in the mask of WAAS1. This message may or may not come when SBAS is in testing mode (see the SBASCONTROL command for details).

Message ID: 303

Log Type: Asynch

Field #	Field type	Data Description	Format	Binary Bytes	Binary Offset	Scaling
1	header	Log header		H	0	
2	prn	Source PRN of message.	Ulong	4	H	-
3	iodf	Issue of fast corrections data.	Ulong	4	H+4	-
4	iodp	Issue of PRN mask data.	Ulong	4	H+8	-
5	prc39	prc(i): Fast corrections (-2048 to +2047) for the prn in slot i (i = 39-50).	Long	4	H+12	-
6	prc40		Long	4	H+16	-
7	prc41		Long	4	H+20	-
8	prc42		Long	4	H+24	-
9	prc43		Long	4	H+28	-
10	prc44		Long	4	H+32	-
11	prc45		Long	4	H+36	-
12	prc46		Long	4	H+40	-
13	prc47		Long	4	H+44	-
14	prc48		Long	4	H+48	-
15	prc49		Long	4	H+52	-
16	prc50		Long	4	H+56	-
17	prc51 (Invalid, do not use)		Long	4	H+60	-
18	udrei39	udre(i): User differential range error indicator for the prn in slot i (i = 39-50).	Ulong	4	H+64	See Table 90
19	udrei40		Ulong	4	H+68	
20	udrei41		Ulong	4	H+72	
21	udrei42		Ulong	4	H+76	
22	udrei43		Ulong	4	H+80	
23	udrei44		Ulong	4	H+84	
24	udrei45		Ulong	4	H+88	
25	udrei46		Ulong	4	H+92	
26	udrei47		Ulong	4	H+96	
27	udrei48		Ulong	4	H+100	
28	udrei49		Ulong	4	H+104	
29	udrei50		Ulong	4	H+108	
30	udrei51 (Invalid, do not use)		Ulong	4	H+112	
31	xxxx	32-bit CRC (ASCII and Binary only)	Hex	4	H+116	-
32	[CR][LF]	Sentence terminator (ASCII only)	-	-	-	-

Recommended Input:

log WAAS5 onchanged

ASCII Example:

```
#WAAS5A, COM1, 0, 72.5, SATTIME, 1093, 161480.000, 00040020, 31d4, 209; 122, 1, 3,  
-7, 2047, 2047, 2047, -4, 2047, 2047, 2047, 9, 2047, 2047, -3, -2, 11, 14, 14, 14, 4, 14, 14, 14,  
5, 14, 14, 4, 2*2bf0109b
```

3.4.101 WAAS6 Integrity Message SBAS

WAAS6 is the integrity information message. Each message includes an IODF for each fast corrections message. The s^2_{UDRE} information for each block of satellites applies to the fast corrections with the corresponding IODF.

Message ID: 304
Log Type: Asynch

Field #	Field type	Data Description	Format	Binary Bytes	Binary Offset	Scaling
1	header	Log header		H	0	-
2	prn	Source PRN of message	Ulong	4	H	-
3	iodf2	Issue of fast corrections data	Ulong	4	H+4	-
4	iodf3	Issue of fast corrections data	Ulong	4	H+8	-
5	iodf4	Issue of fast corrections data	Ulong	4	H+12	-
6	iodf5	Issue of fast corrections data	Ulong	4	H+16	-
7	udrei0	udre(i): User differential range error indicator for the prn in slot i (i = 0-50)	Ulong	4	H+20	See Table 90 on Page 320
8	udrei1		Ulong	4	H+24	
9	udrei2		Ulong	4	H+28	
10	udrei3		Ulong	4	H+32	
11	udrei4		Ulong	4	H+36	
12	udrei5		Ulong	4	H+40	
13	udrei6		Ulong	4	H+44	
14	udrei7		Ulong	4	H+48	
15	udrei8		Ulong	4	H+52	
16	udrei9		Ulong	4	H+56	
17	udrei10		Ulong	4	H+60	
18	udrei11		Ulong	4	H+64	
19	udrei12		Ulong	4	H+68	
20	udrei13		Ulong	4	H+72	
21	udrei14		Ulong	4	H+76	
22	udrei15		Ulong	4	H+80	
23	udrei16		Ulong	4	H+84	
24	udrei17		Ulong	4	H+88	
25	udrei18		Ulong	4	H+92	
26	udrei19		Ulong	4	H+96	
27	udrei20		Ulong	4	H+100	
28	udrei21		Ulong	4	H+104	
29	udrei22		Ulong	4	H+108	
30	udrei23		Ulong	4	H+112	
31	udrei24		Ulong	4	H+116	

Continued on Page 328

3.4.102 WAAS7 Fast Correction Degradation SBAS

The WAAS7 message specifies the applicable IODP, system latency time and fast degradation factor indicator for computing the degradation of fast and long-term corrections.

Message ID: 305

Log Type: Asynch

Field #	Field type	Data Description	Format	Binary Bytes	Binary Offset
1	header	Log header		H	0
2	prn	Source PRN of message	Ulong	4	H
3	latency	System latency	Ulong	4	H+4
4	iodp	Issue of PRN mask data	Ulong	4	H+8
5	spare bits	Unused spare bits	Ulong	4	H+12
6	aI(0)	aI(i): Degradation factor indicator for the prn in slot i (i = 0-50)	Ulong	4	H+16
7	aI(1)		Ulong	4	H+20
8	aI(2)		Ulong	4	H+24
9	aI(3)		Ulong	4	H+28
10	aI(4)		Ulong	4	H+32
11	aI(5)		Ulong	4	H+36
12	aI(6)		Ulong	4	H+40
13	aI(7)		Ulong	4	H+44
14	aI(8)		Ulong	4	H+48
15	aI(9)		Ulong	4	H+52
16	aI(10)		Ulong	4	H+56
17	aI(11)		Ulong	4	H+60
18	aI(12)		Ulong	4	H+64
19	aI(13)		Ulong	4	H+68
20	aI(14)		Ulong	4	H+72
21	aI(15)		Ulong	4	H+76
22	aI(16)		Ulong	4	H+80
23	aI(17)		Ulong	4	H+84
24	aI(18)		Ulong	4	H+88
25	aI(19)		Ulong	4	H+92
26	aI(20)		Ulong	4	H+96
27	aI(21)		Ulong	4	H+100
28	aI(22)		Ulong	4	H+104
29	aI(23)		Ulong	4	H+108
30	aI(24)		Ulong	4	H+112
31	aI(25)		Ulong	4	H+116
32	aI(26)		Ulong	4	H+120

Continued on Page 330

33	aI(27)		Ulong	4	H+124
34	aI(28)		Ulong	4	H+128
35	aI(29)		Ulong	4	H+132
36	aI(30)		Ulong	4	H+136
37	aI(31)		Ulong	4	H+140
38	aI(32)		Ulong	4	H+144
39	aI(33)		Ulong	4	H+148
40	aI(34)		Ulong	4	H+152
41	aI(35)		Ulong	4	H+156
42	aI(36)		Ulong	4	H+160
43	aI(37)		Ulong	4	H+164
44	aI(38)		Ulong	4	H+168
45	aI(39)		Ulong	4	H+172
46	aI(40)		Ulong	4	H+176
47	aI(41)		Ulong	4	H+180
48	aI(42)		Ulong	4	H+184
49	aI(43)		Ulong	4	H+188
50	aI(44)		Ulong	4	H+192
51	aI(45)		Ulong	4	H+196
52	aI(46)		Ulong	4	H+200
53	aI(47)		Ulong	4	H+204
54	aI(48)		Ulong	4	H+208
55	aI(49)		Ulong	4	H+212
56	aI(50)		Ulong	4	H+216
57	aI(51) (Invalid, do not use)		Ulong	4	H+220
58	xxxx	32-bit CRC (ASCII and Binary only)	Hex	4	H+224
59	[CR][LF]	Sentence terminator (ASCII only)	-	-	-

Recommended Input:

log WAAS7 unchanged

ASCII Example:

```
#WAAS7A, COM1, 0, 68.0, SATTIME, 1263, 312741.000, 00000000, 12e3, 1522;
122, 1, 1, 0, 15, 15, 15, 15, 15, 15, 15, 15, 15, 15, 15, 15, 15, 15, 15, 15, 15,
15, 15, 15, 15, 15, 15, 15, 15, 15, 15, 15, 15, 15, 15, 15, 0, 0, 0, 0, 0, 0, 0,
0, 0, 0, 0, 0, 0, 0, 0, 0, 0, 0*30ef462c
```

3.4.103 WAAS9 GEO Navigation Message SBAS

WAAS9 provides the GEO navigation message representing the position, velocity and acceleration of the geostationary satellite, in ECEF coordinates and its apparent clock time and frequency offsets.

Also included is the time of applicability, an issue of data (IOD) and an accuracy exponent (URA) representing the estimated accuracy of the message. The time offset and time drift are with respect to SBAS Network Time. Their combined effect is added to the estimate of the satellite's transmit time.

Message ID: 306

Log Type: Asynch

Field #	Field type	Data Description	Format	Binary Bytes	Binary Offset
1	header	Log header		H	0
2	prn	Source PRN of message.	Ulong	4	H
3	iodn	Issue of GEO navigation data.	Ulong	4	H+4
4	t ₀	Time of applicability	Ulong	4	H+8
5	ura	URA value	Ulong	4	H+12
6	x	ECEF x coordinate	Double	8	H+16
7	y	ECEF y coordinate	Double	8	H+24
8	z	ECEF z coordinate	Double	8	H+32
9	xvel	X rate of change	Double	8	H+40
10	yvel	Y rate of change	Double	8	H+48
11	zvel	Z rate of change	Double	8	H+56
12	xaccel	X rate of rate change	Double	8	H+64
13	yaccel	Y rate of rate change	Double	8	H+72
14	zaccel	Z rate of rate change	Double	8	H+80
15	a _{f0}	Time offset	Double	8	H+88
16	a _{f1}	Time drift	Double	8	H+96
17	xxxx	32-bit CRC (ASCII and Binary only)	Hex	4	H+104
18	[CR][LF]	Sentence terminator (ASCII only)	-	-	-

Recommended Input:

log WAAS9 onchanged

ASCII Example:

```
#WAAS9A, COM1, 0, 66.5, SATTIME, 1263, 312921.000, 00000000, b580, 1522;
134, 63, 53568, 7, -42150577.2800, 1435825.6000, 3206.0000,
0.668750000, 1.490625000, -1.3800000, 0.0000500, -0.0000875,
0.000000000, 1.084990799e-07, -2.000888344e-11* b88e3009
```

3.4.104 WAAS10 Degradation Factor SBAS

The fast corrections, long-term corrections and ionospheric corrections are all provided in the WAAS10 message.

Message ID: 292

Log Type: Asynch

Field #	Field type	Data Description	Format	Binary Bytes	Binary Offset	Scaling
1	header	Log header		H	0	-
2	prn	Source PRN of message.	Ulong	4	H	-
3	b _{rcc}	Estimated noise and round off error parameter.	Ulong	4	H+4	0.002
4	c _{lrc_ls}	Maximum round off due to the lest significant bit (lsb) of the orbital clock.	Ulong	4	H+8	0.002
5	c _{lrc_vl}	Velocity error bound.	Ulong	4	H+12	0.00005
6	i _{lrc_vl}	Update interval for v=1 long term.	Ulong	4	H+16	-
7	c _{lrc_v0}	Bound on update delta.	Ulong	4	H+20	0.002
8	i _{lrc_v1}	Minimum update interval v = 0.	Ulong	4	H+24	-
9	c _{geo_ls}	Maximum round off due to the lsb of the orbital clock.	Ulong	4	H+28	0.0005
10	c _{geo_v}	Velocity error bound.	Ulong	4	H+32	0.00005
11	i _{geo}	Update interval for GEO navigation message.	Ulong	4	H+36	-
12	c _{er}	Degradation parameter.	Ulong	4	H+40	0.5
13	c _{iono_step}	Bound on ionospheric grid delay difference.	Ulong	4	H+44	0.001
14	i _{iono}	Minimum ionospheric update interval.	Ulong	4	H+48	-
15	c _{iono_ramp}	Rate of ionospheric corrections change.	Ulong	4	H+52	0.000005
16	rss _{udre}	User differential range error flag.	Ulong	4	H+56	-
17	rss _{iono}	Root sum square flag.	Ulong	4	H+60	-
18	spare bits	Spare 88 bits, possibly GLONASS.	Ulong	4	H+64	-
19	xxxx	32-bit CRC (ASCII and Binary only)	Hex	4	H+68	-
20	[CR][LF]	Sentence terminator (ASCII only)	-	-	-	-

Recommended Input:

log WAAS10 onchanged

ASCII Example:

```
#WAAS10A,COM1,0,71.5,SATTIME,1263,313009.000,00000000,c305,1522;
122,54,38,76,256,152,100,311,83,256,6,0,300,292,
0,1,000000000000000000000000*ca464fd2
```

3.4.105 WAAS12 SBAS Network Time and UTC SBAS

WAAS12 consists of the 8-bit preamble, a 6-bit message type identifier (= 12) followed by 104 information bits for the UTC parameters, then followed by 3 bits to indicate the UTC time standard from which the offset is determined.

The UTC parameters will correlate UTC time with the SBAS network time rather than with GPS time.

Message ID: 293

Log Type: Asynch

Field #	Field type	Data Description	Format	Binary Bytes	Binary Offset
1	header	Log header		H	0
2	prn	Source PRN of message	Ulong	4	H
3	A ₁	Time offset	Double	8	H+4
4	A ₀	Time drift	Double	8	H+12
5	seconds	Seconds into the week	Ulong	4	H+20
6	week	Week number	Ushort	4	H+24
7	dt _{1s}	Delta time due to leap seconds	Short	2	H+28
8	wn _{1sf}	Week number, leap second future	Ushort	2	H+30
9	dn	Day of the week (the range is 1 to 7 where Sunday = 1 and Saturday = 7)	Ushort	2	H+32
10	dt _{1sf}	Delta time, leap second future.	Short	2	H+34
11	utc id	UTC type identifier.	Ushort	2	H+36
12	gpstow	GPS time of the week.	Ulong	2	H+38
13	gpswn	GPS de-modulo week number	Ulong	2	H+40
14	glo indicator	Is GLONASS information present? 0 = FALSE 1 = TRUE	Enum	4	H+42
15	Reserved		Char[10]	12 ^a	H+46
16	xxxx	32-bit CRC (ASCII and Binary only)	Hex	4	H+58
17	[CR][LF]	Sentence terminator (ASCII only)	-	-	-

- a. In the binary log case an additional 2 bytes of padding are added to maintain 4 byte alignment

Recommended Input:

log WAAS12 unchanged

ASCII Example:

Not available at time of print.

3.4.106 WAAS17 GEO Almanac Message SBAS

Almanacs for all GEOs will be broadcast periodically to alert you of their existence, location, the general service provided, status, and health.

☒ Unused almanacs will have a PRN number of 0 and should be ignored, see *Example* below.

Message ID: 294
Log Type: Asynch

Field #	Field type	Data Description	Format	Binary Bytes	Binary Offset	Scaling
1	header	Log header		H	0	-
2	prn	Source PRN of message.	Ulong	4	H	-
3	#ents	Number of almanac entries with information to follow.	Ulong	4	H+4	-
4	data id	Data ID type	Ushort	2	H+8	-
5	entry prn	PRN for this entry	Ushort	2	H+10	-
6	health	Health bits	Ushort	4 ^a	H+12	-
7	x	ECEF x coordinate	Long	4	H+16	-
8	y	ECEF y coordinate	Long	4	H+20	-
9	z	ECEF z coordinate	Long	4	H+24	-
10	x vel	X rate of change	Long	4	H+28	-
11	y vel	Y rate of change	Long	4	H+32	-
12	z vel	Z rate of change	Long	4	H+36	-
13...	Next entry = H+8 + (#ents x 32)					-
variable	t0	Time of day in seconds (0 to 86336)	Ulong	4	H+8+ (#ents x 32)	64
variable	xxxx	32-bit CRC (ASCII and Binary only)	Hex	4	H+12+ (#ents x 32)	-
variable	[CR][LF]	Sentence terminator (ASCII only)	-	-	-	-

a. In the binary log case an additional 2 bytes of padding is added to maintain 4 byte alignment

Recommended Input:

log WAAS17 onchanged

ASCII Example:

```
#WAAS17A,COM1,0,68.5,SATTIME,1263,312890.000,00000000,896c,1522;
122,3
,0,134,0,-42151200,1435200,0,0,0,0,
0,122,0,24788400,-34091200,-26000,0,0,0,
0,0,0,0,0,0,0,0,53568*82d6f8cb
```

3.4.108 WAAS24 Mixed Fast/Slow Corrections SBAS

If there are 6 or fewer satellites in a block, they may be placed in this mixed correction message. The fast data set for each satellite consists of 16 bits; a 12-bit fast correction and a 4-bit UDRE indicator. Each message also contains a 2-bit IODP indicating the associated PRN mask.

The 12-bit fast correction (PRC) has a 0.125 meter resolution, for a valid range of -256 to +255.875 m. If the range is exceeded a don't use indication will be inserted into the UDREI field. You should ignore extra data sets not represented in the PRN mask.

The time of applicability (T0) of the PRC is the start of the epoch of the WAAS Network Time (WNT) second that is coincident with the transmission at the GEO satellite of the first bit of the message block.

Message ID: 297

Log Type: Asynch

Field #	Field type	Data Description	Format	Binary Bytes	Binary Offset	Scaling
1	header	Log header		H	0	-
2	prn	Source PRN of message.	Ulong	4	H	-
3	prc0	prc(i):	Long	4	H+4	-
4	prc1	Fast corrections (-2048 to +2047) for the prn in slot i (i = 0-5).	Long	4	H+8	-
5	prc2		Long	4	H+12	-
6	prc3		Long	4	H+16	-
7	prc4		Long	4	H+20	-
8	prc5		Long	4	H+24	-
9	udrei0		udre(i):	Ulong	4	H+28
10	udrei1	User differential range error indicator for the prn in slot i (i = 0-5).	Ulong	4	H+.32	
11	udrei2		Ulong	4	H+36	
12	udrei3		Ulong	4	H+40	
13	udrei4		Ulong	4	H+44	
14	udrei5		Ulong	4	H+48	
15	iodp		Issue of PRN mask data.	Ulong	4	H+52
16	block id	Associated message type.	Ulong	4	H+56	
17	iodf	Issue of fast corrections data.	Ulong	4	H+60	-
18	spare	Spare value.	Ulong	4	H+64	-
19	vel	Velocity code flag.	Ulong	4	H+68	-
20	mask1	Index into PRN mask (Type 1).	Ulong	4	H+72	-
21	iode1	Issue of ephemeris data.	Ulong	4	H+76	-
22	dx1	Delta x (ECEF).	Long	4	H+80	0.125
23	dy1	Delta y (ECEF).	Long	4	H+84	0.125
24	dz1	Delta z (ECEF).	Long	4	H+88	0.125
25	da ^{f0}	Delta a ^{f0} clock offset.	Long	4	H+92	2 ⁻³¹
26	mask2	Second index into PRN mask (Type 1).	Ulong	4	H+96	-
27	iode2	Second issue of ephemeris data.	Ulong	4	H+100	-
28	ddx	Delta delta x (ECEF).	Long	4	H+104	2 ⁻¹¹

Continued on Page 337

29	ddy	Delta delta y (ECEF).	Long	4	H+108	2^{-11}
30	ddz	Delta delta z (ECEF).	Long	4	H+112	2^{-11}
31	da ^{f1}	Delta a ^{f1} clock offset.	Long	4	H+116	2^{-39}
32	t ₀	Applicable time of day.	Ulong	4	H+120	16
33	iodp	Issue of PRN mask data.	Ulong	4	H+124	-
34	corr spare	Spare value when velocity code = 0.	Ulong	4	H+128	-
35	xxxx	32-bit CRC (ASCII and Binary only)	Hex	4	H+132	-
36	[CR][LF]	Sentence terminator (ASCII only)	-	-	H+136	-

Recommended Input:

log WAAS24 unchanged

ASCII Example:

```
#WAAS24A, COM1, 0, 66.0, SATTIME, 1263, 313608.000, 00000100, 0a33, 1522;
122, 0, 2047, -1, 2047, 14, 0, 5, 14, 12, 14, 10, 13, 1, 2, 1, 0, 1, 0, 0, 0, 0, 0,
0, 0, 0, 0, 0, 0, 0, 0, 0*cb977f29
```

3.4.109 WAAS25 Long-Term Slow Satellite Corrections SBAS

WAAS25 provides error estimates for slow varying satellite ephemeris and clock errors with respect to WGS-84 ECEF coordinates.

Message ID: 298

Log Type: Asynch

Field #	Field type	Data Description	Format	Binary Bytes	Binary Offset	Scaling
1	header	Log header		H	0	-
2	prn	Source PRN of message	Ulong	4	H	-
3	vel	Velocity code flag (0 or 1)	Ulong	4	H+4	-
4	mask1	Index into PRN mask (Type 1)	Ulong	4	H+8	-
5	iode1	Issue of ephemeris data	Ulong	4	H+12	-
6	dx1	Delta x (ECEF)	Long	4	H+16	0.125
7	dy1	Delta y (ECEF)	Long	4	H+20	0.125
8	dz1	Delta z (ECEF)	Long	4	H+24	0.125
9	a ^{f0}	Delta a ^{f0} clock offset	Long	4	H+28	2 ⁻³¹
10	mask2	Second index into PRN mask (Type 1) Dummy value when velocity code = 1	Ulong	4	H+32	-
11	iode2	Second issue of ephemeris data Dummy value when velocity code = 1	Ulong	4	H+36	-
12	ddx	Delta delta x (ECEF) when velocity code = 1 Delta x (dx) when velocity code = 0	Long	4	H+40	2 ⁻¹¹
13	ddy	Delta delta y (ECEF) when velocity code = 1 Delta y (dy) when velocity code = 0	Long	4	H+44	2 ⁻¹¹
14	ddz	Delta delta z (ECEF) when velocity code = 1 Delta z (dz) when velocity code = 0	Long	4	H+48	2 ⁻¹¹
15	a ^{f1}	Delta a ^{f1} clock offset when velocity code = 1 Delta a ^{f0} clock offset when velocity code = 0	Long	4	H+52	2 ⁻³⁹
16	t ₀	Applicable time of day Dummy value when velocity code = 0	Ulong	4	H+56	16
17	iodp	Issue of PRN mask data	Ulong	4	H+60	-
18	corr spare	Spare value when velocity code = 0 Dummy value when velocity code = 1	Ulong	4	H+64	-
19	vel	Velocity code flag (0 or 1)	Ulong	4	H+68	-
20	mask1	Index into PRN mask (Type 1)	Ulong	4	H+72	-
21	iode1	Issue of ephemeris data	Ulong	4	H+76	-
22	dx1	Delta x (ECEF)	Long	4	H+80	0.125
23	dy1	Delta y (ECEF)	Long	4	H+84	0.125
24	dz1	Delta z (ECEF)	Long	4	H+88	0.125

Continued on Page 339

25	a ^{f0}	Delta a ^{f0} clock offset	Long	4	H+92	2 ⁻³¹
26	mask2	Second index into PRN mask (Type 1) Dummy value when velocity code = 1	Ulong	4	H+96	-
27	iode2	Second issue of ephemeris data Dummy value when velocity code = 1	Ulong	4	H+100	-
28	ddx	Delta delta x (ECEF) when velocity code = 1 Delta x (dx) when velocity code = 0	Long	4	H+104	2 ⁻¹¹
29	ddy	Delta delta y (ECEF) when velocity code = 1 Delta y (dy) when velocity code = 0	Long	4	H+108	2 ⁻¹¹
30	ddz	Delta delta z (ECEF) when velocity code = 1 Delta z (dz) when velocity code = 0	Long	4	H+112	2 ⁻¹¹
31	a ^{f1}	Delta a ^{f1} clock offset when velocity code = 1 Delta a ^{f0} clock offset when velocity code = 0	Long	4	H+116	2 ⁻³⁹
32	t ₀	Applicable time of day Dummy value when velocity code = 0	Ulong	4	H+120	16
33	iodp	Issue of PRN mask data	Ulong	4	H+124	-
34	corr spare	Spare value when velocity code = 0 Dummy value when velocity code = 1	Ulong	4	H+128	-
35	xxxx	32-bit CRC (ASCII and Binary only)	Hex	4	H+132	-
36	[CR][LF]	Sentence terminator (ASCII only)	-	-	H+136	-

Recommended Input:

log WAAS25 onchanged

ASCII Example:

```
#WAAS25A, COM1, 0, 57.0, SATTIME, 1263, 313767.000, 00000100, b8ff, 1522;
122, 1, 5, 188, -13, 9, -14, -16, 0, 0, -1, 0, 2, 2, 3401, 1, 0, 1, 19, 142, 15, -35,
-14, 14, 0, 0, 0, 0, 1, 0, 3401, 1, 0*693f7091
```

3.4.110 WAAS26 Ionospheric Delay Corrections SBAS

WAAS26 provides vertical delays (relative to an L1 signal) and their accuracy at geographically defined IGP's identified by the BAND NUMBER and IGP number. Each message contains a band number and a block ID, which indicates the location of the IGP's in the respective band mask.

Message ID: 299

Log Type: Asynch

Field #	Field type	Data Description	Format	Binary Bytes	Binary Offset	Scaling
1	header	Log header		H	0	-
2	prn	Source PRN of message	Ulong	4	H	-
3	band num	Band number	Ulong	4	H+4	-
4	block id	Block ID	Ulong	4	H+8	-
5	#pts	Number of grid points with information to follow	Ulong	4	H+12	-
6	igp _{vde}	IGP vertical delay estimates	Ulong	4	H+16	0.125
7	givei	Grid ionospheric vertical error indicator	Ulong	4	H+20	-
8...	Next #pts entry = H + 16 + (#pts x 8)					
variable	iodi	Issue of data - ionosphere	Ulong	4	H+16+ (#pts x 8)	
variable	spare	7 spare bits	Ulong	4	H+20+ (#pts x 8)	-
variable	xxxx	32-bit CRC (ASCII and Binary only)	Hex	4	H+24+ (#pts x 8)	-
variable	[CR][LF]	Sentence terminator (ASCII only)	-	-	-	-

Recommended Input:

log WAAS26 onchanged

ASCII Example:

```
#WAAS26A,COM1,0,68.0,SATTIME,1263,313875.000,00000100,ec70,1522;
122,1,3,15,13,11,29,13,25,13,25,12,22,11,19,11,17,11,16,11,13,
12,13,13,32,13,30,13,26,12,23,11,21,11,2,0*b214a093
```

3.4.111 WAAS27 SBAS Service Message SBAS

WAAS27 messages apply only to the service provider transmitting the message. The number of service messages indicates the total number of unique WAAS27 messages for the current IODS. Each unique message for that IODS includes a sequential message number. The IODS increments in all messages, each time that any parameter in any WAAS27 message is changed.

Message ID: 300

Log Type: Asynch

Field #	Field type	Data Description	Format	Binary Bytes	Binary Offset	Scaling
1	header	Log header		H	0	-
2	prn	Source PRN of message	Ulong	4	H	-
3	iods	Issue of slow corrections data	Ulong	4	H+4	-
4	#messages	Low-by-one count of messages	Ulong	4	H+8	-
5	message num	Low-by-one message number	Ulong	4	H+12	-
6	priority code	Priority code	Ulong	4	H+16	-
7	dudre inside	Delta user differential range error - inside	Ulong	4	H+20	-
8	dudre outside	Delta user differential range error - outside	Ulong	4	H+24	-
9...	#reg	Number of regions with information to follow	Ulong	4	H+28	-
variable	lat1	Coordinate 1 latitude	Long	4	H+32	-
variable	lon1	Coordinate 1 longitude	Long	4	H+36	-
variable	lat2	Coordinate 2 latitude	Long	4	H+40	-
variable	lon2	Coordinate 2 longitude	Long	4	H+44	-
variable	shape	Shape where: 0 = triangle 1 = square	Ulong	4	H+48	-
variable	Next #reg entry = H + 32 + (#reg x 20)					
variable	t ₀	Time of applicability	Ulong	4	H+32+ (#reg x 20)	16
variable	xxxx	32-bit CRC (ASCII and Binary only)	Hex	4	H+36+ (#reg x 20)	-
variable	[CR][LF]	Sentence terminator (ASCII only)	-	-	-	-

Recommended Input:

log WAAS27 unchanged

ASCII Example:

Not available at time of print.

3.4.112 WAAS32 CDGPS Fast Correction Slots 0-10 CDGPS

WAAS32 are fast corrections for slots 0-10 in the mask of WAAS1 for CDGPS, see *Page 318*.

Message ID: 696

Log Type: Asynch

Field #	Field type	Data Description	Format	Binary Bytes	Binary Offset	Scaling
1	header	Log header		H	0	
2	prn	Source PRN of message.	Ulong	4	H	-
3	iodp	Issue of PRN mask data.	Ulong	4	H+4	-
4	prc0	prc(i): Fast corrections (-2048 to +2047) for the prn in slot i (i = 0-10).	Long	4	H+8	-
5	prc1		Long	4	H+12	-
6	prc2		Long	4	H+16	-
7	prc3		Long	4	H+20	-
8	prc4		Long	4	H+24	-
9	prc5		Long	4	H+28	-
10	prc6		Long	4	H+32	-
11	prc7		Long	4	H+36	-
12	prc8		Long	4	H+40	-
13	prc9		Long	4	H+44	-
14	prc10		Long	4	H+48	-
15	udre0	udre(i): User differential range error indicator for the prn in slot i (i = 0-10).	Ulong	4	H+52	See <i>Table 91, Evaluation of CDGPS UDREI on Page 343</i>
16	udre1		Ulong	4	H+56	
17	udre2		Ulong	4	H+60	
18	udre3		Ulong	4	H+64	
19	udre4		Ulong	4	H+68	
20	udre5		Ulong	4	H+72	
21	udre6		Ulong	4	H+76	
22	udre7		Ulong	4	H+80	
23	udre8		Ulong	4	H+84	
24	udre9		Ulong	4	H+88	
25	udre10		Ulong	4	H+92	
26	xxxx	32-bit CRC (ASCII and Binary only)	Hex	4	H+96	-
27	[CR][LF]	Sentence terminator (ASCII only)	-	-	-	-

Recommended Input:

log WAAS32 unchanged

ASCII Example:

```
#WAAS32A,COM2,0,70.5,FINE,1295,153284.000,00000240,18e9,34461;209,0,0,
-8097,0,0,0,0,-947,0,-2128,0,2570,14,0,14,14,14,14,0,14,0,14,0*58778ae5
```

Table 91: Evaluation of CDGPS UDREI

UDREI	UDRE meters
0	0.01
1	0.02
2	0.03
3	0.05
4	0.10
5	0.15
6	0.20
7	0.25
8	0.30
9	0.35
10	0.40
11	0.45
12	0.50
13	0.60
14	Not Monitored
15	Do Not Use

3.4.113 WAAS33 CDGPS Fast Correction Slots 11-21 CDGPS

WAAS33 are fast corrections for slots 11-21 in the mask for CDGPS.

Message ID: 697

Log Type: Asynch

Field #	Field type	Data Description	Format	Binary Bytes	Binary Offset	Scaling
1	header	Log header		H	0	
2	prn	Source PRN of message.	Ulong	4	H	-
3	iodp	Issue of PRN mask data.	Ulong	4	H+4	-
4	prc11	prc(i): Fast corrections (-2048 to +2047) for the prn in slot i (i = 11-21).	Long	4	H+8	-
5	prc12		Long	4	H+12	-
6	prc13		Long	4	H+16	-
7	prc14		Long	4	H+20	-
8	prc15		Long	4	H+24	-
9	prc16		Long	4	H+28	-
10	prc17		Long	4	H+32	-
11	prc18		Long	4	H+36	-
12	prc19		Long	4	H+40	-
13	prc20		Long	4	H+44	-
14	prc21		Long	4	H+48	-
15	udre11	udre(i): User differential range error indicator for the prn in slot i (i = 11-21).	Ulong	4	H+52	See Table 91, Evaluation of CDGPS UDREI on Page 343
16	udre12		Ulong	4	H+56	
17	udre13		Ulong	4	H+60	
18	udre14		Ulong	4	H+64	
19	udre15		Ulong	4	H+68	
20	udre16		Ulong	4	H+72	
21	udre17		Ulong	4	H+76	
22	udre18		Ulong	4	H+80	
23	udre19		Ulong	4	H+84	
24	udre20		Ulong	4	H+88	
25	udre21		Ulong	4	H+92	
26	xxxx	32-bit CRC (ASCII and Binary only)	Hex	4	H+96	-
27	[CR][LF]	Sentence terminator (ASCII only)	-	-	-	-

Recommended Input:

log WAAS33 unchanged

ASCII Example:

```
#WAAS33A,COM2,0,47.5,FINE,1295,158666.000,01000240,b23e,34461;209,0,0,
-3343,0,0,0,-533,0,0,0,0,0,14,0,14,14,14,0,14,14,14,14,14*6d890E5f
```

3.4.114 WAAS34 CDGPS Fast Correction Slots 22-32 CDGPS

WAAS34 are fast corrections for slots 22-32 in the mask of WAAS1 for CDGPS, see *Page 318*.

Message ID: 698

Log Type: Asynch

Field #	Field type	Data Description	Format	Binary Bytes	Binary Offset	Scaling	
1	header	Log header		H	0		
2	prn	Source PRN of message.	Ulong	4	H	-	
3	iodp	Issue of PRN mask data.	Ulong	4	H+4	-	
4	prc22	prc(i): Fast corrections (-2048 to +2047) for the prn in slot i (i = 22-32).	Long	4	H+8	-	
5	prc23		Long	4	H+12	-	
6	prc24		Long	4	H+16	-	
7	prc25		Long	4	H+20	-	
8	prc26		Long	4	H+24	-	
9	prc27		Long	4	H+28	-	
10	prc28		Long	4	H+32	-	
11	prc29		Long	4	H+36	-	
12	prc30		Long	4	H+40	-	
13	prc31		Long	4	H+44	-	
14	prc32		Long	4	H+48	-	
15	udrei22		udre(i): User differential range error indicator for the prn in slot i (i = 22-32).	Ulong	4	H+52	See Table 91, Evaluation of CDGPS UDREI on Page 343
16	udrei23			Ulong	4	H+56	
17	udrei24			Ulong	4	H+60	
18	udrei25	Ulong		4	H+64		
19	udrei26	Ulong		4	H+68		
20	udrei27	Ulong		4	H+72		
21	udrei28	Ulong		4	H+76		
22	udrei29	Ulong		4	H+80		
23	udrei30	Ulong		4	H+84		
24	udrei31	Ulong		4	H+88		
25	udrei32	Ulong		4	H+92		
26	xxxx	32-bit CRC (ASCII and Binary only)		Hex	4	H+96	
27	[CR][LF]	Sentence terminator (ASCII only)	-	-	-	-	

Recommended Input:

log WAAS34 onchanged

ASCII Example:

```
#WAAS34A,COM2,0,73.0,FINE,1295,226542.000,00000040,1be8,34461;209,0,5879,0,0,0,0,2687,0,10922,10922,10922,10922,0,14,14,14,14,0,14,15,15,15,15*3aeb74be
```

3.4.115 WAAS35 CDGPS Fast Correction Slots 33-43 CDGPS

WAAS35 are fast corrections for slots 33-43 in the mask of WAAS1 for CDGPS, see *Page 318*.

Message ID: 699

Log Type: Asynch

Field #	Field type	Data Description	Format	Binary Bytes	Binary Offset	Scaling
1	header	Log header		H	0	
2	prn	Source PRN of message.	Ulong	4	H	-
3	iodp	Issue of PRN mask data.	Ulong	4	H+4	-
4	prc33	prc(i): Fast corrections (-2048 to +2047) for the prn in slot i (i = 33-43).	Long	4	H+8	-
5	prc34		Long	4	H+12	-
6	prc35		Long	4	H+16	-
7	prc36		Long	4	H+20	-
8	prc37		Long	4	H+24	-
9	prc38		Long	4	H+28	-
10	prc39		Long	4	H+32	-
11	prc40		Long	4	H+36	-
12	prc41		Long	4	H+40	-
13	prc42		Long	4	H+44	-
14	prc43		Long	4	H+48	-
15	udrei33	udre(i): User differential range error indicator for the prn in slot i (i = 33-43).	Ulong	4	H+52	See <i>Table 91, Evaluation of CDGPS UDREI on Page 343</i>
16	udrei34		Ulong	4	H+56	
17	udrei35		Ulong	4	H+60	
18	udrei36		Ulong	4	H+64	
19	udrei37		Ulong	4	H+68	
20	udrei38		Ulong	4	H+72	
21	udrei39		Ulong	4	H+76	
22	udrei40		Ulong	4	H+80	
23	udrei41		Ulong	4	H+84	
24	udrei42		Ulong	4	H+88	
25	udrei43		Ulong	4	H+92	
26	xxxx	32-bit CRC (ASCII and Binary only)	Hex	4	H+96	-
27	[CR][LF]	Sentence terminator (ASCII only)	-	-	-	-

Recommended Input:

log WAAS35 onchanged

ASCII Example:

This message is not being broadcast by CDGPS at the time of publication.

3.4.116 WAAS45 CDGPS Slow Corrections CDGPS

Each WAAS45 message contains a 2-bit IODP indicating the associated PRN mask.

The time of applicability (T0) of the PRC is the start of the epoch of the WAAS Network Time (WNT) second that is coincident with the transmission at the CDGPS satellite (PRN 209) of the first bit of the message block.

Message ID: 700
Log Type: Asynch

Field #	Field type	Data Description	Format	Binary Bytes	Binary Offset	Scaling
1	header	Log header		H	0	-
2	prn	Source PRN of message	Ulong	4	H	-
3	mask1	Index into PRN mask (Type 1)	Ulong	4	H+4	-
4	iode1	Issue of ephemeris data	Ulong	4	H+8	-
5	dx1	Delta x (ECEF)	Long	4	H+12	0.125
6	dy1	Delta y (ECEF)	Long	4	H+16	0.125
7	dz1	Delta z (ECEF)	Long	4	H+20	0.125
8	ddx	Delta delta x (ECEF)	Long	4	H+24	2 ⁻¹¹
9	ddy	Delta delta y (ECEF)	Long	4	H+28	2 ⁻¹¹
10	ddz	Delta delta z (ECEF)	Long	4	H+32	2 ⁻¹¹
11	da ^{f0} 1	Delta a ^{f0} clock offset	Long	4	H+36	2 ⁻³¹
12	t01	Applicable time of day	Ulong	4	H+40	16
13	mask2	Second index into PRN mask (Type 1)	Ulong	4	H+44	-
14	iode2	Second issue of ephemeris data	Ulong	4	H+48	-
15	dx1	Delta x (ECEF)	Long	4	H+52	0.125
16	dy1	Delta y (ECEF)	Long	4	H+56	0.125
17	dz1	Delta z (ECEF)	Long	4	H+60	0.125
18	ddx	Delta delta x (ECEF)	Long	4	H+64	2 ⁻¹¹
19	ddy	Delta delta y (ECEF)	Long	4	H+68	2 ⁻¹¹
20	ddz	Delta delta z (ECEF)	Long	4	H+72	2 ⁻¹¹
21	da ^{f0} 2	Delta a ^{f0} clock offset	Long	4	H+76	2 ⁻³¹
22	t02	Applicable time of day	Ulong	4	H+80	16
23	iodp	Issue of PRN mask data	Ulong	4	H+84	-
24	xxxx	32-bit CRC (ASCII and Binary only)	Hex	4	H+88	-
25	[CR][LF]	Sentence terminator (ASCII only)	-	-	-	-

Recommended Input:

log WAAS45 unchanged

ASCII Example:

```
#WAAS45A,COM2,0,73.0,FINE,1295,228498.000,00000040,c730,34461;209,23,32,197,
-116,206,-1,-6,-3,-5546,3488,25,148,262,-312,867,4,3,0,2513,3488,0*02d6e0d5
```

3.4.117 WAASCORR SBAS Range Corrections Used SBAS

The information is updated with each pseudorange position calculation. It will have an entry for each tracked satellite. Satellites that are not included in an SBAS corrected solution will have 0.0 in both the 'psr corr' and 'corr stdv' fields.

The 'psr corr' is the combined fast and slow corrections and is to be added to the pseudorange. Ionospheric and tropospheric corrections are not included and should be applied separately.

Message ID: 313

Log Type: Synch

Field #	Field type	Data Description	Format	Binary Bytes	Binary Offset
1	header	Log header		H	0
2	#sat	Number of satellites with information to follow	Ulong	4	H
3	prn	Satellite PRN	Ulong	4	H+4
4	iode	Issue of ephemeris data for which the corrections apply	Ulong	4	H+8
5	psr corr	SBAS pseudorange correction (m)	Float	4	H+12
6	corr stdv	Standard deviation of pseudorange correction (m)	Float	4	H+16
7...	Next sat entry = H+4 + (#sat x 16)				
variable	xxxx	32-bit CRC (ASCII and Binary only)	Hex	4	H+4+ (#sat x 16)
variable	[CR][LF]	Sentence terminator (ASCII only)	-	-	-

Recommended Input:

log waascorr ontime 1

ASCII Example:

```
#WAASCORRA, COM1, 0, 60.0, FINESTBEERING, 1263, 313990.000, 00000100, 3b3b, 1522;
18,
28, 188, 0.0000, 0.0000, 28, 0, 0.0000, 0.0000,
20, 142, 0.0000, 0.0000, 20, 0, 0.0000, 0.0000,
4, 43, 0.0000, 0.0000, 4, 0, 0.0000, 0.0000,
24, 65, 0.0000, 0.0000, 24, 0, 0.0000, 0.0000,
7, 172, 0.0000, 0.0000, 7, 0, 0.0000, 0.0000,
9, 99, 0.0000, 0.0000, 9, 0, 0.0000, 0.0000,
14, 115, 0.0000, 0.0000, 14, 0, 0.0000, 0.0000,
5, 188, 0.0000, 0.0000, 5, 0, 0.0000, 0.0000,
122, 0, 0.0000, 0.0000, 134, 0, 0.0000, 0.0000*ee39c730
```

The receiver is capable of outputting several responses for various conditions. Most of these responses are error messages to indicate when something is not correct.

The output format of the messages is dependant on the format of the input command. If the command is input as abbreviated ASCII, the output will be abbreviated ASCII. Likewise for ASCII and binary formats. *Table 92* outlines the various responses.

Table 92: Response Messages

ASCII Message	Binary Message ID	Meaning
OK	1	Command was received correctly.
REQUESTED LOG DOES NOT EXIST	2	The log requested does not exist.
NOT ENOUGH RESOURCES IN SYSTEM	3	The request has exceeded a limit (for example, the maximum number of logs are being generated).
DATA PACKET DOESN'T VERIFY	4	Data packet is not verified
COMMAND FAILED ON RECEIVER	5	Command did not succeed in accomplishing requested task.
INVALID MESSAGE ID	6	The input message ID is not valid.
INVALID MESSAGE. FIELD = X	7	Field <i>x</i> of the input message is not correct.
INVALID CHECKSUM	8	The checksum of the input message is not correct. This only applies to ASCII and binary format messages.
MESSAGE MISSING FIELD	9	A field is missing from the input message.
ARRAY SIZE FOR FIELD X EXCEEDS MAX	10	Field <i>x</i> contains more array elements than allowed.
PARAMETER X IS OUT OF RANGE	11	Field <i>x</i> of the input message is outside the acceptable limits.
TRIGGER X NOT VALID FOR THIS LOG	14	Trigger type <i>x</i> is not valid for this type of log.
AUTHCODE TABLE FULL - RELOAD SOFTWARE	15	Too many authcodes are stored in the receiver. The receiver firmware must be reloaded.
INVALID DATE FORMAT	16	This error is related to the inputting of authcodes. It indicates that the date attached to the code is not valid.
INVALID AUTHCODE ENTERED	17	The authcode entered is not valid.
NO MATCHING MODEL TO REMOVE	18	The model requested for removal does not exist.
NOT VALID AUTH CODE FOR THAT MODEL	19	The model attached to the authcode is not valid.
CHANNEL IS INVALID	20	The selected log cannot be output at the specified rate.

Continued on Page 350

REQUESTED RATE IS INVALID	21	The requested rate is invalid.
WORD HAS NO MASK FOR THIS TYPE	22	The word has no mask for this type of log.
CHANNELS LOCKED DUE TO ERROR	23	Channels are locked due to error.
INJECTED TIME INVALID	24	Injected time is invalid
COM PORT NOT SUPPORTED	25	The COM or USB port is not supported.
MESSAGE IS INCORRECT	26	The message is invalid.
INVALID PRN	27	The PRN is invalid.
PRN NOT LOCKED OUT	28	The PRN is not locked out.
PRN LOCKOUT LIST IS FULL	29	PRN lock out list is full.
PRN ALREADY LOCKED OUT	30	The PRN is already locked out.
MESSAGE TIMED OUT	31	Message timed out.
UNKNOWN COM PORT REQUESTED	33	Unknown COM or USB port requested.
HEX STRING NOT FORMATTED CORRECTLY	34	Hex string not formatted correctly.
INVALID BAUD RATE	35	The baud rate is invalid.
MESSAGE IS INVALID FOR THIS MODEL	36	This message is invalid for this model of receiver.
COMMAND ONLY VALID IF IN NVM FAIL MODE	40	Command is only valid if NVM is in fail mode
INVALID OFFSET	41	The offset is invalid.
MAXIMUM NUMBER OF USER MESSAGES REACHED	78	Maximum number of user messages has been reached.
GPS PRECISE TIME IS ALREADY KNOWN	84	GPS precise time is already known.

Index

1PPS, *see* one pulse per second
2-D, 78, 196
3-D, 78, 196, 230

A

abbreviated ascii, 13, 16
absolute coordinates, 107
accumulated Doppler range (ADR), 236, 241
accuracy
 correction, 77
 degradation, 161
 limit, 101
 position, 77, 107-108
 RTK solution, 141
 time, 22
acquisition, 47, 77, 127, 239
active model, 97
ADJUST1PPS, 42
ADR, *see* accumulated Doppler range
age
 differential
 RTK, 141-142, 291, 293
 velocity, 166, 168, 232, 235, 296
 xyz coordinates, 168, 235, 296
 solution
 at mark input, 214
 ECEF coordinates, 168, 235, 296
 OmniSTAR HP, 224
 position, 161, 231
 RTK, 291
 UTM coordinates, 164
air dynamic, 72
alignment, 13, 42, 239, 245
ALMANAC, 157
almanac
 complete, 307
 data, 186
 GEO, 334
 log, 143-144, 157
 lost, 99
 minimum time to collect, 186

raw data, 243
reference time, 186
reset, 83
stored, 83
time status, 21
along track, 221-222
altitude
 and vertical speed, 166, 232, 293
 error, 197
 fix-related, 188, 190, 192
 high, 73, 138
ambiguity
 half cycle, 236
 L1 pseudorange, 280, 284
 resolution speed, 107
 type, 112, 288, 290
anomaly, 157, 312
antenna
 active, 46
 altitude, 73, 138, 188, 190, 192
 baseline, 107
 current, 299
 height, 287
 motion, 48-49, 110, 234
 phase center, 79
 position, 214
 power, 126
 receiver status, 300
 reference point (ARP), 286-287
 speed, 222
ANTENNAPOWER, 46
anti-spoofing (AS), 157
approximate position, 121
ARP, *see* antenna reference point
AS, *see* anti-spoofing
ascii
 message, 14, 27, 264
 overview, 14
 printable data, 118
 redirect, 226
 response, 20
 send, 118
 text message, 125

- ASSIGN, 47
- assign
 - all channels, 49
 - cancel, 127
 - channel, 29, 47
 - cut-off angle, 73, 138
- ASSIGNALL, 49
- ASSIGNLBAND, 51
- ASSIGNOMNI, 51
- asterisk, 14
- asynchronous log, 23, 139
- atmospheric
 - delay, 236
 - refraction, 73, 138
- AUTH, 53
- authorization, 27, 53-54
- AUX, 60
- AUX port, 19, 60
- auxiliary status, 126, 300-301, 303-306
- AVEPOS, 159
- averaging, position, 30, 101, 159
- azimuth, 198, 307

- B**
- band pull-in, 239
- bandwidth, 56-57, 114, 175
- base station
 - antenna reference point (ARP), 286-287
 - carrier-to-noise ratio, 280, 284
 - command, 29
 - ECEF coordinates, 286-287
 - health, 250, 261
 - log, 143
 - moving, 98
 - position, 250, 257
 - send data, 119
- baseline
 - command, 107-108
 - ECEF coordinates, 171
 - estimate, 98
 - float solution, 288
 - initial, 107
 - length, 111
 - moving base station, 98
 - RTK, 28, 143-144, 171
 - static, 30
- battery, 178, 182
- baud rate, *see* bps
- bearing, 93-94, 199, 221-222
- best solution available, 161
- BESTPOS, 161
- BESTUTM, 164
- BESTVEL, 164
- BESTXYZ, 168
- bias, 55, 143
- bi-directional communication, 226
- binary
 - only port, 88
 - overview, 16
 - raw ephemeris, 244
 - redirect, 226
 - response, 20
- bit rate, *see* bps
- board
 - component type, 315
 - internal oscillator, 76
 - temperature, 299
- boot
 - file, 157, 243
 - up, 106, 186
 - version, 314, 316
- bps, 59, 99, 185, 228
- break, 59, 62, 88, 185, 228
- broadcast almanac, 186
- BSLNXYZ, 171
- buffer, 90, 290
- Bursa-Wolf transformation, 133
- byte, 14, 17

- C**
- C/A code
 - GPS quality indicator, 188-193
 - L2 code indicator, 282, 284
 - type, 237, 277-284
- C/N0, *see* carrier to noise density ratio
- carrier phase, 55, 177, 234-238, 242, 255
- carrier to noise density ratio (C/N0), 198, 209, 238, 241-242, 311
- CDGPS, 51, 207-210
 - assign, 51
 - fast corrections, 342-346
 - NMEA, 195
 - prn mask, 318
 - raw frame data, 247

- slow corrections, 347
- type, 105, 162
- channel
 - assign, 47-48
 - control, 29, 144
 - idle, 126
 - range measurements, 236
 - raw subframe data, 245, 249
 - tracking status, 237, 239, 241, 311
 - unassign, 127
- character message, 264
- checksum, 14, 16
- clock
 - adjustment, 42, 55, 236
 - aging, 157, 201-202
 - bias, 55, 180
 - command, 31
 - dither, 74, 173
 - drift, 55, 175
 - error, 48-49, 55, 173
 - internal, 22
 - model, 74, 173-174
 - offset, 73, 144, 180, 216, 230, 309
 - parameters, 74
 - phase, 42
 - receiver, 309
 - set, 236
 - source, 176
 - status, 143, 173, 216, 309
 - steer, 55-56, 175-176
 - type, 75
 - validity, 173
- CLOCKADJUST, 55
- CLOCKCALIBRATE, 56
- CLOCKMODEL, 171
- CLOCKOFFSET, 58
- CLOCKSTEERING, 175
- CMR, 88, 105, 177, 251
- CMRDATADESC, 178
- CMRDATAOBS, 180
- CMRDATAREF, 182, 184
- CMRPLUS, 184
- COM, 59
- COM port, 90-92, 118, 185, 228, 304
- COMCONFIG, 180
- COMCONTROL, 61
- communication command, 27
- compile date, 316
- component, 314-315
- configuration
 - non-volatile memory, 83
 - port, 27, 59, 185
 - receiver, 106, 140, 297, 300
 - reset, 38, 106
 - save, 115
 - status mask, 126
- Console window, 115
- constellation, 174, 230
- constraint, 236
- continuous tracking, 209, 238, 242, 311
- control
 - automatic, 127
 - channel, 29
 - command, 27
 - filtering, 140
 - receiver, 27, 140
- convention, 11
- convergence, 163
- coordinated universal time (UTC)
 - log, 140, 144, 205
 - of position, 188, 190, 192, 197
 - offset, 216, 309
 - status, 309
- coordinates, absolute, 107
- corrected mean motion, 157
- correction
 - accuracy, 77
 - bias, 79
 - dgps, 104
 - magnetic, 94
 - magnitude of, 93
 - RTCA, 88
 - RTK, 114
 - smoothing, 100
- correlator spacing, 237, 239
- corrupt data, 99
- covariance, 163, 173-174, 288
- CPU, 90, 228, 299
- CRC, *see* cyclic redundancy check
- cross track, 199, 221-222
- CSMOOTH, 63
- current, antenna, 299
- customer service, 11
- cut-off angle, 73, 111, 138, 230, 312
- cyclic redundancy check (CRC), 14, 16-17, 24

D

data link, 119
date, 200, 205
DATUM, 63
datum, 79
 command, 28, 63, 68, 79, 133
 current, 123
 customized, 133
 expanded, 134
 fix position, 80
 ID, 161, 164, 214, 217, 224, 231, 291
 transformation parameters, 65
 user, 133
default
 command table, 12
 factory, 28, 40, 64, 68, 106
delay
 ephemeris, 68
 reset, 106
 signal, 58
delimiter, 118
delta position, 163, 166
destination, 123, 199, 222
de-weighting, 89, 111, 230
DGPS command, 68, 70-71, 87, 197
DGPSEPHMDELAY, 68
DGPSTIMEOUT, 70
DGPSTXID, 71
differential correction
 accept, 87
 age, 161, 164
 DGPS, 70
 OmniSTAR HP, 224
 pseudorange position, 231
 RTK, 141-142, 291, 293, 296
 velocity, 166, 232, 293
 xyz coordinates, 168, 235, 296
 fix position, 77, 79
 none available, 312
 outage, 161, 231, 291, 293
 positioning, 68
 send, 101, 119
 station, 78, 104, 113, 143, 312
 transmit RTCA, 68
 type, 104
dilution of precision (DOP), 144, 188-192,
196, 230

direction
 bearing, 222
 of motion, 234
 over ground, 232
 referenced to True North, 93
distance
 along track, 222
 exceeded, 163
 navigation, 221
 straight line, 222
 track offset, 123
dither, 74, 173
divergence-free smoothing, 277
Doppler
 assign, 47-49
 instantaneous, 162, 238, 242
 jump, 55
 range record, 241
 satellite visibility, 307
 tracking status, 311
 velocity computation, 166, 234
drift, 55
drop-offs, 128
DYNAMICS, 72
dynamics, 28, 72, 110, 290

E

earth-centered earth-fixed (ECEF), 107-108,
168, 170, 250
easting, 164-165
eccentricity, 157, 186, 201
ECEF, *see* earth-centered earth-fixed
echo, 185
ECUTOFF, 73, 138
elevation, 198
 cut-off, 73, 138, 230
 error, 312
 highest, 114
 mask, 111
 NMEA, 198
 rapidly changing, 128
 RTK, 30
 satellite visibility, 307
 set, 28
 tracking status, 311
ellipsoid
 customized, 133

- height, 107-108
- navigation, 123
- parameters, 64-65, 134
- surface, 123
- undulation, 29, 128
- embedded message, 297
- encryption, L2, 255
- environmental parameter, 72, 299
- ephemeris
 - decoded, 144
 - delay, 68, 70
 - health, 312
 - log, 144
 - old, 312
 - raw data, 144, 244, 254
 - reset, 83
 - time status, 21-22
- error
 - averaged position, 101
 - checking, 77
 - clock, 55, 74, 173
 - extrapolation, 217, 219
 - flag, 300
 - framing, 228
 - in fixed coordinates, 79
 - multipath, 236
 - non-volatile memory, 99
 - oscillator, 173
 - parity, 228
 - range reject code, 312
 - receiver, 300, 302, 305
 - response message, 349
 - status, 126
 - text description, 305
 - tracking, 236
 - trigger, 300
 - word, 306
- event
 - message, 126, 300, 305
 - text description, 305
 - trigger, 300
 - type, 305-306
- expiry, 97, 313
- export restriction, 163, 302
- external
 - oscillator, 74
 - reference frequency, 42, 55
- EXTERNALCLOCK, 74
- extrapolation error, 217, 219
- F**
- factory default
 - datum, 64
 - ephemeris delay, 68
 - modify, 115
 - reset, 28, 38, 106
 - setting, 40, 59
- field type, 13
- filter
 - control, 28
 - error, 312
 - pseudorange, 311
 - RTK, 28, 109
 - solution, 140
 - update, 234, 295
- fine time, 22
- firmware, 2, 12, 53, 302, 314-315
- FIX, 77
- fix
 - command, 77
 - data, 188, 190, 192
 - position, 194
 - save setting, 115
 - solution, 28, 30, 109
- fixed integer ambiguities, 112
- FIXPOSDATUM, 80
- flag
 - antenna, 46
 - parity, 236
 - status, 231, 300
- flags
 - error, 300
- flattening, 134
- float solution, 28, 30, 109
- floating point ambiguities, 112
- foot dynamic, 72
- format, 14, 16, 24
- framing error, 228
- free wheeling, 22
- frequency, external reference, 42, 55
- FREQUENCYOUT, 81
- FRESET, 83-84
- G**
- Gauss-Markov process, 173

general purpose analog input (GPAI), 299
geodetic datum, *see* datum
geoid, 29, 78, 128, 159, 188-192
geostationary satellite, 331, 334
global navigation satellite system (GNSS),
265-266, 269-270, 277-284
GNSS, *see* global navigation satellite
system
GPAI, *see* general purpose analog input
GPGGA, 190
GPGGALONG, 190
GPGGARTK, 188
GPGLL, 194
GPGRS, 195
GPGSA, 196
GPGST, 197
GPGSV, 198
GPRMB, 199
GPRMC, 200
GPS, 121
GPS overview, 22-23
GPS+ Reference Manual, 78, 121, 157, 293
GPSEPHEM, 201
GPSolution, 115
GPVTG, 204
GPZDA, 205
great circle line, 123, 222
grid point, 128, 335, 340
grouping, 237, 239

H

half cycle, ambiguity, 236-237
handshaking, 60, 185
hardware
 overrun, 228
 parameter, 299
 platform, 316
 reset, 28, 106
 version, 140, 314
harmonic coefficients, 93
HDOP, *see* dilution of precision
header
 ascii, 14-15, 20
 binary, 13, 20
 convention, 12
 log, 236
health

almanac, 186
base station, 143, 250, 261
satellite, 157, 307-308, 312
status, 201
height
 antenna, 287
 approximate, 121
 baseline, 108
 calculation, 78
 ellipsoidal, 108
 fix, 28, 77-78
 limit, 163
 mark, 214
 mean sea level, 107-108
 OmniSTAR HP, 85, 224
 position, 159-161, 217, 231, 291
 UTM, 164-165

Helmert transformation, 133
hexadecimal, 12-14, 17, 20, 120, 126
hold, 90-92, 212-213
horizon, cut-off angle, 73, 138
HP, OmniSTAR, 113, 224
HPSEED, 85
HPSTATICINIT, 86

I

identifier
 ascii message, 14
 serial port, 18, 87, 185, 228
idle
 channel, 47-50, 126, 300
 L1/L2, 239
 time, 15, 17, 90
IGP, *see* ionospheric grid point
IGRF, *see* international geomagnetic
reference field
IMU, *see* inertial measurement unit
inclination angle, 157, 186, 201
inertial
 measurement unit (IMU), 88, 315
 navigation system (INS), 161-163
initialization, 107
input pulse, 214, 216
insufficient
 observations, 163
 resources error, 139
interface, 27, 30, 87

- INTERFACEMODE, 87
 - international geomagnetic reference field (IGRF), 93
 - interrupt, 228
 - IOD, *see* issue of data
 - IOD, *see* issue of ephemeris data
 - ionospheric
 - corrections, 258, 263, 308, 332
 - delay, 263, 332, 335, 340
 - free, 162, 290
 - grid point (IGP), 335
 - log, 140, 144-145, 206
 - none available, 312
 - parameter, 206
 - rate, 263
 - severe, 290
 - update, 332
 - IONUTC, 206
 - issue of
 - data (IOD), 260, 262, 331
 - ephemeris data (IODE)
 - CDGPS, 347
 - GPS, 201
 - invalid, 312
 - RTCA, 253
 - RTCM, 269-270
 - SBAS, 336-339, 348
- K**
- Kalman filter, 162
 - knots, 199-200, 204
- L**
- land dynamic, 72
 - lane combination, 288
 - latched time, 214
 - latency
 - best position, 161
 - data link, 217, 219
 - position, 141, 295
 - velocity, 142, 166, 168, 234-235, 295-296
 - latitude/longitude
 - approximate, 121
 - fix data, 188, 190, 192
 - GPS specific, 200
 - mark, 214
 - NMEA, 194
 - OmniSTAR HP, 85, 224
 - position, 161, 217, 231, 291
 - RTK baseline, 108
 - set navigation waypoints, 123
 - sign, 107
 - L-Band, 83, 104, 207-209
 - LBANDINFO, 207
 - LBANDSTAT, 209
 - leading edge triggered, 95
 - leap second, 206
 - limit, 163, 165, 302
 - line feed, 14, 118, 120
 - link
 - data, 119
 - indicators, 228
 - LNA, *see* low noise amplifier
 - local
 - horizon, 73, 138
 - zone, 205
 - lock
 - command, 89
 - frequency, 82
 - indicator, 277-278, 282, 284
 - L1/L2, 255
 - out, 89, 230, 312
 - phase, 82
 - reinstate, 130
 - time, 63, 209, 238, 241-242, 311
 - LOCKOUT, 89
 - LOG, 90
 - log
 - list, 212
 - remove, 131-132
 - trigger, 139
 - type, 139
 - LOGLIST, 212
 - low noise amplifier (LNA), 27, 46, 299
 - LSB, 14
- M**
- magnetic variation, 29, 93-94, 200, 222
 - MAGVAR, 93
 - mark event, 23, 95, 140, 214, 216
 - MARKCONTROL, 95
 - MARKPOS, 214
 - MARKTIME, 216
 - mask

- angle, 28, 111, 169, 219
 - priority, 126, 300-301
 - RTK, 30, 164
 - set/clear, 126, 300
 - matched update, 288
 - MATCHEDPOS, 217
 - matrix, 173
 - mean anomaly, 186, 201
 - mean sea level
 - fix, 78, 188, 190, 192
 - mark, 214
 - OmniSTAR HP, 85, 224
 - position, 161, 217, 231, 291
 - RTK baseline, 107-108
 - UTM, 164
 - measurement smoothing, 100
 - memory, 178, 182
 - buffer space, 90
 - DRAM status, 302
 - non-volatile
 - almanac, 157, 243
 - clock calibrate, 56
 - erase, 38, 83
 - save configuration, 33, 115
 - restore, 99
 - meridian, UTM, 135
 - message
 - almanac, 157
 - ascii, 14
 - base station, 250
 - embedded, 297
 - format, 13, 16, 24
 - ID, 17, 212-213
 - length, 125
 - multiple, 198
 - navigation, 123
 - number, 198
 - responses, 20
 - send, 118
 - string, 125
 - time stamp, 23
 - trigger, 91-92
 - misclosure, 312
 - mode
 - 2-D, 196
 - 3-D, 196
 - dynamic, 110
 - interface, 87
 - operating, 196
 - RTK, 107, 161
 - static, 110
 - MODEL, 97
 - model
 - authorization, 27, 53-54, 97
 - card, 97
 - clock, 173-174, 216
 - expiry date, 140, 313
 - ionospheric, 206
 - log, 140
 - lost, 99
 - reset, 83
 - switch, 97
 - version, 313-314
 - modem, 87, 226
 - month, 309, 316
 - motion
 - detector, 110
 - dynamic, 110
 - mean, 157, 202
 - mountain, 128
 - moving, 72, 98, 166
 - MOVINGBASESTATION, 98
 - MSB, 14
 - multipath, 236
 - multiple base stations, 104
- ## N
- Narrow Correlator tracking technology, 239
 - narrow-lane ambiguity, 162, 290
 - nautical mile, 199
 - NAVIGATE, 221
 - navigation
 - command, 29
 - data, 196, 200
 - information, 199
 - log, 221
 - magnetic compass, 93
 - path, 123-124
 - status, 199, 222
 - waypoint, 123, 141
 - word, 246
 - NMEA, 140, 142-144, 192-197
 - node, 186
 - noise
 - oscillator, 74

- statistic, 197
 - thermal, 236
 - time of, 174
 - non-printable character, 27, 120
 - non-volatile memory (NVM), 38
 - almanac, 157, 243
 - current configuration, 115
 - reset, 83
 - restore, 99
 - nothing, 164-165
 - note
 - antenna motion, 110
 - authorization code, 53
 - channel assignment, 47, 49
 - clock adjustment, 55
 - differential corrections, 68, 70
 - elevation cut-off angle, 73
 - ephemeris delay, 68
 - factory default, 99
 - logging, 90
 - navigation, 221
 - range residual, 195
 - reset, 38, 83
 - RTK, 107, 109
 - satellite, 230
 - status, 300, 305
 - WGS84, 159
 - NovAtel Inc., 2
 - NVMRESTORE, 85, 98
- O**
- observation
 - base station, 141, 161, 177-180, 252, 255
 - buffered, 141
 - good, 312
 - insufficient, 162-163
 - L1 only, 242, 277, 280
 - L1/L2, 282, 284
 - local, 141
 - matched, 171, 217, 288
 - number tracked, 238
 - RTK, 111
 - two lines, L1 and L2, 238
 - offset
 - clock, 73-74, 144, 216, 230, 309
 - Doppler, 47
 - log, 92
 - track, 123, 222
 - OMNIHPPPOS, 224
 - OMNIINFO, 207
 - OmniSTAR, 52, 105, 162, 248
 - OMNISTAT, 209
 - one pulse per second (1PPS)
 - adjust, 42
 - clock command, 31
 - coherency, 81-82
 - control, 103
 - delay, 58
 - error, 309
 - offset, 55
 - time, 310
 - with synchronous log, 23
 - operating mode, 196
 - optionality, 12
 - origin, 123
 - oscillator, 55-56, 74-76, 173, 175
 - outage, 161, 231, 278, 291-293
 - output pulse, 81
 - overload, 90
- P**
- P code
 - alignment, 239
 - code type, 237, 277, 280, 282, 284
 - flag, 180, 265-266, 269-270
 - L2 code indicator, 282, 284
 - parity
 - almanac, 157
 - error, 228
 - known flag, 236-237, 239
 - navigation word, 246
 - port, 185, 228
 - removed, 244
 - subframe data, 245
 - type, 60
 - parsing data, 14, 236, 311
 - PASSAUX, 226
 - PASSCOMx, 226
 - pass-through log, 87, 226
 - PASSTOPASSMODE, 100
 - PASSUSBx, 226
 - PDOP, *see* dilution of precision
 - pending, 163
 - perigee, 157, 186, 201

- period, 90-92, 103, 175, 212-213
 - perpendicular distance, 123, 222
 - persistence, UTM, 135
 - phase lock loop (PLL), 239, 302
 - PLL, *see* phase lock loop
 - polarity, 95-96, 103
 - polled log, 23, 139
 - port
 - ascii header, 15
 - AUX, 18-19, 60-62
 - COM, 18, 59-60, 90-92, 118, 304
 - communication, 16
 - configuration, 27, 59, 185
 - disable, 87
 - number of interrupts, 228
 - output, 90, 92, 212-213
 - pass-through, 226
 - receiver status, 300
 - save configuration, 115
 - serial, 87-88, 228
 - statistic, 140
 - status, 228, 305
 - unlog, 132
 - PORTSTATS, 228
 - position
 - 3-D, 230
 - accuracy, 77, 107, 182-183
 - approximate, 121
 - at time of mark, 214
 - averaging, 30, 101, 159-160
 - base station, 98, 143, 250, 257
 - best, 161, 164, 168, 288
 - command, 28
 - current, 221-222
 - datum, 64
 - delta, 163
 - fix, 28, 79
 - log, 140-141
 - matched, 217, 219
 - pseudorange, 143, 231
 - single point, 162
 - solution, 73, 230
 - time out, 102
 - type, 214
 - validity, 163
 - xyz coordinates, 168, 219, 234, 295
 - POSTIMEOUT, 102
 - power, 46, 312
 - PPSCONTROL, 103
 - precision, 13, 21, 188-194, 196, 200
 - prerequisites, 11
 - printable data, 118
 - PRN
 - almanac, 186
 - assign, 47-50
 - lock out, 89, 237, 350
 - multiple observables, 236, 311
 - SBAS, 317-318
 - specific, 116
 - unlock, 130
 - processing, 15, 17, 144, 236
 - pseudorange, 266
 - correction, 78, 253, 274
 - DOP, 230
 - error, 236, 267, 272
 - filter, 311
 - integrity, 312
 - jump, 55, 236
 - L1, 180, 277, 280, 282, 284
 - L2-L1 difference, 282, 284
 - measurement, 197, 238, 241-242
 - minimum, 255, 274
 - noise statistic, 197
 - offset, 255
 - position, 142-143, 195, 231, 234
 - rate correction, 253
 - residual, 311
 - SBAS, 348
 - scale, 260, 262, 270
 - smoothing, 277
 - solution, 78, 161
 - tracking status, 311
 - velocity, 143, 166, 232, 234
 - PSRDIFFSOURCE, 104
 - PSRPOS, 231
 - PSRVEL, 232
 - PSRXYZ, 234
 - Pulse Aperture Correlator (PAC), 239
 - pulse, mark input, 214, 216
 - pulsewidth, 175
- ## Q
- quality, 84, 188, 190, 192, 197
 - quotation mark, 14, 118, 125

R

RANGE, 236

range

- bias, 22, 173-174
- compressed, 240
- L1/L2 in computation, 161
- log, 236
- measurement, 55
- reject code, 311
- residual, 195
- satellite information, 89

RANGECMP, 240

RANGEGPSL1, 242

rate of right ascension, 157, 186, 201

raw almanac, 186

RAWALM, 242

RAWEPHEM, 244

RAWGPSSUBFRAME, 245

RAWGPSWORD, 246

RAWLBANDFRAME, 247

RAWLBANDPACKET, 248

RAWOMNIFRAME, 247

RAWOMNIPACKET, 248

RAWWAASFRAME, 249

reacquisition, 47, 49, 72, 239

reboot, 186

receiver

- character, 228
- interface, 27, 30, 87
- status, 90, 300, 303

reference

- or standard, 157, 243
- point, 221
- station, *see* base station

REFSTATION, 250

reinstate satellite, 130

remote station, *see* rover station

RESET, 106

reset

- average positions after, 101
- complete, 109
- hardware, 28, 83, 106
- RTK, 109

residual, 163, 195, 288, 311

resolution, 107, 109

response, 20, 87, 349

restore, 99

RF delay, 58

RMS, *see* root mean square

root mean square (RMS), 197

rover station command, 30

RTCA, 68, 70, 87-88, 105, 251-252

RTCADATA1, 253

RTCADATAAEPHEM, 254

RTCADATAAOBS, 255

RTCADATAREF, 257

RTCM, 68, 88, 105, 251, 258-275

RTCMDATA1, 260

RTCMDATA1001, 277

RTCMDATA1002, 280

RTCMDATA1003, 282

RTCMDATA1004, 284

RTCMDATA1005, 286

RTCMDATA1006, 287

RTCMDATA15, 263

RTCMDATA16, 264

RTCMDATA1819, 265

RTCMDATA2021, 269

RTCMDATA3, 261

RTCMDATA59, 274

RTCMDATA9, 262

RTCMV3, 71, 88, 105, 251, 276-287

RTK

baseline, 28, 30, 107, 144

command, 30

convention, 11

corrections, 114

data, 143, 288

dynamic, 290

filter, 109

low latency position, 141, 291

mode, 161, 295

observations, 111

position, 141, 161, 217, 219, 291

processing, 112

satellite count, 144

solution, 112, 288

velocity, 293

RTKBASELINE, 107

RTKCOMMAND, 109

RTKDATA, 273

RTKDYNAMICS, 110

RTKELEV MASK, 111

RTKPOS, 291

RTKSOLUTION, 112

RTKSOURCE, 113
RTKSVENTRIES, 114
RTKVEL, 293
RTKXYZ, 295
RXCONFIG, 297
RXHWLEVELS, 299
RXSTATUS, 300
RXSTATUSEVENT, 305

S

satellite

- acquisition, 47, 121
- active, 196
- almanac, 157
- available, 78
- clock, 74, 308
- command, 29
- common, 288
- coordinates, 308
- count, 143-144
- elevation cut-off, 73, 138
- error, 312
- geometry, 230
- geostationary, 331
- GLONASS slot #, 238, 242, 307, 311
- in use, 190
- in view, 198
- lock, 89, 230
- number of, 230, 240
- PRN, 238, 242
- range, 195
- raw, 243-246
- reinstate, 130
- RTK, 30, 111, 114, 288
- system indicator, 286-287
- tracking, 144, 236, 311
- type, 263
- unassign, 127
- unlock, 130
- visibility, 144, 307

SATVIS, 307
SATXYZ, 308
SAVECONFIG, 115
SBAS, 249, 317-341, 348

- channels, 47, 50
- control, 116
- degradation factor, 329, 332

- dgps type, 105
- differential, 104
- ephemeris, 348
- fast corrections, 319-330, 336
- frame data, 249
- GEO navigation message, 331
- integrity, 327
- ionospheric grid, 340
- position, 162
- prn, 48-49
- pseudorange, 348
- service provider, 341
- simulator, 116
- slow corrections, 336, 338
- system type, 117
- time, 331, 333
- UTC, 333

SBASCONTROL, 116

scaling

- almanac, 157
- factor, 241

scope, 11

searcher status and type, 290

seed position, OmniSTAR HP, 85

self-test, 90

semi-major axis, 133-134, 157, 186, 197, 201

SEND, 118

send, 118, 120

SENDHEX, 120

sequence, 15, 17, 21

serial port, 87-88, 185, 228

SETAPPROXPOS, 121

SETAPPROXTIME, 122

SETNAV, 121

setting, command, 26, 115, 297

signal delay, 58

single point position, 162

singularity, 163

smoothing, 100, 268, 277-280, 284

software version, 140

solution

- computed, 163
- L1 ambiguity, 162
- narrow-lane/wide-lane, 162
- pseudorange differential, 162
- smoothing, 100
- status, 77, 214

source of data, 71

specific correction type, 116

speed

current, 222

data, 141, 200

dynamic, 72

NMEA, 200, 204

of light, 173

over ground, 142, 166, 232, 293

vertical, 166, 293

SPS, *see* standard positioning service

standard positioning service (SPS), 157, 243

standards and references, 157, 243

static mode, 86, 110, 178, 217-219, 290

station ID, 71, 250

stationary HP receiver, 86

status

arrival, 199

auxiliary, 126, 300-301, 303-306

base station health, 250

channel tracking, 237-238, 241-242, 311

clock model, 216, 309

COM port, 228

command, 27

data, 194

event, 305

flag, 231, 300

indicator, 161, 166-168, 234, 295

L-Band, 209

mask, 126

receiver, 15-17, 90, 140, 300, 303

self-test, 140

solution, 77, 214

time, 15

tracking, 311

velocity, 168, 293

word, 305-306

STATUSCONFIG, 126

steep drop-off, 128

steer

clock, 55-56, 175-176

direction, 199

L1/L2, 239

time, 21-22

tracking loop, 72

subframe, 23, 144, 157, 243-245

subscription, OmniSTAR, 207-208

supply voltage, 299

synchronize, 45, 310

synchronous log, 23, 139

T

testmode, SBAS, 116-117

TIME, 308

time

almanac reference, 243

anomaly, 157

approximate, 122

arrival, 45, 222

clock adjustment, 55

coarse/fine, 21

CPU, 90

current, 23

data, 309

delay, 68

dilution of precision, 230

ephemeris, 68, 244

fine, 22

GNSS, 265

GPS, 23, 173, 309

idle, 15, 17

improve acquisition, 77

interval, 91-92, 234

latched, 214

limit, 101

log, 143, 309

mark event, 216

matched position, 143, 219

out, 70, 102

position fix, 194

precision, 21

stamp, 23, 219, 246

standard, 75

status, 15, 17, 21-22, 310

steering, 21, 55

synchronization, 42, 310

tag, 139, 166, 234, 250, 295

to first fix (TTFF), 121

UTC, 188, 190, 192, 194, 205, 309

validity, 21

TIMESYNC, 310

top bit, 17

track

made good, 200, 204

over ground, 166, 232, 293

tracking

assign, 47
 automatic, 127
 channel, 236, 311
 continuous, 209, 238, 242, 311
 cut-off angle, 73
 fix position, 79
 loop, 236
 satellite, 29, 144, 230
 status, 209-210, 237-238, 241-242, 311
 undesirable, 89
TRACKSTAT, 311
 tractor, 72
 transformation parameter, 64
 transmit, 27, 30, 59, 87, 228
 trigger

- asynchronous, 90
- error, 300
- event message, 126
- log, 90, 139, 212-213, 217-219
- option, 92

 tropospheric, 308
 true north, 93-94, 166, 197, 222, 232, 293
 tunnel, serial port, 88
 type, field, 13

U

UDRE, *see* user differential range error
UNASSIGN, 127
UNASSIGNALL, 127
 underwater canyon, 128
UNDULATION, 128
 undulation

- best position, 161, 164, 224
- command, 107, 128
- height, 107
- illustration, 129
- NMEA, 188, 190
- position, 159, 214, 217, 231, 291
- type, 85

 universal time coordinated (UTC), 206, 216, 309, 333
UNLOCKOUT, 130
UNLOCKOUTALL, 130
UNLOG, 131
UNLOGALL, 132
 USB port, 60, 118
 user differential range error (UDRE), 253,

260, 262, 319-346
USERDATUM, 133
USEREXPDATUM, 134
 UTM System, 136
 UTMZONE, 135

V

validity

- base station, 251, 295
- clock model, 173
- receiver model, 97, 313-314
- time tag, 234, 295

VALIDMODELS, 313
 variable frequency (VARF), 81
 variance, 75, 163, 202
VBS, OmniSTAR, 52, 105, 162, 207-209
VCTCXO, *see* oscillator
VDOP, *see* dilution of precision
 vehicle, 72, 142, 232, 234
 velocity

- average, 234, 295
- best, 166, 168
- closing, 199
- dynamic, 72
- latency, 234, 295-296
- limit, 163
- log, 142
- offset, 134
- pseudorange, 143, 232
- RTK, 293
- status, 234
- time tag, 293
- xyz coordinates, 134, 168, 234, 295

VERSION, 314
 version, 2, 53, 140, 314
 vessel, 142, 194, 222, 232, 234
 virtual address, 15
 visibility, satellite, 144, 307
 voltage, 299
 Volume 1

- Built-In Status Tests, 300
- Message Formats, 177, 252, 259, 276
- prerequisite, 11
- Technical Specifications, 214, 216, 305

W

WAAS network time (WNT), 336, 347

WAAS0, 317
 WAAS1, 318
 WAAS10, 332
 WAAS12, 333
 WAAS17, 334
 WAAS18, 335
 WAAS2, 319, 342
 WAAS24, 336, 347
 WAAS25, 338
 WAAS26, 340
 WAAS27, 341
 WAAS3, 321, 344
 WAAS32, 342
 WAAS33, 344
 WAAS34, 345
 WAAS35, 346
 WAAS4, 323, 345
 WAAS45, 347
 WAAS5, 325, 346
 WAAS6, 327
 WAAS7, 329
 WAAS9, 331
 WAASCORR, 348
 WAASCORRECTION, 135
 WAASECUTOFF, 138
 warning, 53
 warranty, 11
 waypoint
 destination, 199, 222
 navigation, 29, 123, 141, 199, 221
 track offset, 123
 week
 almanac, 243
 broadcast, 122
 decoding, 23
 ephemeris, 244
 future, 206
 GPS, 15, 17, 23, 122, 201, 222
 weighting, pseudorange filter, 311
 WGS84
 datum, 64, 79
 ellipsoid, 159, 168
 set waypoints, 123
 wide-lane ambiguity, 162, 290
 WNT, *see* WAAS network time
 word
 error, 99, 126
 navigation, 246

NMEA, 186
 status, 300, 305-306
 subframe, 244
 world map, 135

X

XP, OmniSTAR, 104, 162-163, 207, 209-211
 xyz coordinates, 140, 142, 168, 234, 250

Y

year, 205, 309, 316

Z

Z count, 201, 253, 260-266, 269-270, 273-274
 zone number, 135-136, 164-165



Recyclable



Printed in Canada on recycled paper