

## WARRANTY POLICY

NovAtel Inc. warrants that its Global Positioning System (GPS) products are free from defects in materials and workmanship, subject to the conditions set forth below, for the following periods of time:

GPSAntenna™ Modules	One (1) Year
Cables and Accessories	Ninety (90) Days

Date of sale shall mean the date of the invoice to the original customer for the product. NovAtel's responsibility respecting this warranty is limited solely to product repair at an authorized NovAtel location only. Determination of repair will be made by NovAtel personnel or by technical personnel expressly authorized by NovAtel for this purpose.

THE FOREGOING WARRANTIES DO NOT EXTEND TO (I) NONCONFORMITIES, DEFECTS OR ERRORS IN THE PRODUCTS DUE TO ACCIDENT, ABUSE, MISUSE OR NEGLIGENT USE OF THE PRODUCTS OR USE IN OTHER THAN A NORMAL AND CUSTOMARY MANNER, ENVIRONMENTAL CONDITIONS NOT CONFORMING TO NOVATEL'S SPECIFICATIONS, OR FAILURE TO FOLLOW PRESCRIBED INSTALLATION, OPERATING AND MAINTENANCE PROCEDURES, (II) DEFECTS, ERRORS OR NONCONFORMITIES IN THE PRODUCTS DUE TO MODIFICATIONS, ALTERATIONS, ADDITIONS OR CHANGES NOT MADE IN ACCORDANCE WITH NOVATEL'S SPECIFICATIONS OR AUTHORIZED BY NOVATEL, (III) NORMAL WEAR AND TEAR, (IV) DAMAGE CAUSED BY FORCE OF NATURE OR ACT OF ANY THIRD PERSON, (V) SHIPPING DAMAGE; OR (VI) SERVICE OR REPAIR OF PRODUCT WITHOUT PRIOR WRITTEN CONSENT FROM NOVATEL.

IN ADDITION, THE FOREGOING WARRANTIES SHALL NOT APPLY TO PRODUCTS DESIGNATED BY NOVATEL AS BETA SITE TEST SAMPLES, EXPERIMENTAL, DEVELOPMENTAL, PREPRODUCTION, SAMPLE, INCOMPLETE OR OUT OF SPECIFICATION PRODUCTS OR TO RETURNED PRODUCTS IF THE ORIGINAL IDENTIFICATION MARKS HAVE BEEN REMOVED OR ALTERED.

THE WARRANTIES AND REMEDIES ARE EXCLUSIVE AND ALL OTHER WARRANTIES, EXPRESS OR IMPLIED, WRITTEN OR ORAL, INCLUDING THE IMPLIED WARRANTIES OF MERCHANTABILITY OR FITNESS FOR ANY PARTICULAR PURPOSE ARE EXCLUDED.

NOVATEL SHALL NOT BE LIABLE FOR ANY LOSS, DAMAGE OR EXPENSE ARISING DIRECTLY OR INDIRECTLY OUT OF THE PURCHASE, INSTALLATION, OPERATION, USE OR LICENSING OF PRODUCTS OR SERVICES. IN NO EVENT SHALL NOVATEL BE LIABLE FOR SPECIAL, INDIRECT, INCIDENTAL OR CONSEQUENTIAL DAMAGES OF ANY KIND OR NATURE DUE TO ANY CAUSE.

There are no user-serviceable parts in the GPSAntenna and no maintenance is required. When the GPSCard status code indicates that the unit is faulty, replace with another unit and return the faulty unit to NovAtel Inc.

You must obtain a RETURN MATERIAL AUTHORIZATION (RMA) number by calling GPS Customer Service at 1-800-280-2242 (North America only) or 403-295-4900 before shipping any product to NovAtel or Dealer.

Once you have obtained an RMA number, you will be advised of proper shipping procedures to return any defective product. When returning any product to NovAtel, please return the defective product in the original packaging to avoid ESD and shipping damage.

© 1999 NovAtel Inc. All rights reserved  
Unpublished rights reserved under International copyright laws.  
Printed in Canada on recycled paper. Recyclable.

29 July 1999  
OM-20000017 Rev. 3  
NovAtel Inc.  
1120 – 68<sup>th</sup> Avenue N.E.  
Calgary, Alberta, Canada T2E 8S5  
<http://www.novatel.ca>



## NovAtel L1/L2 GPSAntenna™ Model 502

### - User Information -

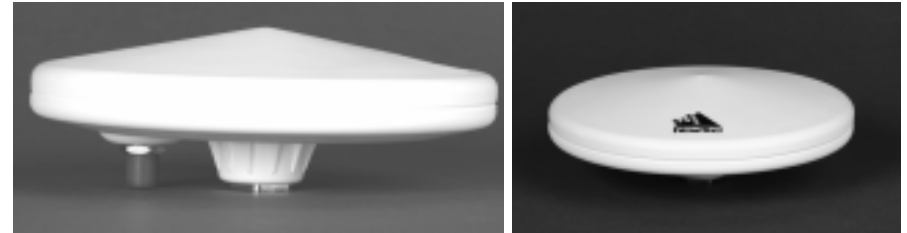

### DESCRIPTION

The Model 502 GPSAntenna is intended for surveying and other kinematic positioning applications. The sealed radome allows the antenna to be used in severe weather and hostile environments, and the unit's compact size and light weight ensure its portability.

The Model 502 GPSAntenna is an active antenna designed to operate at the GPS L1 and L2 frequencies, 1575.42 and 1227.60 MHz. The microstrip receiving elements are coupled to filters and a low-noise amplifier (LNA). The unit is optimized to receive right-hand-circularly-polarized signals, and its radiation pattern is shaped to reduce signals arriving at low elevation angles; these features decrease the errors associated with electromagnetic interference and multipath.

Both the input DC power and the output RF signal flow over a single coaxial cable that is connected to the unit's TNC female connector.

The antenna baseplate features a permanent adaptor that accepts a 5/8" x 11 threaded bolt; this allows the antenna to be used on a tripod.

△ **Caution:** overtightening a bolt into the base may damage the base.

# GPSAntenna Model 502 Technical Specifications

## - ELECTRICAL -

3 dB pass band:	L1:	1575 ± 10 MHz
	L2:	1227 ± 10 MHz
Out-of-band rejection:	$f_c \pm 50$ MHz:	25 dB (L1), 40 dB (L2)
	$f_c \pm 100$ MHz:	45 dB (L1), 60 dB (L2)
	$f_c \pm 150$ MHz:	> 65 dB (min.)
Antenna elev. pattern:	$\theta = 90^\circ$ :	+ 6.5 dBic (typical)
(90° = zenith)	$20^\circ \leq \theta < 90^\circ$ :	- 1.0 dBic to 6.0 dBic (typical)
	$5^\circ \leq \theta < 20^\circ$ :	- 3.5 dBic to 1.0 dBic (typical)
	$0^\circ \leq \theta < 5^\circ$ :	- 4.5 dBic to -0.5 dBic (typical)
	$\theta = 0^\circ$ :	- 4.5 dBic to -1.0 dBic (typical)
LNA gain:		26 ± 2 dB
Polarization:		Right-hand circular
Noise figure:		≤ 2.5 dB
L1-L2 differential propagation delay:		≤ 10.0 nsec
Axial ratio:	$\theta = 90^\circ$ :	2.0 dB max. (L2), 3.0 dB max. (L1)
(90° = zenith)	$30^\circ \leq \theta < 90^\circ$ :	2.5 dB max. (L2), 5.0 dB max. (L1)
	$15^\circ \leq \theta < 30^\circ$ :	4.0 dB max. (L2), 6.5 dB max. (L1)
	$5^\circ \leq \theta < 15^\circ$ :	6.0 dB max. (L2), 11.0 dB max. (L1)
	$0^\circ \leq \theta < 5^\circ$ :	7.0 dB max. (L2), 14.0 dB max. (L1)
Nominal impedance:		50 Ω
VSWR:		≤ 2.0:1
Power requirements:		≤ 50 mA @ + 4.25 to + 18.0 V DC
		40 mA (typical) @ 5.0 V DC
Power handling:		≤ 1 W

## - MECHANICAL & ENVIRONMENTAL -

Finish:	Weatherable polymer
Weight:	≈ 434 g
Altitude:	≤ 6096 m (20,000')
Temperature:	-40 °C to +70 °C

## Mechanical Drawings

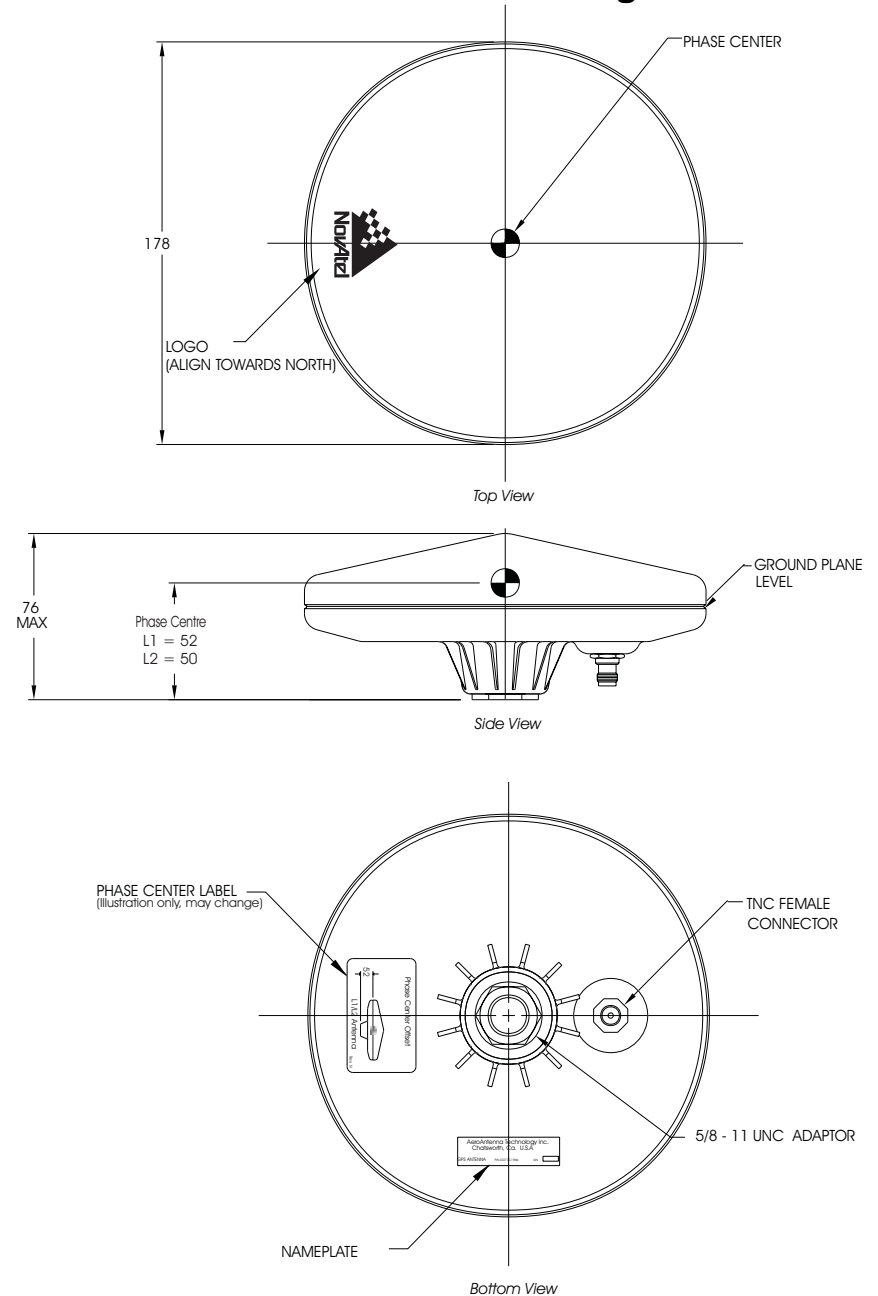

Note: All dimensions in millimetres except for thread size.